

Indiana Limestone Handbook

22nd Edition

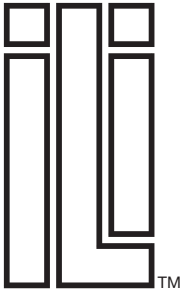

**Indiana Limestone Institute
of America, Inc.**



The Indiana Limestone Institute wishes to thank the Natural Stone Council for its generous grant, which was used to print this Handbook and to make it available for downloading from our website.

INDIANA LIMESTONE INSTITUTE OF AMERICA, INC.

STONE CITY BANK BLDG.
#400
BEDFORD, IN 47421
812-275-4426
FAX 812-279-8682
Web Page <http://www.iliai.com>

The Indiana Limestone Institute and its member companies will help users with any technical or aesthetic problem. We invite requests for assistance and will call on interested parties on request.

The publication of this Handbook is made possible in no small part by the efforts of the ILI Technical Committee which is comprised of engineers, design specialists and other interested industry personnel. The Committee meets regularly to evaluate technical inquiries regarding Indiana Limestone and to conduct an on-going review of the Handbook and other ILI publications. As a result this Handbook is supplemented from time to time with technical papers and informational brochures.

OTHER ILI LITERATURE AVAILABLE UPON REQUEST

The Finishing Touch	How To Avoid Small Area Stains and Blemishes
Preassembled Systems	Repair Booklet
Contractor's Handbook	Specification Booklet
Job-Site Folder	Case History Series
The Advantage of Indiana Limestone	

ILI Technote Series

Use and Overuse of Testing in Specifying Dimension Limestone	Damage and Repair Practices and Standards
Galvanic Action in Typical Indiana Limestone Connections	Wood & Steel Stud Construction
Safety Factors	Grouted Cavity Walls
Expansion Bolts for Anchoring Indiana Limestone	Cleaning Indiana Limestone
Panel Sizes in Indiana Limestone Usage	Water Repellents
Durability and Weathering in Contemporary Atmospheres	Stone Handling Lifting with Lewis Pins
Anchors and Supports	Joint Sealants for Indiana Limestone
Recommended Indiana Limestone Wall Heights	Hand Rails and Posts

CREDITS: Architects whose work is detailed in the Case History section

CSO Schenkel Shultz Architects	James Ingo Freed of Pei Cobb Freed & Partners	G. Cabell Childress, FAIA University of Denver Architect Emeritus
Mackey Mitchell Associates Architects	Cary Schafer Designs	Hardy Holzman Pfeiffer Associates
Pei Cobb Freed & Partners	Kohn Pedersen Fox Associates, P.C.	Morris Architects
C.W. Fentress & Associates, P.C.	Ratio Architects, Inc.	Tigerman Fugman McCurry Architects
Hanbury Evans Wright Vlattas & Company	Venturi Scott Brown and Associates	Geddes, Brecher, Qualls, Cunningham Architects
Shepley Bullfinch	Anderson Mason Dale Architects	Bohlin-Powell-Larkin-Cywinski Architects
SMBW Architects	Burt Hill Kosar Rittelmann Associates	Mark E. Rodgers, AIA University of Denver Architect
OWP&P Architects	Bauhs & Dring Architects and Planners	Rysavy & Rysavy
Notter, Finegold & Alexander, Inc.	Shepherd & Partners	Howard Needles Tammen & Bergendoff
Brubaker/Brandt, Inc.	John Burgee Architects with Phillip Johnson	Hartman-Cox Architects
Moody/Nolan, Ltd.	Cooler, Schubert & Assoc., Inc.	Lorenz, Williams, Lively & Likens
Barganier, McKee & Sims	Lawrence Halprin & Associates	Alvord • Burdick & Howson • Engineers
Hnedak-Bobo Group	Edward Larrabee Barnes Associates	Skidmore, Owings and Merrill
Hardwicke Associates Inc.	Browning • Day • Pollak Assoc., Inc.	
Desmond, Miremont, Burks		
NMT/Walk Jones & Francis Mah		

purpose of the institute

ILI serves the construction industry, the architectural profession and the limestone industry as a coordinating agency for the dissemination of accurate, unbiased information on limestone standards, recommended practices, grades, colors, finishes, and all technical data required for specifying, detailing, fabricating and erecting Indiana Limestone.

service to architects

Help in the use of Indiana Limestone is available to architects, designers and specifiers in the selection of grade, color and finish. We offer a Review and Comment Service for preliminary drawings to help assure compliance with industry practice and to suggest details and treatments for the best and least expensive use of the material. ILI will aid in soliciting budget and preliminary costing from its member companies. ILI will assist architects, contractors and building owners in solving design problems and in all questions relating to best usage, maintenance and other matters of interest to users.

Permission to copy, or otherwise use information, charts, graphs, diagrams, and other material appearing herein, which have been prepared by the Indiana Limestone Institute, its members or predecessors is routinely granted for the purpose of architectural construction specifications or other purposes directed and related to the use of Indiana Limestone for building. Information, charts, graphs, diagrams, and other material prepared by sources other than ILI, its members or predecessors may be restricted. Potential users of any material contained herein are urged to contact ILI regarding permission to publish or otherwise make use of these materials.

Extreme care has been taken in the preparation and presentation of all data and other information in the Indiana Limestone Handbook. ILI and its Technical Committees have made all reasonable efforts to insure that the information herein is accurate, and that any inferences based upon it are founded in conservative engineering and good testing practices. However, proper design and construction practice includes consideration of many factors and variables, and it is the province and responsibility of the designer and the builder to evaluate the proper application of the data and information herein to specific building or other construction projects. ILI and its committees do not prepare plans or specifications or engage in engineering calculations relating this data to specific projects and accordingly disclaim any liability or responsibility for any errors, oversights or omissions in the use of this Handbook material or in the preparation of plans, specifications or calculations in reliance of this Handbook.

contents

SECTION I page 3
general information

SECTION II page 12
recommended standards and practices

SECTION III page 47
product use

SECTION IV page 84
case histories

SECTION V page 125
specifications, technotes, glossary, index

SECTION I

general information

A Brief History of the Indiana Limestone Industry	4
Geological Formation	5
Chemical Analysis	6
Product Description	6
Seasoned Stone	7
Natural Bed	7
Physical Properties, Performance Tables, and Performance Characteristics	7-10
Classification of Indiana Limestone (Grading)	10
Staining and Efflorescence	11

A brief history of the Indiana limestone industry

Even prior to Indiana's admission to the Union in 1816, a light-colored, fine-grained native stone had been used by pioneer settlers for cabin foundations, door sills, milling burrs, and memorials. The stone was quarried with use of long star drills and wedges to separate blocks from the main deposit. The first organized quarrying effort of record was established in 1827 in southern Indiana near Stinesville.

Concurrent with the arrival of both north-south and east-west railroads into southern Indiana in the mid-19th century, the market for Indiana Limestone responded to architectural demand for stone of a light-neutral color to complement the various Revival styles of the era. The railroads themselves required stone for

bridge piers and for the increasingly grandiose terminals in the growing cities.

During this period, gang saws were introduced to replace the two-man crosscut saws previously used to saw block stone into slabs; the introduction of the channeling machine to the quarrying operation enabled the infant industry to double and triple production in succeeding years.

Extensive fires in the cities of Chicago (1871) and Boston (1872) added to Indiana Limestone's demand. It was apparent that of all of the commonly used materials, masonry showed the least fire damage, and limestone least of all.

Indiana stonework won awards of merit for quality at both the Philadelphia and New Orleans Centennial Expositions of 1876. Contracts for Indiana Limestone in two major public buildings in that decade, the Indiana Statehouse and the Chicago City Hall, established its reputation of superior weather resistance, ease of shaping, consistent quality, boundless supply and good public and architectural acceptance.

In the final decades of the 19th century, Indiana Limestone was chosen for an increasing number of city halls, statehouses and federal office buildings. To meet the demand for stone, the number of quarries doubled between the years of 1889 and 1895; stone fabrication shops in the southern Indiana production district doubled as well, although in this era most of the work was finished in local shops in destination cities. Banking houses, retail stores, hospitals, private residences, churches and office buildings, many built in the eclectic styles of the day, all demanded increasing amounts



▲ Quarry scene in Indiana Limestone district, circa 1865.

See page 49 for more information on the stages of production in Indiana Limestone quarries and mills.

Modern Indiana Limestone quarry. ▶



of the fine-grained, light-colored stone. The Cotton Exchange Building in New Orleans was the first major project in which limestone was shipped from Indiana cut ready to set. In the mid-1890s, George W. Vanderbilt set up a complete cut stone mill to fabricate Indiana Limestone for the Biltmore, his summer retreat in Asheville, North Carolina. The quarry in which the blocks were produced is still operating.

Limestone use continued to increase through the 1920s, and even into the depression of 1929-39. During this period, great technical advances were made in quarrying and fabrication techniques enabling Indiana Limestone to hold its competitive edge over the newer man-made products which were appearing on the market. During this era, the age of the “skyscraper,” knowledge about large buildings and their reaction to wind, thermal expansion and settlement brought about new construction techniques. Although these methods opened new markets for competitive materials as well, Indiana Limestone usage continued to increase, or decreased at a lesser rate than that of more expensive and less durable materials in the depression period.

During this time, the Empire State Building, the Department of Commerce, The Tribune Tower as well as many other major buildings were constructed of Indiana Limestone. Private owners, developers and government at all levels used limestone; their architects designed the material to fit the changing styles of the Art Deco period, and limestone producers developed machines which provided the new surface textures required. World War II effectively halted all construction not required for the war effort. In 1945, limestone production resumed with much of its previous vigor.

The Indiana Limestone Industry was able to weather the changes in its sales patterns forced by the international styles of architecture during the period between 1950 and the oil embargo of 1973, in which building products demanding huge amounts of energy to produce and use were extensively used. The world realized that fossil fuels are limited, and the value of Indiana Limestone as an efficient, low energy demand product was perceived by architects and their clients alike. Although the energy crunch of the late 1970s lost its crisis proportions during succeeding decades, the International Style of architecture had received a death blow. Eclectic new styles, known in general as Post-Modern governed the design of buildings, and interest in stone and stone looks increased. Post-Modernism welcomed stone, and its qualities of durability, beauty and designability, plus good thermal performance when properly used, made Indiana Limestone once again the material of choice. Indiana Limestone quarriers and fabricators developed new machines and methods to increase productivity;

sales increased in dollars and in cubic feet, and the industry prepared to enter the 21st century with renewed vigor and enthusiasm.

geological formation

Indiana Limestone (geologically known as the Salem Limestone) is essentially a monomineralic rock consisting of the calcium carbonate (CaCO₃) mineral named calcite. The calcite comes from the skeletal material (about 75 percent) that form the framework

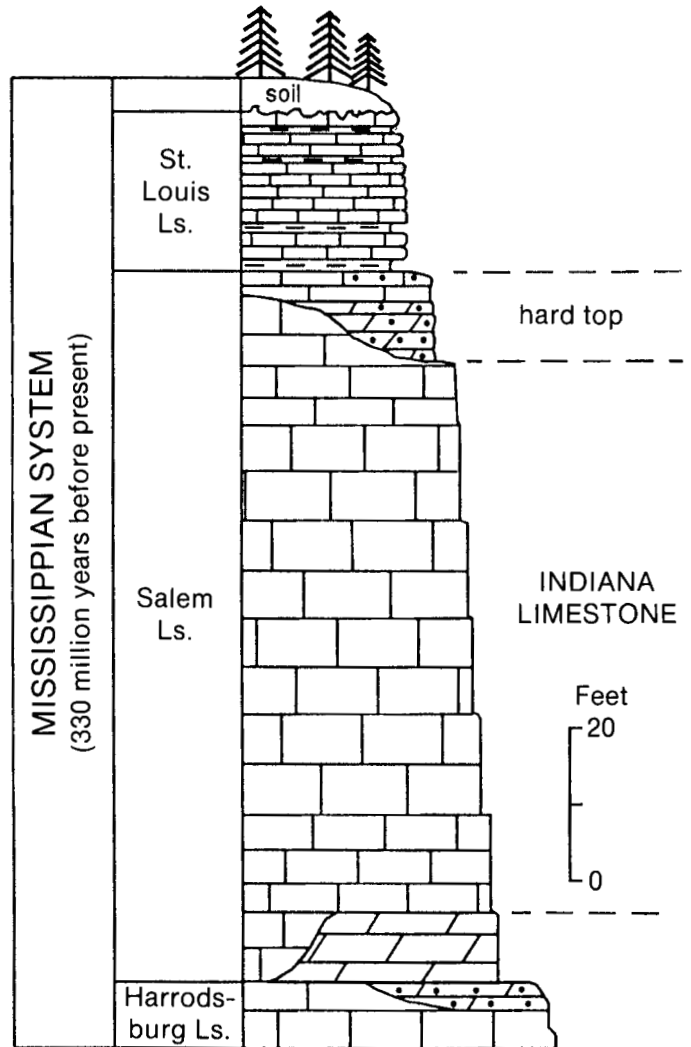

Stratigraphic section showing Indiana Limestone’s relative position in the Indiana stone deposit.
Courtesy Indiana Geological Survey

grains and from the cementing material (about 20 percent) that binds the grains together. Porosity (about 5 percent) and small amounts of non-calcareous material comprise the remainder of the rock.

Indiana Limestone was formed in a shallow sea that covered the Midwest, including the Bedford-Bloomington, Indiana quarry area, more than 300 million years ago dur-

ing the Mississippian geological epoch. This shallow sea was inhabited by a vast number of shell-protected organisms, chiefly bryozoans and echinoderms, although many members of a single genus of the foraminifers were also present. Shellfish of the brachiopods and mollusks and a few other forms of life also lived in the sea. The shells were moved, broken, crushed and ground, then re-deposited through the action of the currents. Finely divided calcium carbonate was produced during this process and adhered to many shells in a series of concentric layers to form oolitic (rock egg) grains, so named because of a resemblance to roe of fish.

As these particles accumulated and were buried on the floor of the sea, they were incorporated into rock through compaction, interlocking of grains, and cementation of the grains by enlargement of finely divided crystals either deposited with the shells or precipitated from supersaturated solution.

Indiana Limestone contains minute quantities of iron-bearing minerals, clay, and organic material thought to be residual from the soft parts of the tiny marine animals that inhabited the sea. Most of these dark materials are found between calcite crystals or the shell materials, and some shells and calcite crystals are darker than others. These dark-colored grains pepper the stone, particularly gray stone.

Microscopic examination of different pieces of stone shows that a change from gray to buff takes place in the deposit. Buff stone is ordinarily found above gray stone, and the change from gray to buff is brought about mainly by the oxidizing action of ground water moving down through the deposit. This oxidation changes the organic material from black through brown to light tan; and the iron-bearing minerals from gold or black through blackish, red, and orange to light yellow. As these materials become lighter, the calcite also becomes lighter. The end product is buff limestone. The gray stone is at a depth not affected by the oxygen in the ground water.

chemical analysis

The average analysis as developed by carefully prepared composite samples is given below.

	BUFF	GRAY
Carbonate of Lime	97.39	97.07
Carbonate of Magnesia	1.20	1.20
Silica	.69	.80
Alumina	.44	.68
Iron Oxide	.18	.12
Water and Loss	.10	.13
	<u>100.00</u>	<u>100.00</u>

product description

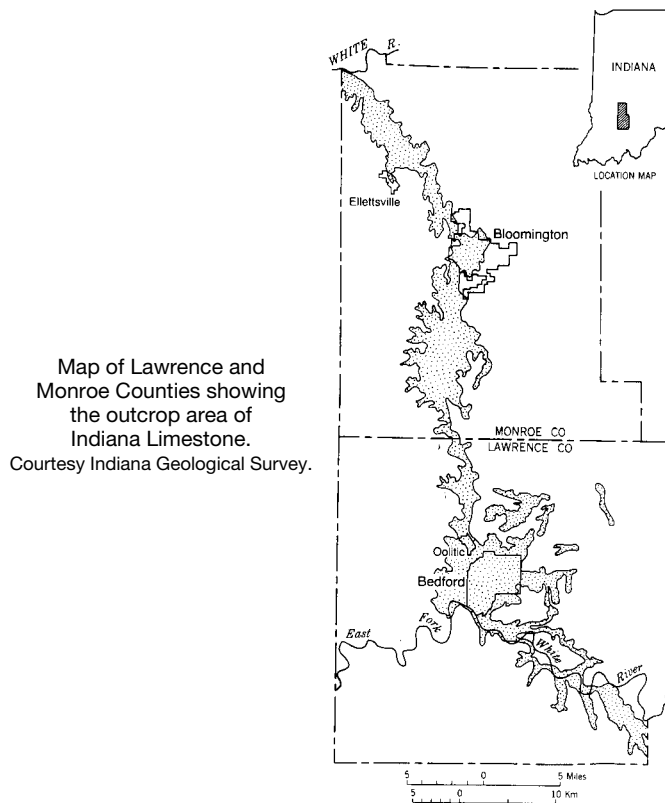

Indiana Limestone is a calcite-cemented calcareous stone formed of shells and shell fragments, practically non-crystalline in character. It is found in massive deposits located almost entirely in Lawrence, Monroe, and Owen counties in Indiana. This limestone is characteristically a freestone, without pronounced cleavage planes, possessing a remarkable uniformity of composition, texture, and structure. It has a high internal elasticity, adapting itself without damage to extreme temperature changes.

This stone combines excellent physical properties with a remarkable degree of machinability. This ease of machining provides complete flexibility of shape and texture at low cost.

The supply of Indiana Limestone is virtually unlimited. Geologists estimate that the product will be available for 500 to 600 years based on present extraction methods. A trend to underground quarrying would extend the supply to more than 1,000 years. Indiana Limestone is as close to an inexhaustible resource as exists on earth.

Over the past hundred years, Indiana Limestone has proved its ability to resist the forces of weather and pollution. Its qualities of strength and beauty continue to adapt themselves to the needs of contemporary architecture. See Durability Technote pg 137.

Floor-to-floor sizes are regularly produced for curtain-wall construction in addition to sizes for conventional masonry construction. Sills, coping, entrance features and similar trim items are long-time standards in Indiana Limestone.

Preassembled units such as window surrounds, shaped sills or headers with mullions attached as single units, and similar plant assembled sections provide design flexibility and low erection costs.

seasoned stone

When quarried, Indiana Limestone contains ground water. This is commonly known as quarry sap. Normally buff stone does not require seasoning beyond the usual sixty to ninety days quarrying, sawing and fabrication process.

For best immediate color uniformity, gray stone should be seasoned a minimum of six months prior to setting in the wall. This allows the organic matter in solution to stabilize. The organic matter will oxidize upon exposure to the elements causing gray stone to lighten in color with age.

Due to the seasonal nature of the quarry operations in Indiana, it is sometimes necessary to use unseasoned stone. This is an approved practice in the industry; any resulting discoloration will disappear, usually within a few months after the stone is set. To mitigate the poten-

tial for staining, the use of gray stone in interior applications should be limited to fully seasoned material.

Although ILI and its member companies urge contractors not to use the limestone shipper's celotex or similar pads as separators for long-term storage, this practice occurs. It can result in comparatively long-lasting figuring of the stone, especially in the case of stone containing quarry sap. Although most of these "pad marks" will ultimately go away by themselves, and can usually be removed with special efforts, stubborn marks occasionally remain. It is much easier to avoid this problem by using non-absorptive spacers which allow air to circulate. ILI or its member companies will be happy to comment to inquirers on the subject. (See Contractors Handbook on Indiana Limestone, p. 1.)

natural bed

Indiana Limestone is a sedimentary formation, but the deposition of the minute calcareous seashell is so uniform that no weak cleavage planes occur in the material. It can be machined or cut in any direction without danger of splitting.

However, because it is a sedimentary rock it does have a grain running horizontally in the deposit.

Stone set in a building with its grain running horizontally, as it does in the quarry, is said to be set on its "natural bed." Stone set with the grain running vertically is on "edge."

physical properties and performance characteristics

Being a natural product, Indiana Limestone's physical properties such as strength values will vary. The physical properties depend upon texture, cementing material, and degree of moisture.

The following test results are based on many samples tested over a period of years by the industry, the Indiana Geological Survey and the U.S. Bureau of Standards. Committee C-18 of American Society for Testing and Materials (ASTM) has developed many of the test methods used by the testing laboratories reporting these values.

performance tables

table I

In most cases, the design of Indiana Limestone for building requires the consideration of these three properties only. Values shown in Tables II and III are given for special reference. A Technote on safety factors governing Indiana Limestone design is available on request from ILI or member companies.

PROPERTY	VALUE	TEST PROCEDURE
Ultimate compressive strength dry specimens	4,000 psi minimum (see note a)	ASTM C170
Modulus of rupture dry specimens	700 psi minimum (see note a)	ASTM C99
Absorption	7 1/2% maximum (see note b)	ASTM C97

Compression and MOR results are for specimens loaded perpendicular to grain direction.

See pp. 16 and 20 for design load calculations and tables

Note a: Most Indiana Limestone production possesses values higher than these minimums, which are listed for engineering reference.

Note b: Indiana Limestone is available with lower values. Consult ILI for particulars.

Indiana Limestone is classified as a Type II Dimension Limestone under ASTM C-568, and meets or exceeds the strength requirements set forth in this classification. The flexure test often specified, ASTM C-880, was developed for stones thinner than the 2" which is the stated minimum for Indiana Limestone. As statements about limestone in C-568 embody the C-99 test for modulus of rupture, the inclusion of C-568 in specifications makes the numbers from C-880 meaningless. ILI recommends and uses ASTM test C-99 for modulus of rupture and believes this is more applicable to typical limestone uses.

table II

When used for flooring, paving, or steps, the abrasion resistance should be specified.

PROPERTY	VALUE RANGE (Abrasive Hardness)	TEST PROCEDURE
Abrasion resistance	6 minimum to 17 maximum (see note c)	ASTM C241

Note c: Factors in addition to abrasion resistance determine good performance in Indiana Limestone paving. Stone preparation and installation details are important in assuring acceptable performance. See pp. 30 and 63 for treatment of paving. Specify abrasive hardness of 8 for areas of heavy traffic such as bottlenecks and other pedestrian funnel areas. Specify abrasive hardness of 6 for light traffic such as plazas, patios, wide sidewalks and other such areas of light traffic expectation.

table III

Additional Properties

PROPERTY	VALUE RANGE
Bulk specific gravity	2.1 minimum to 2.75 maximum
Coefficient of thermal expansion	.0000024in/in/degrees F to .0000030in/in/degrees F
Modulus of elasticity	3,300,000 psi min. to 5,400,000 psi max.
Ultimate Shear Strength	900 psi min. to 1,800 psi max.
Ultimate Tensile Strength	300 psi min. to 715 psi max.
Thermal Conductivity (k)	6.5 B.T.U./hr./ft. ² /degrees F/in.
Weight	144 lbs./cubic foot
Fire Endurance—4" Thick Stone	1 hr. 12 min. plus hose stream (ASTM-E119)
Light Reflection (Interior Use)	50-55%

thermal properties

'U' factor (the heat transmission coefficient) is the reciprocal of the total resistance (R) to heat transmission of all the materials which make up a finished wall, measured over an area of 1 sq. ft. The formula is expressed

as $U = 1/R$ total. In these examples, a constant figure for 4" stone is used to show the comparative values of three types of wall construction:

4" stone 1" airspace 3⁵/₈" glass-wool bats 1/2" drywall	} 'U' factor = .0517
4" stone 1" airspace 8" concrete 3/4" M. L. and plaster	} 'U' factor = .32
4" stone 2" urethane 1/2" drywall	} 'U' factor = .06

values of mass in thermal engineering

COURTESY INTERNATIONAL MASONRY INSTITUTE

The 'U' factor is basically a steady-state calculation; that is, it does not consider the dynamics of the total building envelope. An additional consideration in thermal calculations is the effect of mass in heat transmission. Heavy walls exhibit a "fly-wheel" effect which retards the immediate impact of thermal loads. Massy materials, such as Indiana Limestone, react slowly to temperature changes which amounts to an inertial resistance to change. This creates a time lag which is advantageous in designing HVAC systems.

Storage capacity in the building envelope reduces the structure's maximum heat flow and thereby the peak-load which determines the size requirement of the HVAC equipment. Buildings with walls exhibiting poor thermal storage capacity require larger equipment to maintain a stated design temperature; the larger the storage capacity of the exterior walls, the smaller and less expensive the HVAC system needed. Heat stored in massy walls tends to be transmitted in low-load time, and in many locations actually reduces the required night HVAC requirements.

The 'M' factor is demonstrated in the accompanying graph. Based on degree days and wall mass expressed in pounds per square foot, the graph, used in conjunction with the heat loss formula, allows calculation of thermal storage values in walls of varying weights. Note that the correction values are conservative and propose the least amount of change to be considered. Where specific information for any area shows that lower correction values are applicable, they may be substituted.

color value

The chart at right illustrates the value of heavy, light-colored walls in air conditioning engineering. During the crucial mid-afternoon hours, west walls in identical locations register temperature differentials of more than 25 degrees F based entirely on their color and mass.

sound transmission

The weight of the walls in a building has a direct bearing on the sound transmission factor of the walls. The heavier the wall, the greater its resistance to sound transmission. This is due to the fact that the heavier walls are more difficult to set in motion by sound waves. The

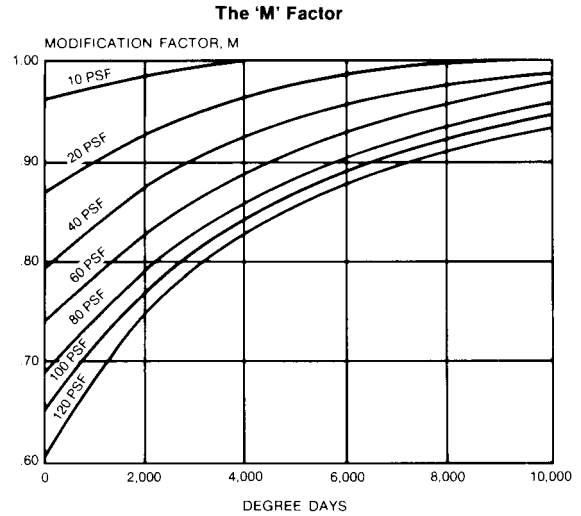

How To Figure Heat Loss

The formula for calculating heat loss that allows for the thermal retention effects of mass is as follows:

$$H_1 = M A U (t_i - t_o)$$

where:

- H_1 = heat loss transmitted through the walls or other elements of the building envelope, Btu per hour.
- M = modification factor taken from graph above according to degree days of building location and weight of building walls or other elements.
- A = area of the walls or other elements, square feet.
- U = overall coefficient of transmission of the walls or other elements, Btu per hour per square foot per degree F temperature difference.
- t_i = indoor design temperature, degrees F.
- t_o = outdoor design temperature, degrees F.

Total Equivalent Temperature Differentials—West Wall

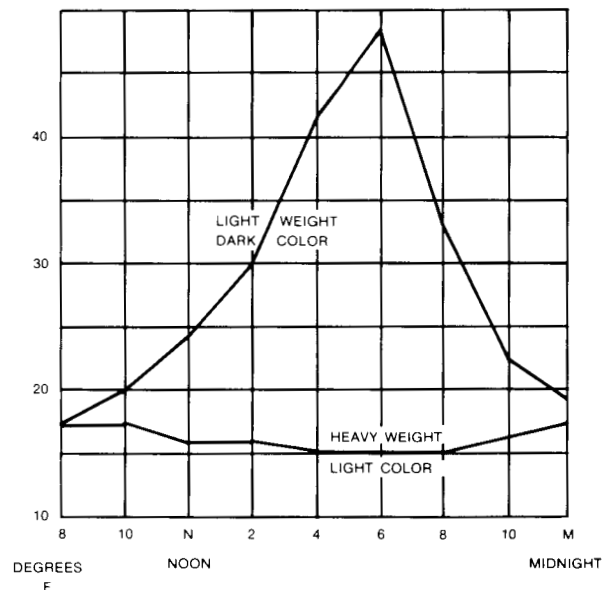

sound itself does not actually flow through a wall. It simply moves the wall to reradiate sound on either side. Therefore, the transmission of sound is determined almost entirely by the weight of the wall.

The frequency of the sound wave must also be considered. High frequency sound waves vibrate a wall less than low frequency sound waves. In other words, the inertia is higher if the sound wave travels faster.

A material having high mass will block the transmission of high frequency sound waves while a material having stiffness will block the transmission of low frequency sound waves. Indiana Limestone has both.

The sound reduction factor in decibels is proportional to the logarithm of the weight per unit area. The chart below shows the approximate reduction factor for various wall thicknesses.

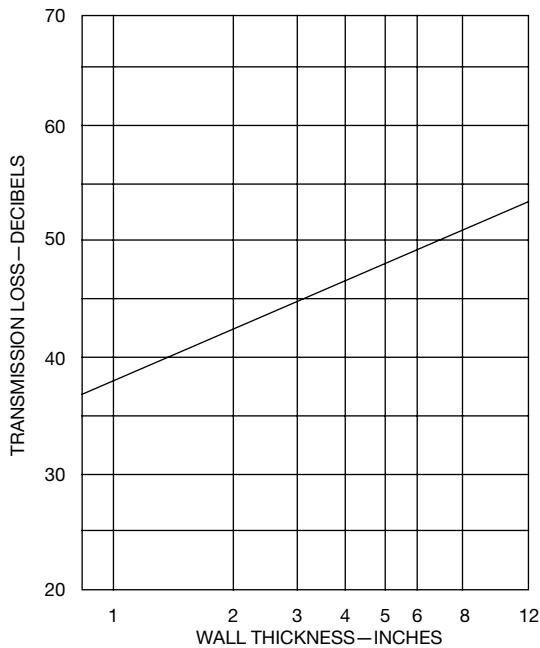

classification of indiana limestone

ILI classifies Indiana Limestone into two colors and four grades based on granular texture and other natural characteristics. When specifying Indiana Limestone it is necessary to identify both the color and grade required as well as the surface finish to be applied to the stone. (See Specifications for Cut Indiana Limestone, p. 126, see Finishes on p. 48, see How to Use the Indiana Limestone Grading System on p. 50.)

GRADE AND COLOR CLASSIFICATIONS

		COLOR	
		BUFF	GRAY
GRADE	SELECT	SELECT	
	STANDARD	STANDARD	
	RUSTIC	RUSTIC	
		VARIEGATED	

COLOR DESCRIPTIONS

Buff—varies from a light creamy shade to a brownish buff.

Gray—varies from a light silvery gray to shades of bluish gray.

GRADE DESCRIPTIONS

The ILI classifications are based on the degree of fineness of the grain particles and other natural characteristics which make up the stone. The structural soundness of each of the grades is essentially identical.

As a natural product, Indiana Limestone contains at least a few distinguishable calcite streaks or spots, fossils or shelly formations, pit holes, reedy formations, open texture streaks, honeycomb formations, iron spots, travertine-like formations and grain formation changes. However, through the years, one of the pleasing features of Indiana Limestone which has made it adaptable to the various architectural styles is that, as these do not exist in large, noticeable concentrations from stone to stone, one piece looks very similar to another with no discernable pattern of these natural characteristics. For this reason, Indiana Limestone does not lend itself to pattern blending as do stones which have characteristics such as specifically pronounced veining which exists from stone to stone.

1. Select —Fine to average-grained stone having a controlled minimum of the above characteristics.
2. Standard —Fine to moderately large-grained stone permitting an average amount of the above characteristics.
3. Rustic —Fine to very coarse-grained stone permitting an above-average amount of the above characteristics.
4. Variegated —An unselected mixture of grades 1 through 3 permitting both the buff and gray colors.

Notes:

- A. It is advisable that all stone for each project be furnished from a single quarry. This should result in the best possible color control.
- B. VARIEGATED stone will contain an uncertain percentage of the individual stones containing both colors while other stones may be all buff or all gray. When both colors occur within a single stone, the dividing line is usually readily discernible, and may be horizontal, vertical, diagonal and/or curved. The degree of contrast between the two colors, whether they appear in a single stone or in stones of solid individual colors, may be readily apparent or nearly indiscernible. Neither fabricator nor erector will attempt to control the location in the building of panels or individual stones according to their natural variations of color or texture.
- C. Since it is impossible to show all natural characteristics by sample, the approval sample should be used only as a general guide to final building appearance. Characteristics noticeable at arm's length will appear differently when viewed in the building at normal distance.
- D. As stone sizes increase, GRADE selectivity decreases until it may no longer be possible to classify SELECT or STANDARD grades according to ILI Classifications. Color, stone size and project size thus become the governing criteria. Designers and specifiers are urged to consult ILI or its member companies for specific current information.

Note: Large-scale samples, including sample walls (mockups) complete with connections and joint closures, can be helpful in selecting stone color and quality. These constructions should be preplanned and included in bid specifications where their additional expense is warranted.

staining and efflorescence

Alkali Stain

Staining or discoloration on Indiana Limestone in new work is known to occur when conditions favoring its development exist. Those conditions can be avoided by correct design and installation procedures.

The most common problem is alkali stain. It takes the

form of a light golden to dark brown discoloration. This stain is caused by alkali-charged moisture which permeates the limestone from its back or bottom bed. It cannot be produced in objectionable form by moisture absorbed through the stone's exterior face. Ground moisture absorbed by the stone's face when below grade is an exception to this rule.

The source of the alkali is usually nearby concrete walls, floors, or grade. The moisture may be rainwater, wash from concrete pours, excess moisture in mortar, or moisture from or at grade. This moisture picks up water-soluble free alkali from various sources as it migrates to an evaporation surface at the stone's above-grade face. Alkali-laden moisture moving through the stone dissolves minute bits of organic matter. The material is transported to the face of the stone as the moisture moves toward the face. The moisture then goes off as vapor, leaving the alkali and organic matter at the surface in the form of stain.

Efflorescence

The mechanics of alkali stain are identical to those of efflorescence, although its chemistry is different. The moisture typically picks up sulfates of sodium, calcium, magnesium, iron, and potassium from sources within the wall. The dissolved chemicals are deposited at and under the stone's surface in the form of a whitish bloom or powder.

This material is somewhat more soluble in water than is the staining material, and for this reason usually is more easily removable.

Damage from efflorescence can occur when crystal growth occurs below the stone's surface. It causes stress on pore walls. The result is flaking, or exfoliation.

Avoid contact between soil and stone. Dampproofing treatments of either a bituminous or cementitious nature may be used as a barrier to the ground water or construction moisture causing these stains. See pp. 30-32.

The old adage common to all masonry applies—KEEP THE WALLS DRY.

Additional information on this subject is contained in ILI's booklet, *How To Avoid Small Area Stains and Blemishes*, copies of which are available to architects and specifiers on request.

SECTION II

recommended standards and practices for design and construction

Design and Construction Criteria	13-15
Panel Size – Design Factors	15-18
Wind Load Calculations	16
Anchor Guide	17
Freestanding Stones	17
Parapet Walls – Details and Calculations	18
Anchors, Supports and Embeds	18-21
Joints:	
Mortar and Pointing	22-24
Cold Weather Setting – IMI All Weather Council Recommendations	24
Sealant Systems	25
Attachment to Steel Studs or Wood Studs	25-27
Joint Movement	27
Expansion Joints & Control Joints	27-29
Pressure Relieving Joints	29
False Joints	30
Dampproofing	30
Water Repellent Treatments	31
Graffiti Repellents	32
Flooring and Paving	32-33
Reglets	33
Flashing and Metalwork	33
Weeps and Wicks	34
Carving, Ornament and Sculpture	34
Inscriptions	34
Fabrication Tolerances and Definitions	35-36
Lintel Table	37
Arch Theory & Practice	38
Using Steel Lintels with Indiana Limestone	38
Cleaning New Construction	38-39
Indiana Limestone in Restoration	39-42
Seismic Considerations	42
Storage and Handling	43-44
Metric Equivalents	45
Masonry Wall Nominal Heights	46

design and construction criteria

Note: Many of the drawings and illustrations in this Handbook are point-specific and, as such, may omit some elements required by good practice. Further, there may be equally sound alternatives to these details. For additional information, users are urged to contact ILI or its member companies.

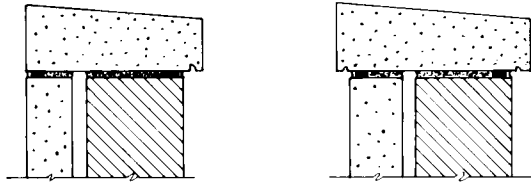

FIG. 1

- Pitch coping stones toward the roof to avoid discolorations on the exposed face and walls. (See p. 66 for joint treatment in copings.)
- It is not necessary for backs of stone above a roofline to be finished.
- Vent attics over porticos to prevent condensation entering the wall and filtering through the joints to the face of the stone.
- Provide washes and drips on projecting stones, with a minimum projection of 1³/₈" from wall to face including the drip. (See Fig. 2.)
- Do not use stone for concrete forms.
- Butt joints are usually less expensive on smooth finishes; quirk joints on textured finishes. (See Fig. 3.)
- Prevent physical contact between the back face of stone walls and columns, floor slabs, and the end beams; expansion can push the stone out.

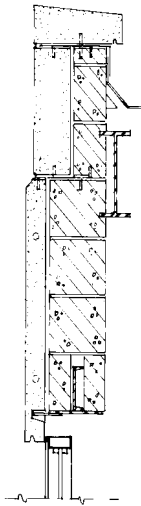

FIG. 2

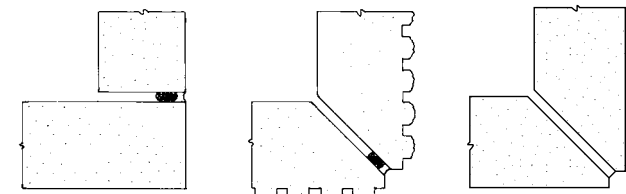

FIG. 3



RECOMMENDED

NOT RECOMMENDED

- For economy, design rustication only on one side of a joint. (See Fig. 4.)

- If exposed stone patios occur over a heated room, insulate the ceiling of the room. Warm stones absorb moisture, and a sudden drop in outside air temperature may freeze and crack the stone. (See p. 31 and 63 for recommendations on large horizontal areas.)

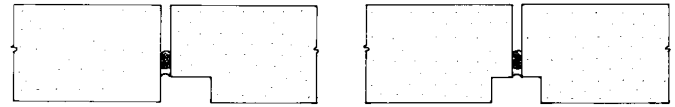

RECOMMENDED

NOT RECOMMENDED

FIG. 4

- Where design allows, step the foundation in sloping terrain to avoid placing limestone below grade. If such installation is unavoidable, utilize the trench and the coating in Fig. 5. Note that bituminous coating, if exposed above a receding grade, may become a visible black line. (See p. 30 on dampproofing.)
- If accessory elements such as metal caps, flashings or similar are attached to the stone with closely-spaced expansive anchors or with potentially corrosive anchors, distress in the stone and possible spalling can occur.

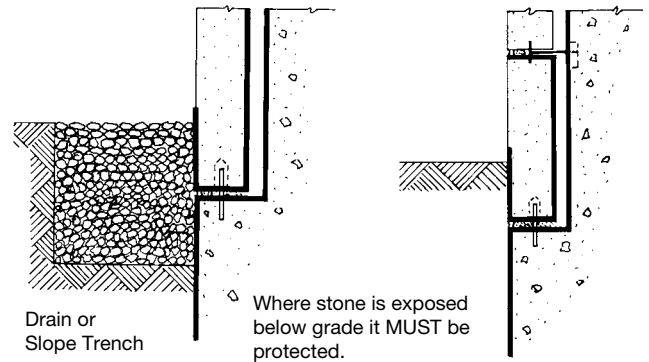

HEAVY LINES INDICATE DAMPPROOFING

FIG. 5

- Specify mortar joints to be tooled for proper moisture resistance. Where sealants are used, follow manufacturer's specifications to obtain the desired joint profile and adherence to inner joint surfaces. (See p. 25 on sealants.)

- If false joints are used, they may be pointed to match other joints.

- Where masonry butts against a stone pilaster, or at building corners, specify a sealant joint. Long vertical mortar joints are difficult to compress, and may tend to fail.

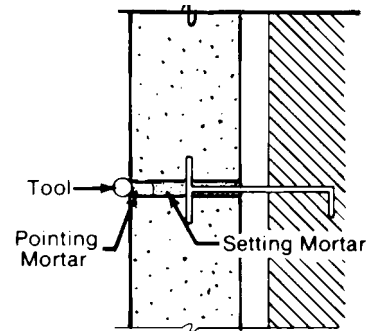

Tool the pointing mortar to compact the joint.

FIG. 6

- For economy, maintain return heads the same depth as the normal stone facing thickness. (See Fig. 7.)

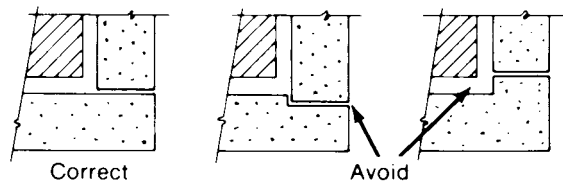

Return Heads
FIG. 7

- Pierced flashing should be resealed.
- Steel lintels carrying stonework should have ample stiffness to carry total superimposed load with a deflection of the lesser of 1/600 of the clear span or 1/4". Rotation of the lintel due to eccentric load should be considered in determining total deflection.
- Incorporate a 1" minimum clearance between stone and all structural members.
- For economy, step down coping on circular sloping retaining walls.
- While jointing is a part of the design and should be placed as desired, avoid conditions which place heavy loads on long, narrow stones. Where design requires such conditions, use steel angles to relieve the weight and to avoid cracking the smaller stones.

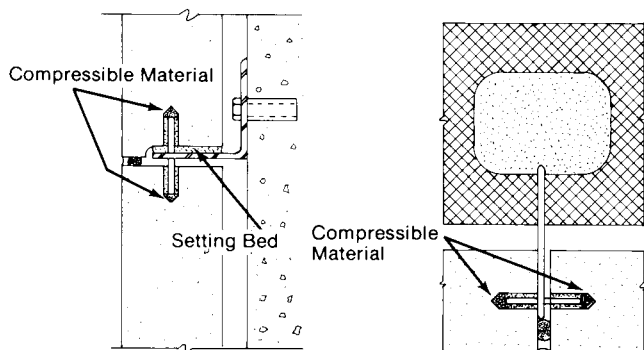

FIG. 8

- Dowel pins **MUST NOT** be embedded solidly when installed through a relieving angle at an expansion joint or in horizontal tie-backs. Compressible material should be installed at the base of dowel pin holes to allow for thermal expansion. Maintain empty space **BELOW** the relieving angle for the same purpose. (See Fig. 8; also Fig. 26, p. 30.)
- Avoid the use of continuous shelf or support angles except at bottom beds. (See Fig. 9.) For additional information on the need for shelf or support angles, see the ILI Technote on Recommended Indiana Limestone Wall Heights on page 150 of this Handbook.
- When possible, avoid setting stone with mortar in extreme cold. Stonework set in cold weather may

expand and crack mortar bond in warm temperatures. Install sealant joints or use Cold Weather Masonry Procedures. (See p. 24.)

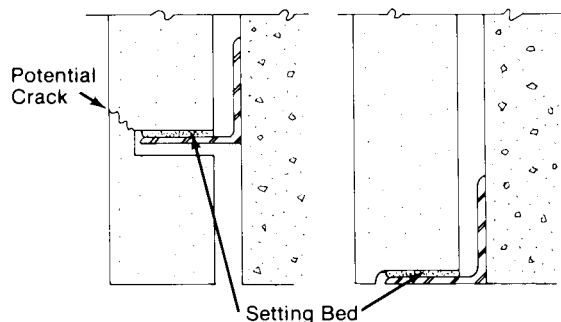

FIG. 9

- A lean pointing mortar will usually perform better than a strong one. While pointing reduces leak potential whether the joint is thoroughly filled or not, a strong mix may cause spalling at joints.
- Cavity walls should be kept clear of mortar droppings during construction. **DO NOT POUR THE CAVITY FULL OF GROUT.** (See Fig. 10 below, and ILI's Technote on Grouted Cavity Walls on page 150.)

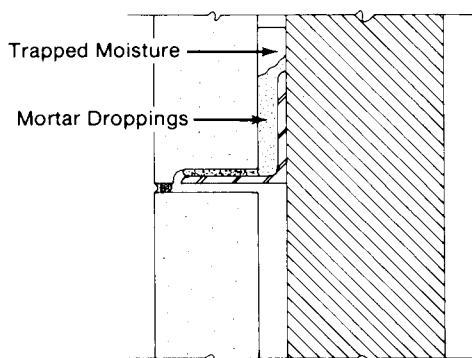

FIG. 10

- In mortar systems, all mortar joints between stones should be thoroughly filled. The front 1/2" to 1 1/2" should be filled with pointing mortar after the setting bed has set. (See Fig. 11. See also Fig. 6, on page 13, and POINTING, p. 23.)
- The use of calcium chloride or other salts which act as accelerators or retarders in mortar are not recommended in setting stone. (See p. 24 for Cold Weather Setting Procedures.)

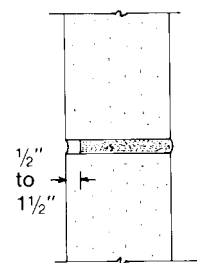

FIG. 11

- Do not pour concrete against unprotected stonework. Alkali from the concrete will stain stone.
- Store stone clear of the ground and protect adequately from the elements and construction traffic.

Special precautions should be taken when stone is stored over yellow or red subsoil. (See Storage and Handling, page 43.)

- Place an adequate number of setting pads in the horizontal joint **under heavy stones** in order to sustain the weight until the mortar has set. These pads should be relatively compressible so they will deform and conform to the irregularities of the joint surfaces. (See Fig. 12.)

- Lug sills should be bedded at the ends only. After the walls are completed, the joints under the sills should be cleaned, filled, and pointed. This will avoid cracking the sills from wall settlement.

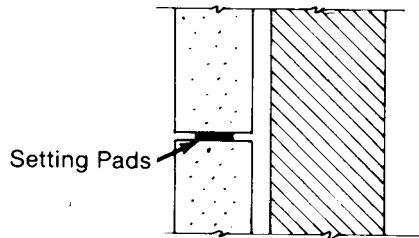

FIG. 12

- Be sure that all projecting courses, sills, entrances, columns and column covers and other stone elements exposed to traffic of the trades and mortar droppings are properly protected during construction. Use galvanized nails in mortar joints for support, or galvanized steel straps.

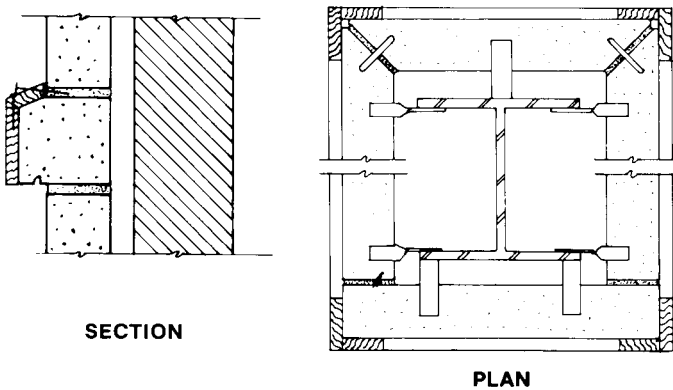

FIG. 13

- Do not permit wash from concrete floors or scaffolding to run down onto or behind stone walls.
- Always cover walls and openings adequately at night and during rains.** This will help prevent staining and efflorescence. **Failure to do this is a source of trouble, dissatisfaction, and expense.** (See Fig. 14.)

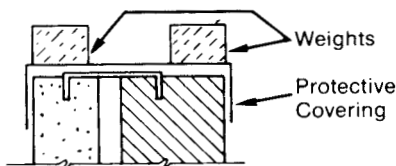
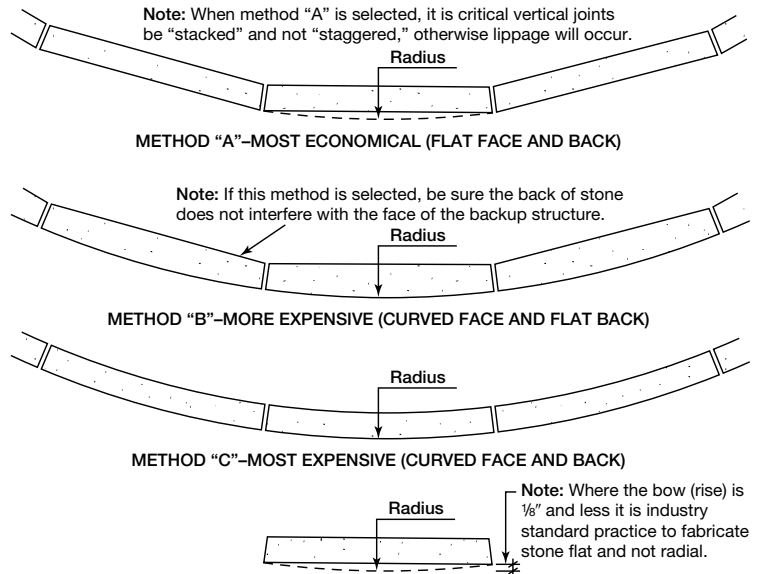

FIG. 14

RADIAL STONE



panel sizes

The panel sizes shown are the maximum recommended **FOR EFFICIENT FABRICATION AND HANDLING.** Larger panels are available in either monolithic stones or epoxy assemblies. For information on larger units, consult ILI or member companies.

NOTE: Two-inch thicknesses in Indiana Limestone wall panel work should be considered only in those applications where grasping systems specially designed for thin stone can be used. The anchors and supports ordinarily used in three-inch and thicker stones can often be used for thinner materials, but wind loads and other building dynamics become more critical as stone thickness is reduced. Fabrication, handling and erection procedures associated with conventional erection methods often produce greater costs when applied to thin stones. For most purposes, the conventional support systems should be limited to three-inch and thicker stones.

Use of the various grid systems and other specialized grasping methods should be considered for stones of less than three-inch thickness. ILI and its member companies will be happy to consult on this question.

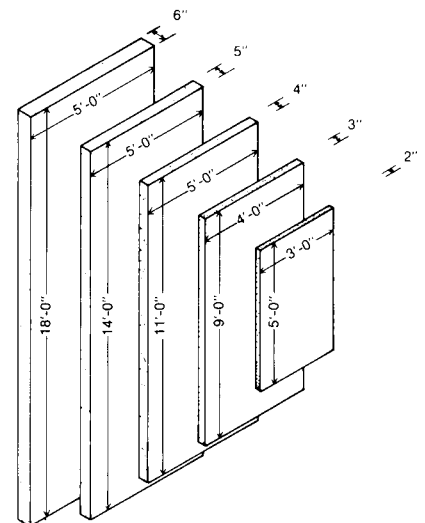

WIND LOADING OF PANELS

The chart, table, and accompanying map are reproduced for the convenience and general information of designers in evaluating required panel thickness for various spans and wind loads. Local codes for your area should always be consulted. Required design wind loads may be higher or lower than indicated here. Note that seismic loads should also be considered and, in some cases, may control.

Table 1 is a graph showing minimum stone thickness required for various vertical spans based on wind loads from 10 to 60 psf.

To use this graph, first locate the panel span on the vertical axis. Then move horizontally to intersect the required design wind load. This point of intersection determines the required panel thickness — interpolation is acceptable. If this point of intersection is above the desired panel thickness, either a thicker panel or a different anchor layout than top-bottom must be considered.

Note that anchor layout, including the number, type and location of stone anchors, may be affected by the pull-out capacity of the stone, the allowable capacity of the anchor itself, the capacity of the back-up or other factors. This should be evaluated and determined by appropriate engineering analysis.

If the stone has a MOR higher than 700 psi, stone thickness or allowable vertical span may be adjusted accordingly based on engineering analysis.

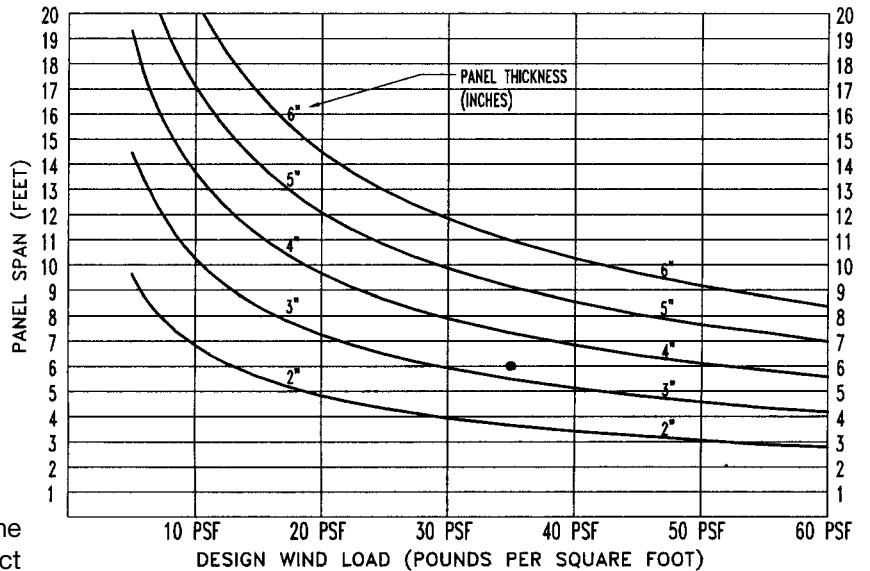

TABLE 1

The thickness and vertical spans shown were calculated based on the following:

1. The panel is anchored at top and bottom only at nominal quarter or fifth points and may be evaluated for vertical one-way bending.
2. Wind load is uniformly distributed on the face of the stone.
3. Maximum allowable bending stress (tension) is 87.5 psi, based on a modulus of rupture of 700 psi and a safety factor of 8 to 1. For wind or seismic loading, a 1/3 stress increase is allowable if permitted by the governing local building code.
4. The panel is not subjected to any gravity bending moments.
5. This chart is based on the following general equations:

$$t = .0926 \times h \times (WL)^{1/2}$$

$$h = (10.802 \times t) / (WL)^{1/2}$$

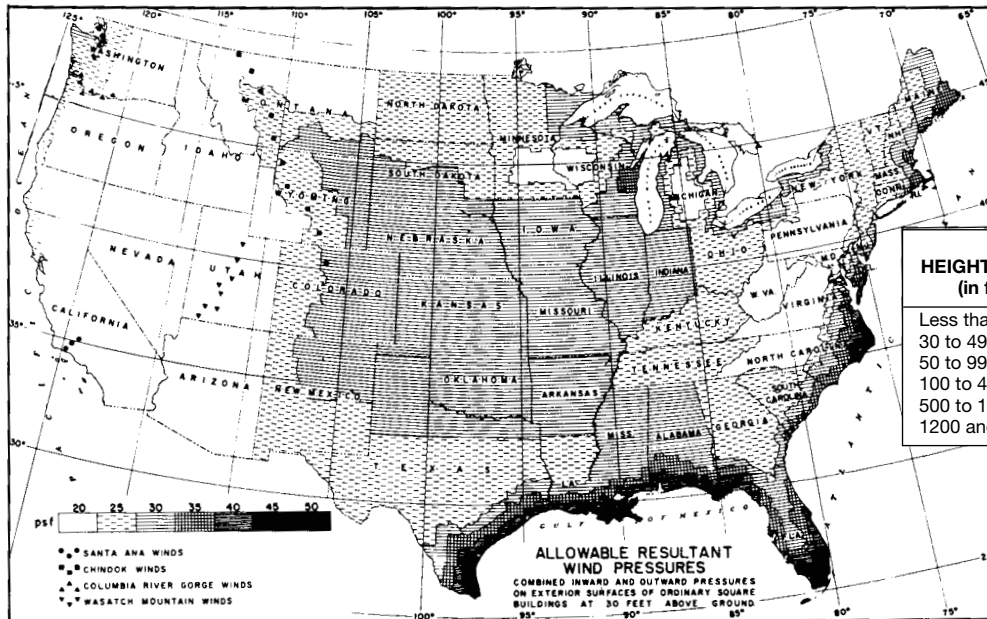

HEIGHT ZONES (in feet)	WIND-PRESSURE-MAP AREAS (pounds per square foot)						
	20	25	30	35	40	50	
Less than 30	15	20	25	25	30	35	40
30 to 49	20	25	30	35	40	45	50
50 to 99	25	30	40	45	50	55	60
100 to 499	30	40	45	55	60	70	75
500 to 1199	35	45	55	60	70	80	90
1200 and over	40	50	60	70	80	90	100

The figures given are recommended as minimum. These requirements do not provide for tornadoes.

"Reproduced from the 1979 edition of the Uniform Building Code, copyright 1979, with permission of the publishers, The International Conference of Building Officials."

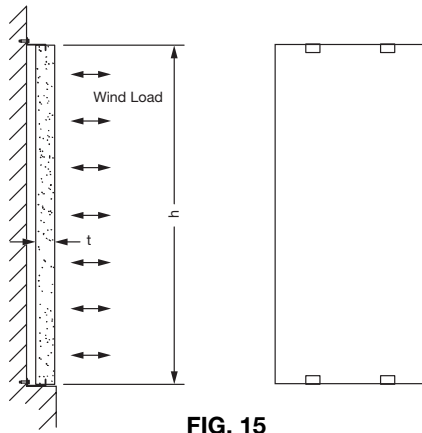

FIG. 15

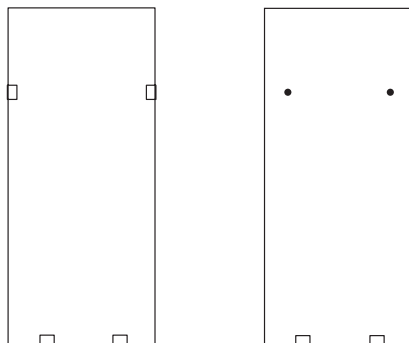

FIG. 16

anchor guide

Following are some general guidelines for anchorage design and layout. These are based on discussions with stone cladding design specialists. They are guides only and should be tempered by engineering analysis and/or specific project requirements.

1. Simple anchor designs and simple anchor layouts are preferred. Complex layouts are often statically indeterminate. Even with computer-aided analysis, many significant assumptions must be made.
2. Except for small panels or copings, use not fewer than four anchors per stone panel. Two anchors in the top bed and two in the bottom bed is a common layout. See Figure 15.
3. Locating anchors at fifth points generally provides the best load and stress pattern in the panel. Quarter point locations sometimes work better with jointing patterns and are commonly used. Top-bottom anchor layouts at quarter or fifth points often permit one-way bending analysis.
4. An important consideration and goal in determining location and number of anchorage points is to minimize bending stress in the panel. If a top-bottom anchor layout results in unacceptably high bending stresses in the panel, some other anchor layout or thicker stone should be considered. For instance,

instead of top-bottom anchors, a layout with anchors in the bottom bed and at some distance down from the top bed might be considered. See Figure 16.

5. Statically indeterminate anchorage patterns may be feasible in some cases. But analysis of load distribution and bending stress with such patterns is complex and such anchorage patterns can be effective only if attached to a back-up which is substantially stiffer than the stone.
6. Another important consideration in location of anchorage points is to minimize loads at these points. Symmetrically located anchors usually achieve equal distribution of load. Non-symmetrical anchor layouts result in higher anchor loads at some locations. This may affect anchor choice.
7. Avoid anchoring panels across a potentially moving joint such as a relief joint or expansion joint. If this cannot be avoided, anchors with slip capability will be required. Friction-induced slip loads must be considered.
8. Anchorage points near gravity supports should be located at, or as close as possible, to the gravity support points.
9. Gravity support at not more than two points for a panel is usually preferred.
10. Features such as rustications and false joints reduce effective panel thickness as regards bending and anchor capacity.
11. Fasteners for stone anchors will almost always penetrate dampproofing membranes or flashings. This fact should be accounted for in design of these items and all such penetrations should be appropriately sealed.

freestanding stones

Signage stones, monument stones, and other tall freestanding stones should be properly anchored to prevent overturning. Wind load, seismic load, and differential expansion and contraction should be considered. If the stone is placed in an area of public access, design should comprehend pedestrian loads including, but not limited to, pushing, pulling and possibly climbing on the stone.

Stone should be set with a minimum of two stainless steel dowels in the bottom bed to prevent movement, even where overturning is not a consideration. All-threads or deformed bars may be required in some cases. Bottom bed of stone should be square. Stone should be set plumb and true in a properly sized mortar

or grout bed. In some cases epoxies may be required. Horizontal bearing surfaces immediately under the stone are recommended. Adjacent surfaces should be properly sloped and drained away from stone. Stone should not be set on floating slabs or across joints, as these may shift. In locations where frost heave can occur, consider extending the foundation below the frost line. Where applicable, proper dampproofing procedures should be followed. Further, while ILI maintains a statesman-like silence on the use of water repellents, signage is one area where they can sometimes be beneficial, assuming proper installation procedures are followed. Additional information is available on pages 30 to 32 of this handbook and through ILI and its members.

parapet walls

Parapet walls are frequently subjected to extremes of moisture infiltration and thermal changes causing movements differing from those in the wall below which is exposed on one side only. Through-wall flashing often provides a plane of weakness. In addition, parapets lack the weight necessary to hold masonry units together.

Many problems can be avoided by facing the back of the parapet with stone to reduce differential thermal expansion in materials. Solid stone parapets are often used for this purpose with flashing placed in a reglet in back and the joints caulked with a permanent caulking compound (Fig. 17).

Where copings are used, regardless of their material, attention to joint design, material, and maintenance can prevent leakage and water damage. In general, use high-performance sealants as the weather-face for coping joints, and to act as expansion joints.

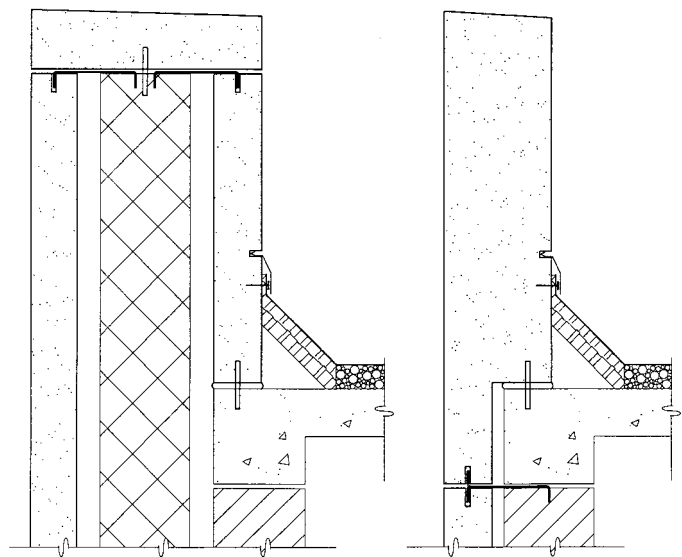

FIG. 17

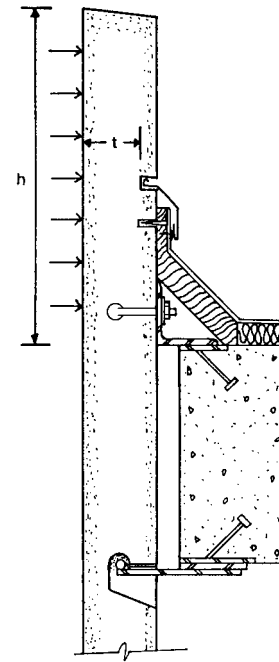

FIG. 18

WIND LOADING OF PARAPET WALLS (See Fig. 18)

When a limestone fascia panel extends past the roof line forming a parapet, the following formulas may be used to calculate the minimum stone thickness to resist wind loading, based on $t = h\sqrt{.0343WL}$.

- For WL = 10 psf then $t = .586h$
- For WL = 20 psf then $t = .828h$
- For WL = 30 psf then $t = 1.02h$
- For WL = 40 psf then $t = 1.17h$
- For WL = 50 psf then $t = 1.31h$

WL = Wind Load—pounds per sq. ft.
 t = panel thickness— inches
 h = parapet height—feet

Based on MOR = 700 and 8 to 1 safety factor

A Technote on safety factors governing Indiana Limestone design is available on request from ILI or member companies.

anchors, supports and embeds

Stone fabricators are usually suppliers of limestone only. They provide the stone with the required holes, slots, chases and sinkages for the anchoring system, steel, or other non-corrosive metal, but seldom provide the anchors themselves. This responsibility falls usually on the mason, the erector, or may be assigned by the general contractor, though the stone fabricator will assist in recommending anchor systems. It is standard practice

for the architect to indicate generally the anchor system for each typical condition, including anchor type, size, and location, and to judge and approve or change the extension of that system shown on shop drawings. This is in line with standard practice and is not a result of applied engineering. The proper size and type of anchor depends upon design loads and specification requirements. The correct anchor type and size should be determined by engineering analysis which the Indiana Limestone industry does not provide as part of their contract without a specific prior agreement.

ANCHORS

The term “**anchor**” refers generally to the straps, rods, dovetails and other connections between stone and structure. While most anchors are intended to maintain stones in their vertical positions rather than bear weight, certain anchors are structural and their use eliminates the need for other supports. All anchors in Indiana Limestone should be stainless steel, or other non-corrosive metal. In practice, anchors are embedded in the stone with mortar, sealant, or other non-expansive, stable material.

SUPPORTS

Supports by definition are not embedded in the stone, but support its weight. They may touch or be adjacent to the stone. Supports are typically A36 steel, but may be any metal of adequate strength. Supports should have at minimum (a) a shop-coat of rust protection, applied after forming and de-greasing, and (b) a job-coat of compatible rust protection applied after supports are installed on the structure. Hot-dip galvanized supports are acceptable; SS supports are not required except under special circumstances. Any damage to these coatings as a result of installation work, cutting or drilling, must be repaired with a compatible rust protection coating.

EMBEDS

Embeds may include plates with headed studs, angles with headed studs, adjustable inserts, etc. These will be malleable or galvanized malleable iron which will be embedded in concrete or cmu. No shop drawings/location drawings are furnished by the stone fabricator.

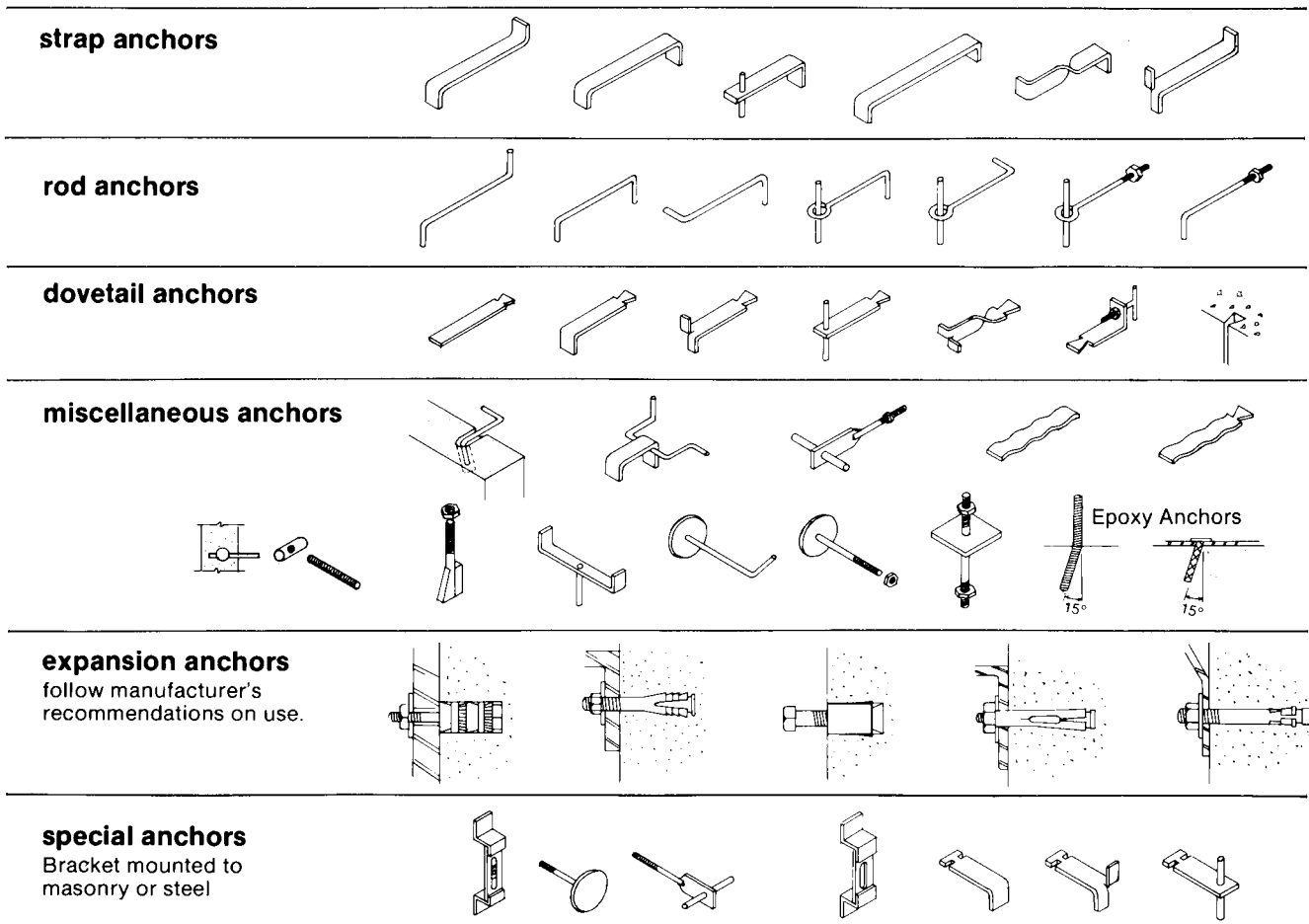

angle/plate supports

In support systems for Indiana Limestone utilizing steel angles attached to the building's frame, erection labor cost is the prime factor determining expense. Therefore, system components should be designed for speed and ease of erection. Sufficient strength in support members is of first importance, however; the following table is a guide to conservative support design.

ASTM A36 steel (36,000 lb/in² yield strength) is commonly used angle material. The American Institute of Steel Construction Handbook assigns a maximum allowable bending stress of 23,760 lb/in² ($F_b = 0.66 \times 36,000 = 23,760 \text{ lb/in}^2$) for this type steel. The ILI table following was developed using $F_b = 18,000 \text{ lb/in}^2$ bending stress. Therefore, this table and formula will produce conservative support design. The table and formula provide a method to determine the weight which a 1" width of steel will support. By adjusting the steel thickness, the required support length can be determined for various increments of cantilever (L).

For example, a 3000 lb load bearing on a support which is cantilevered 3" will require 12" of 1/2" thick steel, or 21.34" of 3/8" thick steel.

THICKNESS			MAXIMUM ALLOWABLE LOAD (P) PER 1" WIDTH OF STEEL SUPPORT															
h	^h _{decimal}	h ²	L=1 1/8	L=1 3/8	L=1 3/4	L=2	L=2 1/4	L=2 1/2	L=3	L=3 1/2	L=3 3/4	L=4	L=4 1/2	L=4 3/4	L=5	L=5 1/2	L=6	
1/4	.25	.0625	166.6	136.3	107.1	94	83.3	75	62.5	53.6	50	46.9	41.7	39.4	37.5	34.1	31.3	
5/16	.3125	.0976	260.4	213	167.4	146.4	130.2	117.1	97.6	83.7	78.1	73.2	65.1	61.6	58.6	53.2	48.8	
3/8	.375	.1406	375	306.8	241	210.9	187.5	168.7	140.6	120.5	112.5	105.4	93.7	88.8	84.4	76.7	70.3	
7/16	.4375	.1914	510.4	417.6	328.1	287.1	255.2	229.7	191.4	164.1	153.1	143.6	127.6	120.8	114.8	104.4	95.7	
1/2	.5	.25	666.6	545.4	428.5	375	333.3	300	250	214.3	200	187.5	166.7	157.8	150	136.4	125	
5/8	.625	.3906	1,041.6	852.2	669.6	585.9	520.8	468.7	390.6	334.8	312.5	293	260.4	246.7	234.4	213	195.3	
3/4	.75	.5625	1,500	1,227.2	964.2	843.8	750	675	562.5	482.1	450	421.9	375	355.2	337.5	306.8	281.3	

THIS TABLE IS BASED ON $P = \frac{18,000h^2}{6L}$

P = Total Maximum Allowable Load (lbs) per 1" length of steel support (Load concentrated at tip of angle or plate.)

18,000 = Maximum Allowable Bending Stress—(lb/in²) at point "A"

h = steel thickness—inches

L = cantilevered length—inches

This formula is derived from the flexure formula $f = \frac{Mc}{I}$, and does not consider shear stresses or combined stresses. The shear stresses resulting from the tabulated loads are negligible; therefore, shear stresses or combined stresses are not a factor in design for conditions covered by the table.

Deflections at the toe of the angle resulting from the tabulated loads are well within allowable limits to prevent load transfers to the stonework below, using recommended joint design.

Note: The allowable loads shown are based on loads uniformly distributed along the length of the angle/plate, and angles/plates uniformly and adequately attached to the building structure. This table should not be used for other conditions.

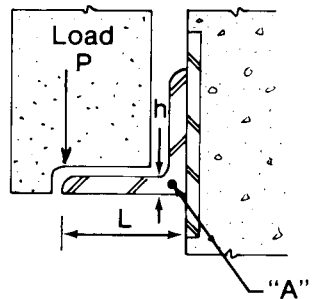
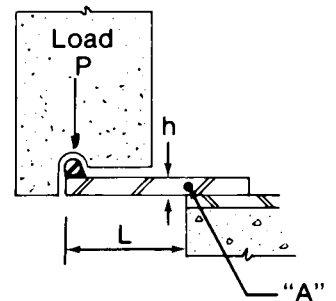

Note: Shims not shown for clarity.

support systems

“a” & “b” Supports Above Floor
 “c” & “d” Supports in Front of Floor
 “b” Supports Above Floor

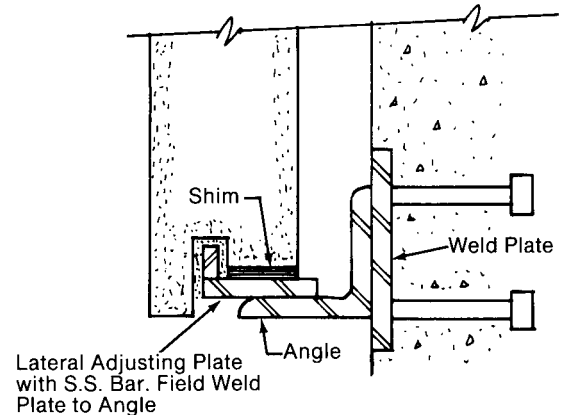
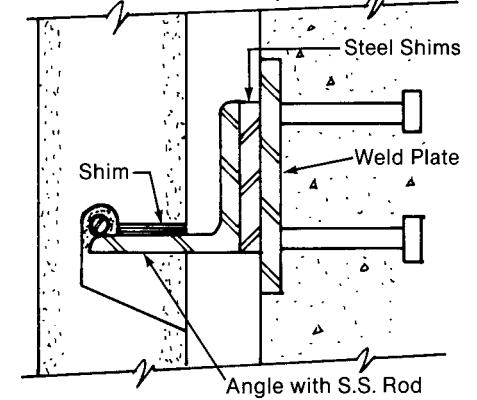
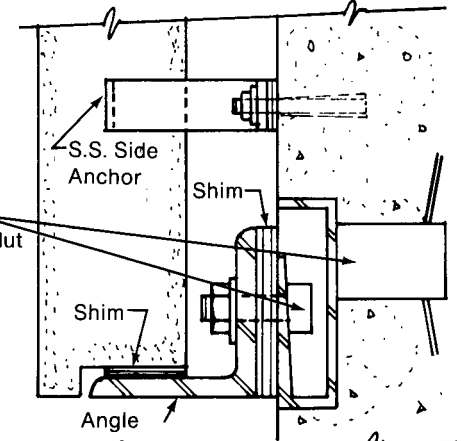
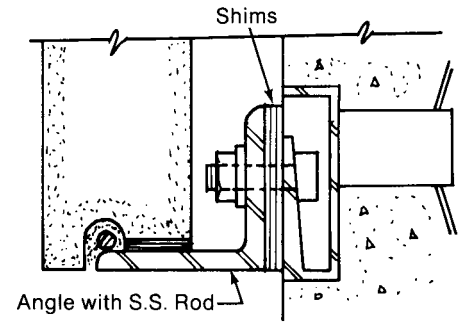
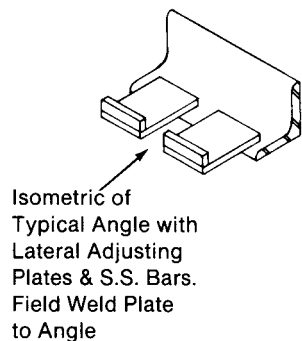
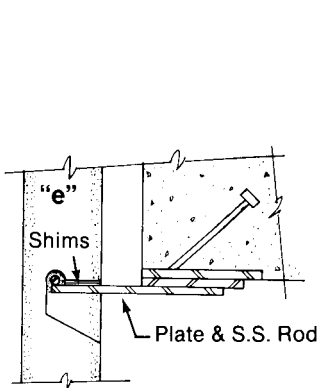
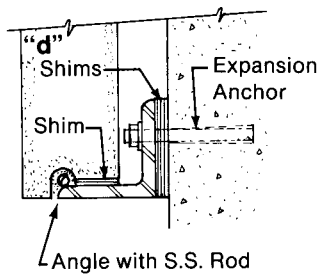
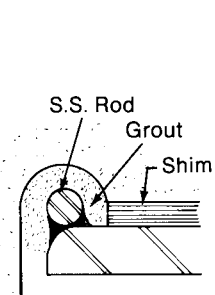
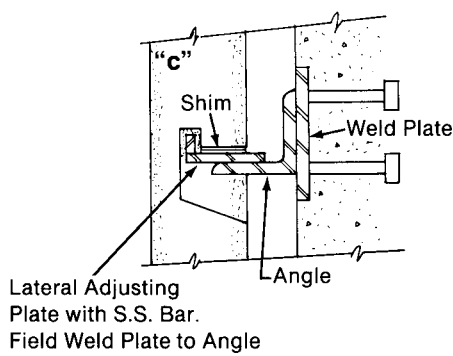
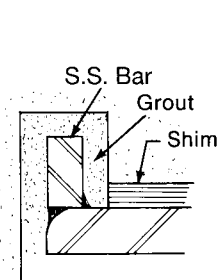
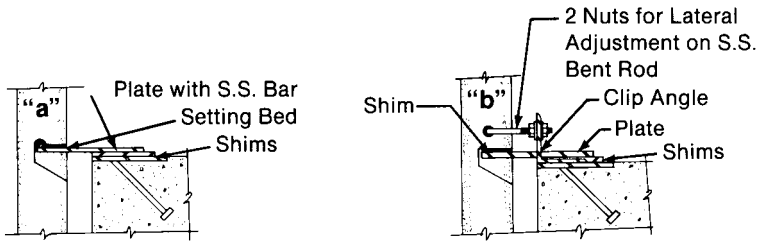

Note: The preferred location of gravity shelves is in the bottom bed or at least in the bottom 1/3 of the panel.

Note: Gravity support of panels directly on shelf angles or ledges is always preferred. However, in some cases liners may be required. Gravity support liners are critical elements, and should always be fabricated and designed by persons experienced and qualified for this type of work. See page 61 for additional information.

Note: Slip joints may be required in instances where floor deflection or other movement must be accommodated.

Note: Observe correct procedures in welding thin shim material to thicker weld plates.

Note: Where embeds for attaching support angles are required, they are to be located by the concrete fabricator or contractor. In general, metals for embeds should be compatible with the support angle metal for the stonework.

If flashing must be used in conditions similar to above, delete toe-bar or blade and install side anchor above flashing similar to “b” at left.

mortars

Portland cement used in preparing cement/lime mortar for setting Indiana Limestone should conform to the requirements of ASTM C-150. If masonry cement is used, it should conform to the requirements of ASTM C-91. Either material will produce a suitable mortar.

Mortars should be mixed to the proportion requirements of ASTM C270, Type N. Its compression resistance will approximate 750 psi when cured. This moderate strength is sufficient for most limestone installations.

Portland cement/lime mortars are mixed with one part cement, one part lime and six parts sand, all by volume. (Lime improves the workability of mortar, and helps to reduce shrinkage.) This 1/1/6 mixture provides sufficient compressive strength, good bond strength and good weather resistance. The qualities of mortar can be adjusted as needed for specific applications; ASTM specifications provide guidance for needs beyond ordinary installations.

Lime should conform to ASTM C-207.

Masonry cement, sometimes called "mortar mix" or "masonry mix," ordinarily does not require the addition of lime for shrinkage resistance or for improved workability. These qualities are derived from factory-added materials which usually include an additive for air-entrainment. Masonry cement is mixed with two and one-half to three parts of sand, also by volume.

Masonry cements may be obtained which will develop the qualities described by specific ASTM indices; as in portland cement-and-lime mortars, type N for masonry cement mortars is the standard for limestone installations.

Specifiers should be aware of unresolved conflicts between proponents of masonry cement mortars and portland cement/lime mortars. Questions about durability and bond strength needed in specific applications should be referred to cement companies or other authorities.

Low-alkali cement mortars will tend to be non-staining, although low alkali content in mortar used to set stone is not in and of itself a guarantee of such performance. Good masonry practice, especially the protection of stone backs from moisture sources, is the best prevention of stain. It should be noted that white cement is not necessarily non-staining. ASTM C91 describes non-staining cement; this type should be used with Indiana Limestone. ILI will comment to interested inquirers.

Sand should be clean and sharp and washed free of loam, silt and vegetable matter. Grading should be from fine to coarse complying with ASTM C144. If the setting mortar is to be the pointing mortar, white sand should be used.

Mixing water should be of potable quality.

Thorough mixing is necessary to develop the potentially desirable properties of mortar. Mortar should be mixed for a five-minute period after all materials are in the mechanical mixer.

The Portland Cement Association (PCA) recommends that mortar be retempered as often as is needed to keep the mortar as moist and as workable as possible. Mortar not used within two hours of initial mixing should be discarded.

As setting proceeds, the mason should remove mortar tags from joint edges after they have taken their initial set. Avoid smearing mortar and pointing mortar; smeared mortar can be difficult to remove. It may be desirable to use a mortar-bag in pointing vertical joints particularly, where pointing mortar cannot be easily scraped off a mortarboard. Final cleaning should be done with fiber brushes and detergents or mild soap powder. USE NO ACIDS. See page 38.

The relative stiffness of the mixed mortar is a matter of individual preference by the mason. In general, a mortar mixed to a "buttery" consistency will contain the proper amount of water. However, some masons prefer a stiffer mixture for setting stone than would be ordinarily used in setting brick or block. Stiff mortar may be helpful in setting particularly heavy stones.

Either mortar or joint sealant may be used to fill anchor holes. Lead wool is another alternative; shim stock of a non-corrosive material may be used provided it is not built up beyond a "snug" thickness.

Never use expanding type grout or mortar. Certain types of packaged grouts expand during the hardening period. When used in anchor slots and holes, this expansion can create sufficient pressure to fracture the stone at the anchor locations. Likewise never mix quick-setting compounds such as Plaster of Paris into the mortar mix; this will also create serious expansion pressure.

When cleaning finished walls built with brick and limestone, the contractor must use more than ordinary care to protect limestone from the acid used in brick-cleaning chemicals. This caution is even more urgent if colored mortars are used. See comments on CLEANING, p. 38.

When using colored mortars, samples of properly mixed mortar should be tested on limestone for assurance that they will not bleed into the stone. Wetted joint surfaces will help avoid this problem in any mortar system, but it can be especially helpful when colored mortars are used.

When mortars are transported, the containers should be pre-wetted and covered to prevent evaporation. Stored sand should be covered to maintain proper moisture content and to prevent contamination by leaves, trash, etc.

Mortar systems may be used in conjunction with sealant systems provided a joint tape is installed over the cured, raked-back mortar. Systems of this kind share the ability of mortar to carry loads and the superior durability of sealants. However, they also share the inability of mortar systems to absorb much joint movement, especially when stone size reduces the ratio of joint area to total wall area. For this reason, thoughtful designers often require that joints at parapets, copings and other particularly sensitive areas be left open (unmortared) for later closing with sealants. See p. 25.

The 1/1/6 mix suggested here, or a prepared masonry mix, will provide good compressive strength (ability to support vertical loads), bond strength (ability to resist eccentric or lateral loads), and durability (weather resistance). In most Indiana Limestone applications, the qualities of these mortars will be sufficient. For the convenience of specifiers ILI reproduces here the chart

which accompanies ASTM's specification for mortars, C-270. That document outlines procedures for the production of mortars much stronger and much weaker than ordinarily used with Indiana Limestone.

**TABLE 1
Mortar Proportions by Volume**

Mortar Type	Parts by Volume of Portland Cement	Parts by Volume of Hydrated Lime	Aggregate Ratio (Measured in Damp, Loose Conditions)
M	1	1/4	Not less than 2 ¹ / ₄ and not more than 3 times the sum of the volumes of cement and lime used.
S	1	over 1/4 to 1/2	
N	1	over 1/2 to 1 ¹ / ₄	
O	1	over 1 ¹ / ₄ to 2 ¹ / ₂	

**TABLE 2
Property Specification Requirements**

Mortar Type	Average Compressive Strength at 28 Days, Min. psi (MPa)	Water Retention, min %	Air Content, max %
M	2500 (17.2)	75	12
S	1800 (12.4)	75	12
N	750 (5.2)	75	14
O	350 (2.4)	75	14

pointing

Pointing cut stone after setting, rather than full bed setting and finishing in one operation, reduces a condition which tends to produce spalling and leakage. Shrinkage of the mortar bed will allow some settling since the mortar bed hardens from the face in. If set and pointed in one operation, the settling, combined with the hardened mortar at the face, can set up stresses on the edge of the stone. For this reason, it is best to set the stone and rake out the mortar to a depth of 1/2" to 1 1/2" for pointing with mortar or sealant application at a later date.

By raking the joints to a depth of about 1/2" to 1 1/2" the pointing can be done in one, two, or three stages. This allows each stage to seal shrinkage cracks in the preceding stage and finally the concave tooled joint provides the maximum of protection against leakage. (See also Sealant Systems, p. 25.)

Pointing mortar should not be a strong mix. If a hard pointing mix is used, any movement of the building will place excessive stress on the edges of the stone to cause chipping or spalling at the joints. Pointing mortar should be composed of one (1) part non-staining cement, one (1) part hydrated lime, and six (6) parts clean white sand which pass a No. 16 sieve. Add only enough water to make the mix workable. Pointing mortar can also be one (1) part non-staining cement, one and one-half (1 1/2) parts lime putty and six (6) parts clean white sand. (Lime putty usually is made up of lump lime reduced to a paste by thorough and complete slaking with cold water and screening through a 3/16" mesh screen into a settling box not less than one week before use.)

Mortar colors should be lime-proof and alkali-proof mineral oxides. Use the amount of coloring necessary to

obtain the color desired, but not more than 15% by weight of the cement. Carbon black should not exceed 3% by weight. To reduce shrinkage in pointing mortar, mix by adding just enough water to make a damp mixture. This semi-dry mixture is then left untouched for one to two hours. It is then remixed and water is added to obtain the desired plasticity and workability.

To improve the bond between the mortar and the stone units, use proper tooling to compact the mortar against the sides of the stone. A concave joint is recommended—using a tool larger than the joint. This is not a remedy for incomplete filling of the joints. Workmanship is the most important factor in obtaining impervious joints.

cold weather setting

The bond strength of mortar is considerably reduced when mortar is frozen prior to hardening. The chemical reaction between water and cement (hydration) progresses very slowly below 40 degrees F. Protection is necessary if the outside air temperature is 40 degrees and falling.

Admixtures or anti-freezes should not be used to lower the freezing point of mortar. The effectiveness of most

of these compounds is due to the calcium chloride they contain acting as accelerators.

Calcium chloride cannot be used on limestone. Salts cause efflorescence and may cause spalling or flaking through recrystallization (crystal growth).

Heating all materials must be considered. Sand contains some moisture that will form ice when stored in freezing temperatures and must be heated to thaw the ice. Sand must be heated slowly to prevent scorching. Mixing water should not be above 160 degrees F to prevent the danger of flash set with cement. The mortars should be between 40 and 120 degrees F when used.

Stone should be covered with tarpaulin, felt paper, or polyethylene, and heating units used to warm the stone. Caution must be used to prevent smoke under the covering from salamanders.

Never set stone on a snow or ice-covered bed. Bond cannot develop between the mortar bed and frozen supporting surfaces.

If stone is to be set during cold weather the cold weather masonry construction recommendations of the International Masonry Industry All-weather Council should be followed.

COLD WEATHER MASONRY CONSTRUCTION AND PROTECTION RECOMMENDATIONS

by the INTERNATIONAL MASONRY INDUSTRY ALL-WEATHER COUNCIL

The consensus of this Council regarding recommendations for cold weather masonry construction and protection is as follows:

WORK DAY TEMPERATURE	CONSTRUCTION REQUIREMENT	PROTECTION EQUIPMENT
Above 40 F	Normal masonry procedure	<i>Cover walls with plastic or canvas at end of work day to prevent water entering masonry.</i>
40 F - 32 F	Heat mixing water to produce mortar temperatures between 40 F - 120 F.	<i>Cover walls and materials to prevent wetting and freezing. Covers should be plastic or canvas.</i>
32 F - 25 F	Heat mixing water and sand to produce mortar temperatures between 40 F-120 F.	<i>With wind velocities over 15 mph provide wind-breaks during the work day and cover walls and materials at the end of the work day to prevent wetting and freezing. Maintain masonry above freezing for 16 hours using auxiliary heat or insulated blankets.</i>
25 F - 20 F	Mortar on boards should be maintained above 40 F.	<i>Provide enclosures and supply sufficient heat to maintain masonry enclosure above 32 F for 24 hours.</i>
20 F - 0 F and below	Heat mixing water and sand to produce mortar temperatures between 40 F - 120 F.	

sealant systems

Sealants must serve the same purpose as mortar and pointing in the exclusion of moisture. The most commonly used one-part systems are called “moisture-cure” or “air-cure.” Two-part systems depend on a catalyst or chemical agent to cure. Curing may be considered analogous to the “setting” of mortar, but sealants are not intended to bear weight and thus must be handled differently in the construction process.

The materials of a sealant system consist of a sealant backer or stop, usually a foam rope or rod placed in the joint to a predetermined depth, and the sealant itself, which is gunned in against the stop. Some systems require a primer which must be applied to the joint’s inner surfaces in advance of the sealant to assure its adhesion.

In general, the sealant should not adhere to the backer rod. Joints utilizing a sealant system work best when the sealant is required to adhere to parallel surfaces only; especially in the wider joints, omission of a bond-breaking stop may contribute to failure.

Mortar setting systems may be used in combination with sealant systems if the setting mortar is raked back sufficiently far to admit the backer rod or rope and the proper thickness of sealant. Or, the weight of the stone on its bearing surfaces may be supported by a sufficient area of setting pads such as lead shims or plastic pads in lieu of mortar. ILI will comment to interested inquirers.

Manufacturers of sealant systems are the best source of information on system types and accessories. ILI works with many of them to assure the availability of up-to-date information. The following section on joint movement is a good general guide to joint sealant design. A specification for sealant systems is contained in the “specifications” section.

JOINT SEALANT DESIGN

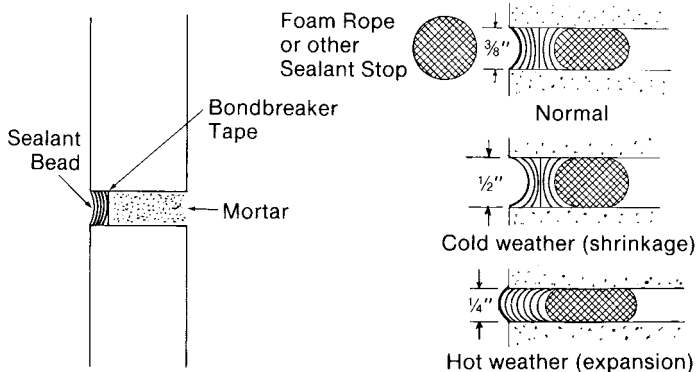

Note: Shims may be substituted in sufficient area to support the load.

attachment to steel or wood studs

Stud backup systems are acceptable with Indiana Limestone wall facing provided that (1) no gravity loads are transferred to the stud system, (2) the stud system is strong enough to resist the lateral load design, and (3) the anchor system is sufficiently stiff to uniformly pass expected lateral load to the stud system.

A frequent question is about allowable or recommended deflection of stud back-up walls for stone cladding. For masonry cladding set in mortar, most authorities recommend that deflection be limited to L/600 to L/720 or stiffer to minimize damage to the mortar joints and resulting leakage. If stone is set with resilient setting pads and with sealant joints, more deflection may be acceptable. It should be noted that excessive deflection may induce localized prying action at embedded anchor locations.

Both steel and wood studs can be designed sufficiently stiff to support horizontal wind loads. However, both stud types have limitations which should be considered at the design stage.

Steel studs are typically installed using self-tapping screws. These screws are typically engaged only by one or two threads in the stud flange and may lose much of their capacity if over-torqued. Corrosion due to moisture in the wall cavity may also reduce screw capacity and stud strength. These and other problems with self-tapping screws have led to failures. ILIA RECOMMENDS AGAINST THE USE OF SELF-TAPPING SCREWS FOR ATTACHMENT OF STONE ANCHORS TO STEEL STUDS. Some other considerations when designing with steel studs should include deflection criteria, locations of studs with respect to required locations of stone anchors, the possible need for added members to receive stone anchors, the effect of concentrated loads, the effect of the fasteners themselves, the effect of sheathing on anchor capacity and attachment methods, and the types and sizes of fasteners required.

Wood studs may shrink, causing anchor misalignment over long periods. Wood studs will lose strength if deterioration occurs due to rot or insect damage.

The weight of the stone (gravity loads) should not be carried on studs. These loads should be carried on the building foundation or structural frame using appropriate steel connections.

Recommended details are shown on page 26.

A horizontal structural member $\text{\textcircled{D}}$, similar to that shown in the illustration, is required as shown at each bed joint

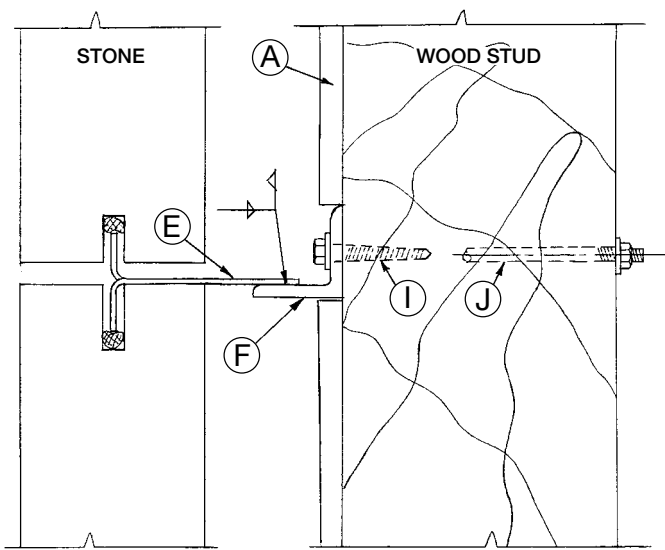

PREFERRED

WOOD STUDS

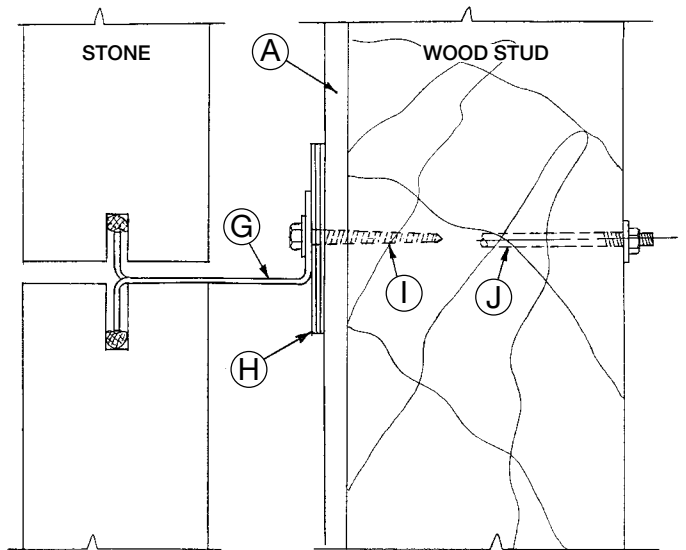

OPTIONAL

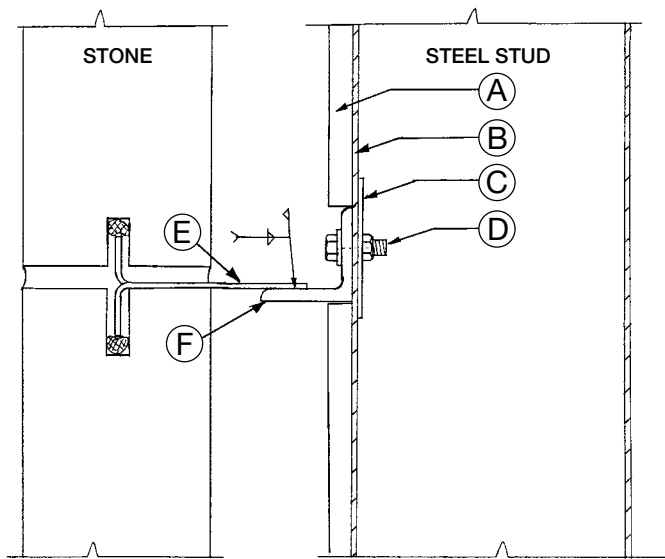

PREFERRED

STEEL STUDS

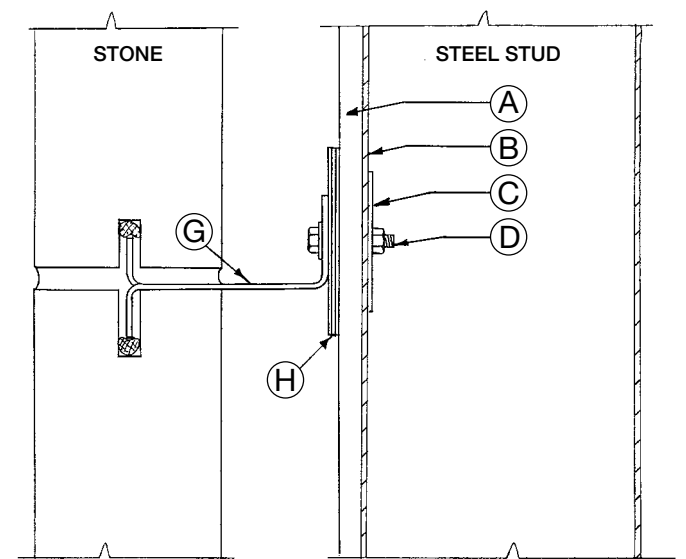

OPTIONAL

- A Exterior sheathing
- B Flange of steel stud
- C Plate washer
- D $\frac{3}{8}$ " diameter bolt—A307 steel
- E Wind anchor—stainless steel. Two per stone minimum—top and bottom bed.
- F Continuous angle bolted to every stud
- G Wind anchor—stainless steel—bolted to every stud. This method requires either a continuous slot in the stone or anchor slots cut in the field to match the stud locations.

- H Shims if required. Shims may be omitted if anchor is bent to fit in the field and bolted direct to the stud—not to the sheathing. Shims should be large enough to distribute the load on the sheathing. If the load is heavy enough to crush the sheathing, the shims should be bolted direct to the stud—not to the sheathing.
- I Lag screw—size as required but not less than $\frac{5}{16}$ " diameter x 2" long.
- J Thru bolt may be used instead of lag screws for heavier loads.

Note—ILLI provides standard details for the user's information and convenience, and does not perform engineering calculations

to transfer anchor load into the studs. Two design issues must be resolved. First, the stud locations are not normally predetermined; therefore this member is used as a beam to carry loads to stud or studs not in the anchor plane. Secondly, if anchor spacing is greater than stud spacing, the horizontal member should be sufficiently stiff to distribute the loads into the studs uniformly.

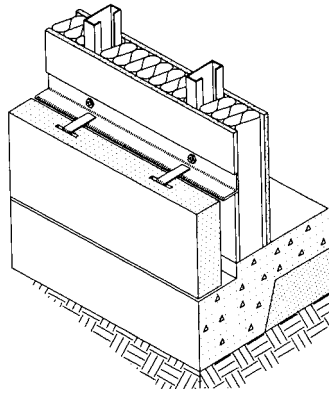

The optional method shown requires an anchor at every stud. This requires stone of sufficient length to span across at least two studs. For additional information, see the ILI Technote on Wood and Steel Stud Construction on page 146.

joint movement

Indiana Limestone has a low coefficient of expansion (2.8×10^{-6}) which means that a 100 ft. long wall exposed to a temperature variance of 130 degrees will move $7/16$ ". Seven (7) $1/4$ " expansion joints can be incorporated into this wall, allowing $1/16$ " movement of each $1/4$ " joint. If the percent of elongation and compression

capabilities of the sealant selected is 25%, the joint design and percent of movement are within the 25% maximum movement recommendations for a joint. (See p. 25.) The size of the joint should be adjusted to the elongation limits of the sealant. A sealant with a 15% joint movement capability would require a $7/16$ " joint size to withstand a $1/16$ " joint movement.

These examples assume that movement will be equally distributed over all joints. By sizing the joints larger than minimum design requires, a safety factor can be obtained to accommodate atypical movement.

expansion joints and control joints

In exterior limestone walls, expansion joints or control joints should be provided to prevent or reduce damaging effects of thermal expansion and other dimensional changes of the building frame, back-up walls or other building elements and components. It is standard practice for the Project Architect or Project Engineer to size and locate these special joints.

Control joints as discussed here are typically standard or near-standard size joints in the stone cladding that will permit small amounts of differential movement. In concrete or CMU they are typically intended to handle shrinkage that commonly occurs in those materials.

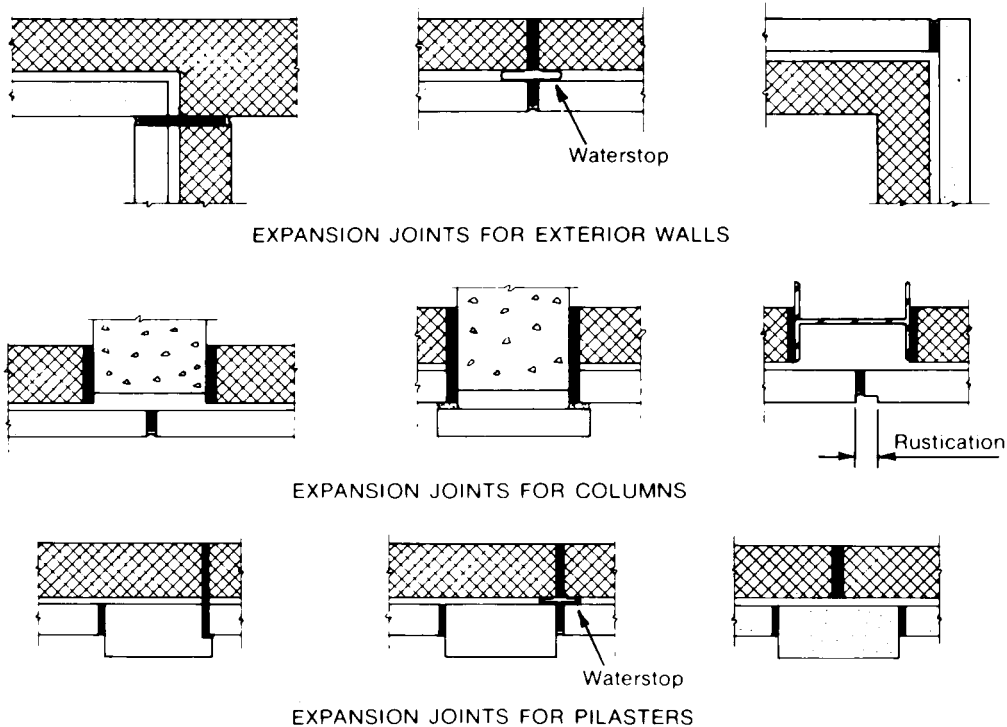

FIG. 19

Expansion joints are usually larger joints—usually 1" or more in width—that permit larger amounts of movement. These usually correspond to similar joints in the main structure.

Joints in the stone cladding should correspond with similar joints in the back-up walls and in the primary frame of the building.

Control joints and expansion joints are usually vertical. Stepped joints are possible but are more complex and are not preferred. Horizontal expansion joints in the stone cladding are usually referred to as relief joints or pressure-relief joints. These are discussed in the next section. Control joints are usually finished with backer rod and sealant. The width of the joint should be based on the anticipated movement and on the width of sealant required to handle that movement.

Expansion joints normally consist of a pre-molded filler and sealant compound. The pre-molded filler should be compressible to the amount of movement calculated with resiliency to return to its original shape. The sealant compound should be completely elastic and provide lasting adhesion to the surfaces separated.

The best location for an expansion joint is in an offset of a building when one occurs, or, at the junctions of the sections comprising a "U," "T," or "L" shaped building. If the expansion joint is straight up a facade, the required width may cause it to show. This can be minimized by increasing the number of expansion joints and maintaining their width to match the other joints in the building.

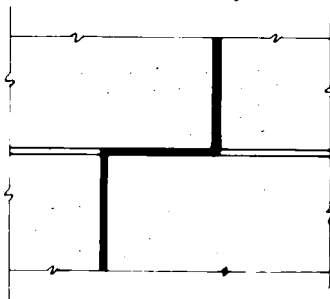

VERTICAL EXPANSION JOINT WITH HORIZONTAL OFFSET

FIG. 20

The coefficient of thermal expansion of concrete and steel supporting structures is typically much greater than that of limestone. Differential movement between the building frame and limestone cladding causes such problems as pushing out of header stones at corners, the fracturing or spalling of stone at joints, and failure of the stone or the anchor itself at anchor locations. Stonework erected in cold weather may develop temperature stress in joints in warm weather.

The expansion calculations for modern structures are normally based on the coefficient of expansion of the frame or supporting members rather than the stone. The result will determine the maximum movement. The thermal expansion and contraction is equal to:

$$\Delta L = aL \times \Delta t$$

ΔL = change in length – inches
 a = coefficient of expansion – in/in/degree F
 L = overall length – inches
 Δt = temperature change – degrees F

For example, if a stone wall 100 feet long is heated from 0 degrees F to 130 degrees F, the increase in wall length will be $.0000028 \times (100) (12) (130) = .436$ inches = $7/16"$. The expansion of the steel building frame, assuming the same temperature change, would be $13/64"$, and for a concrete frame it would be about the same, depending on the type of concrete.

This expansion difference is an extreme example and would apply only in such uses where stone-covered members are exposed on all four sides. Usually, the building frame will be subjected to less temperature variation than the skin of the building. Assuming a 130 degree F change in the stone wall, and a 100 degree F change in the steel frame, the differential expansion between stone and steel would be $3/8"$ in 100 feet. This requires the installation of joints capable of handling this difference in thermal movement.

Another important reason for expansion-control joints is the difference in thermal and moisture coefficients of expansion between stone cladding, back-up materials and other building elements which may abut the stone cladding. For instance, concrete block—a common back-up material—typically shrinks as it dries. Other materials which back up or abut the stone may expand with time or temperature. Expansion-control joints should be specified, located and sized to accommodate these differential movements without a build-up of excessive stress.

These differential coefficients and volume changes may impose load on the stone anchors as well as on the stone. For this reason, in addition to the expansion joints, it is advisable to design a certain amount of flexibility into the anchoring. To some extent, and in some cases, this can be accomplished by maintaining at least a 2" space between the back-up and the stone to allow some movement in the anchors. It is also advisable to coordinate and match as closely as possible the location of expansion joints in the exterior cladding with such joints in the back-up walls.

Examples where expansion-control should be considered are shown throughout this section.

Thoughtful design will avoid potential damage where heaving concrete slabs might create eccentric pressures. The lateral projection of either base courses or ashlar panels over grade slabs should be avoided in unstable soil conditions.

Figure 23 shows an expansion joint between steps and the cheekwall and also around the handrail post where the post goes through the stone into the concrete base.

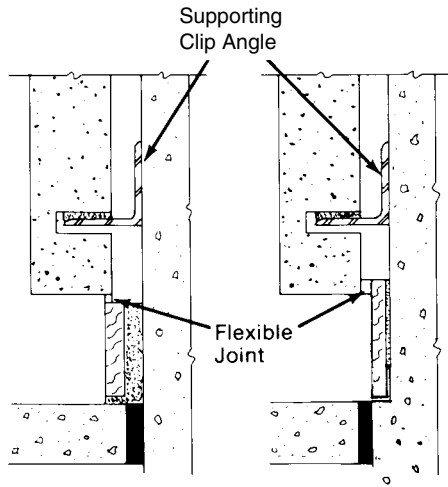

RECOMMENDED
FIG. 21

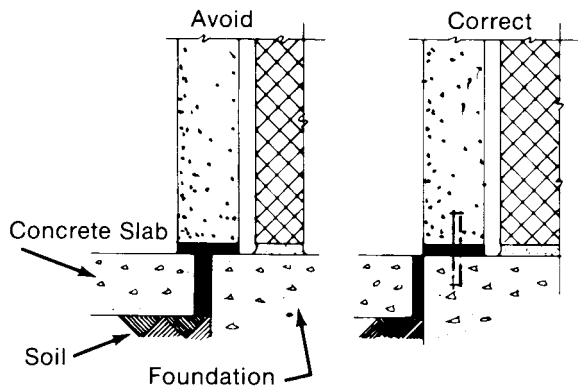

EXPANSION JOINT OVER CONCRETE SLAB
FIG. 22

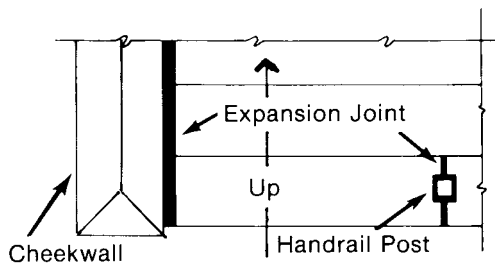

EXPANSION JOINT AT STAIR
ENDS AND HANDRAIL POSTS
FIG. 23

Figure 24 shows a one-inch space between stone and the spandrel beam or floor slab. Too often the expansion of the beam will push stones out at corners on non-load-bearing walls with no expansion space provided.

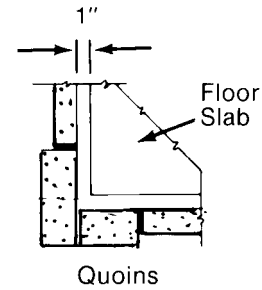

MAINTAIN SPACE
BETWEEN STONE AND
SPANDREL BEAM

FIG. 24

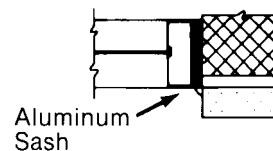

EXPANSION JOINT
AT ALUMINUM
WINDOWS

FIG. 25

pressure-relieving joints

Shelf or clip angle support systems should be designed to accommodate expansion of stone due to thermal movement, contraction of the main building frame due to temperature, shrinkage or creep, to accommodate potential live-load deflections, and to avoid build-up of stresses due to these and other normal building movements. Also, installation of pressure-relieving joints at periodic intervals helps assure that bearing stresses of the stone on its supports remains within acceptable limits.

Typically, these pressure-relieving joints (often called relief joints) should be matched with similar pressure-relief joints in the back-up structure. Such joints are usually located at or near floor lines or the bottom of floor beams.

A pressure-relieving joint should be placed under each clip or shelf angle or under the bottom bed of a panel

supported by clips in pockets. This is accomplished in either mortar or sealant systems by leaving a properly sized horizontal joint space between the top of the stone below and the bottom of the stone above. Typically these are sealant joints. Such relief joints must be sized for anticipated vertical movement and, if sealant-filled, must also consider the ability of the sealant to handle movement. They must be free of shims, pads or mortar or any other material that would interfere with their function. Dowel or other anchor holes or slots in such systems should have compressible material placed at their bottom and/or top as well.

As a general statement, installation of compressible material at the bottom and/or top of anchorage holes and slots will minimize the risk of high stress concentrations and potential stress failures in the stone at anchorage points.

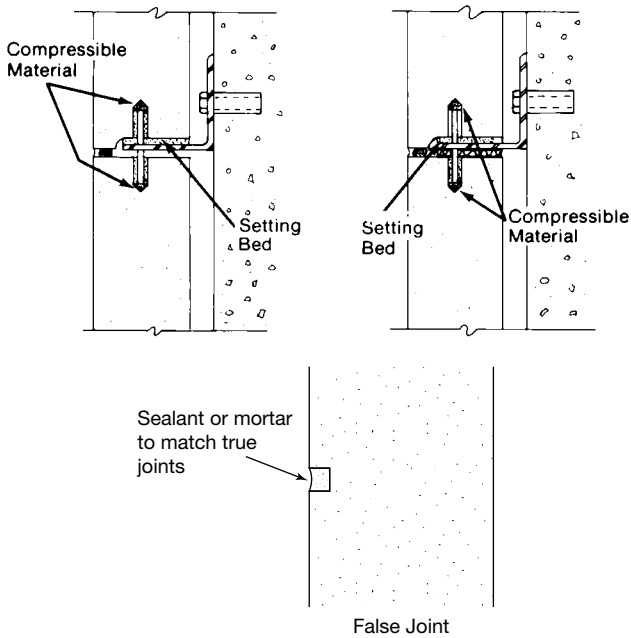

FIG. 26

false joints

When design requires a false joint in dimensioned stone, it should be cut the same width as the bed joints. If not pointed or sealed, false joints will not match the other joints. False joints reduce the effective thickness of the stone for handling and wind load purposes.

dampproofing

UNEXPOSED SURFACES

“Dampproofing” is the common term describing the various coatings and membranes used to control construction moisture and ground water. Proper attention to

dampproofing procedures in Indiana Limestone construction will eliminate many cosmetic problems during and immediately after construction.

A continuing supply of water or moisture will not harm or discolor Indiana Limestone unless it carries with it a high alkalinity or soluble salts. Portland cement, concrete blocks and other cement products contain such alkalinity. It is important to isolate the stone from sources of alkaline solutions such as wash from concrete pours, untopped concrete block walls, unglazed window openings and the like.

Where Indiana Limestone is used at grade, or where supported on concrete ledges or haunches, or on continuous angles, a back-coating of either cementitious waterproof stonebacking or bituminous stonebacking should be used. This material may be placed on the stone prior to setting; however, the cementitious material must cure to become effective. The bituminous coatings often are difficult to apply cleanly, and will retard mortar adherence.

The stonebacking material should be applied to all unexposed surfaces of the stone up to 1'-0" above grade including joints. In those cases where stone is carried below grade, the covered portion of the face should also be coated. Below-grade mortar joints should be similarly treated.

Although coating the support surfaces is generally less effective, the same materials may be used on angles, concrete ledges and other bearing surfaces.

Figures 27A, B & C illustrate the placement of these coatings. Note that the intent of the coating is to isolate the stone from both high alkalinity and from soluble salts. Therefore, attention should be given to such conditions in design, and proper type and placement of coatings should be specified. These coatings should be applied in the field, to assure their undamaged condition.

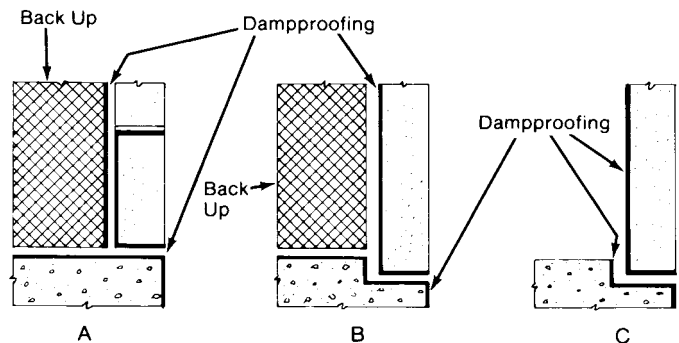
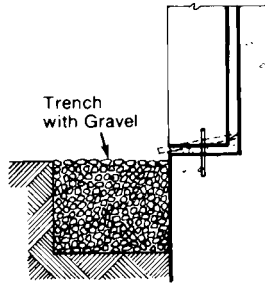

FIG. 27

The conditions shown here illustrate the procedure for isolating Indiana Limestone from the possible harmful effects of ground and construction moisture. Weepholes, moisture barriers and thoughtful design will avoid most potential problem areas. The dark lines shown throughout these illustrations represent either waterproof cementitious stonebacking or asphaltic emulsion paint. See comments on the relative merits of each material and suggestions for their use in DAMP-PROOFING.

--- Path of Moisture through Stone
 ——— Heavy lines indicate dampproofing



Trench with Gravel
 A gravel-filled trench will help prevent soil splash.

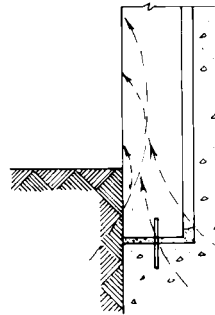

Drain or Slope Trench

Where stone is exposed below grade it MUST be protected.

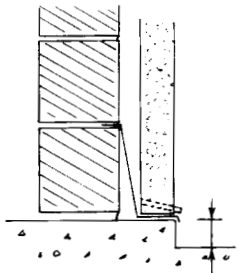

Weep Tube or Felt Wick
 Weep continuous and other angle supports where moisture collects.

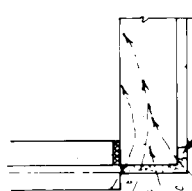

Trapped Moisture

Keep stone above grade where design permits.

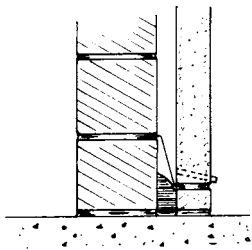
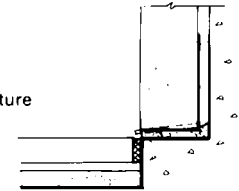

1" Airspace
 Air spaces isolate stone backs from moisture.

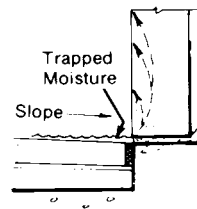

Trapped Moisture
 Slope

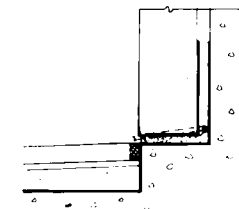

Note: Isolate stone from grade moisture with a concrete ledge or a dampproofed starter course with flashing as shown.

Note: Indiana Limestone paving must be properly sloped for good surface drainage; avoid low spots where surface moisture can collect. See p. 63.

Stain resulting from alkalinity will usually disappear within a few months after completion of construction, when sources of moisture may be expected to dry up. Ground moisture usually may be expected to continue for the life of the building, and any stain from that source is likely to be long-lasting.

water repellents

Exterior water repellents intended for application to vertical, above-grade, masonry walls are, generally, clear liquids of low viscosity. Their chemical makeup allows them to be absorbed by masonry substrates, leaving the surface essentially unchanged in color or texture. The active ingredients in water repellents are intended to be deposited in the pores of the substrate while not closing or blocking them, so that moisture

vapor can pass from within the wall, but liquid moisture is not absorbed at the surface. Water repellents should reduce the adherence of dirt to building walls because they render the wall less absorptive. They should reduce or eliminate a "wet look" in rainy weather. They should reduce humidity in cavity walls. An effective water repellent will create these effects without altering the color of the substrate, and without creating a shine, or sheen.

In common usage, water repellents are sometimes called sealers, or waterproofers, or dampproofers. These misnomers are confusing; worse, they tend to instill a false sense of security in users. Water repellents will not render a wall waterproof, nor will they "seal" it. Waterproofers or sealers are by definition coat-formers; they change the color and texture of the substrate. Ideally, a masonry wall treated with a water repel-

lent should not differ in appearance, during dry weather, from a similar, untreated wall.

Water repellents are not waterproof. They will not bridge gaps in mortar or sealant joints. Their use is not a fail-safe for poor mortar practice, nor a substitute for damp-proofing. Water repellents have been suspected of contributing to surface scaling in some cases. It is possible that a water repellent allowing vapor transmission may reduce the *rate* of transmission compared to identical, untreated, substrates.

Water repellents should be applied only on completed walls, with mortar or sealant joints in place. They should not be applied over wet or stained stones, nor to stone backs, nor stones under grade.

Good workmanship is essential in the application of water repellents. As a class, the materials tend to be labor-sensitive; substrate condition, weather condition, application tool, flow rate, etc., should all be in accordance with manufacturers' instructions.

ILI does not recommend specific types or brands of water repellents. Product types including silicones, stearates, acrylics, silanes, and siloxanes have all been used with apparent success on Indiana Limestone. ILI does recommend that (1) stone samples be treated on only one-half their surface for initial evaluation; (2) manufacturers provide statements on both vapor transmission and guarantee; and (3) applicator and manufacturer agree on the condition of the wall and the weather prior to application.

An understanding of probable retreatment costs, probable length of time until retreatment may be needed, and alternatives to retreatment should be part of the consideration of water repellents.

ILI will respond to requests for further information on this subject.

GRAFFITI REPELLENTS. Graffiti materials include pencil, lipstick, felt-tip pen, spray paints, enamels, and lacquers. Each requires its own type of removal process and materials. The only general rule is that prompt cleanup will be the most successful. Specific recommendations for removal are given in other ILI publications.

Graffiti-proof coatings should not be confused with water repellent materials mentioned earlier. Successful coatings tend to be slick or shiny. They offer no "tooth" to which graffiti materials may cling. The coatings also tend to retard the wall's ability to breathe. Therefore, their use should be limited to those areas subject to graffiti—generally within about eight feet of grade.

These coatings may change the color of the stone by altering the refractive qualities of its surface; thus, they may become a design consideration. Application should be terminated at joints or other natural stops. Some coatings are fragile and easily scratched when damp.

flooring and paving with indiana limestone

As suggested in Note C, Table II, Indiana Limestone can perform satisfactorily as a flooring and paving material. Surface wear due to insufficient abrasion resistance in the stone is seldom a cause of problems with paving except in high-traffic, bottleneck areas. Because bending failure is not a factor in most flooring applications, thickness decisions can be made based on other factors. ILI or its member companies should be consulted on available thickness.

For exteriors, Indiana Limestone will give the most satisfactory performance when no moisture can rise through it from grade, mortar bed or concrete base. In practice, isolating the stone from this "rising damp" can be done by dampproofing ALL unexposed surfaces. (See pp. 30 and 63.) Thereafter, the stone can be set as usual.

Isolation can be achieved also by the use of setting mats or pedestals. Either system allows moisture to move below the stone's lower face, along the concrete base to properly located drains. For greatest efficiency, these systems are set with open joints, or butt joints, which allow for continuous drainage.

In any setting system, drainage of surface water is of the greatest importance. Especially in frost areas, slope and crown must be properly designed and built, and water must be channeled away from the paving. In mat and pedestal designs, subsurface drains must be kept free-flowing and clear of debris.

Exterior stone will not usually need a sealer or other protective treatment on its upper surface. Allowing the stone to acquire its natural patina with age is usually a better decision than to apply a temporary coating. These products will usually either darken the stone, or cause it to shine, or both. They may increase slipperiness as well.

Limestone used as interior flooring must usually be applied on a mortar bed. "Thin-set" mastic can also be used provided the concrete base is very flat and level. Bituminous mastics will usually not bleed or "telegraph" through limestone. Test applications are recommended.

For flooring projects utilizing Indiana Limestone, the specified substrate must be sufficiently stiff to eliminate stone bending. If the floor deflects, consider the use of smaller stones. Wood sub-floors, for example, will not usually provide the rigidity needed for a good limestone installation, especially if a thickness less than 2" is chosen. Depending on the deflection expected, smaller sizes may be stiff enough to resist cracking, although mortar in these conditions may crack.

The dampproofing treatment suggested for exterior paving is a good idea for interior flooring as well, especially if a wet mortar bed is to be used. Dampproofing will help eliminate alkali stain. Interior stone so stained is difficult to clean.

Joints in interior stone floors are typically grouted. Grout must be carefully placed to avoid smearing. A grout bag or mortar gun is the recommended tool for placement. Do not remove mortar "tags" until set. Do not "bag" or wet-tool stone joints. Paving expansion is similar to expansion in walls; thus, expansion joints should be provided at perimeter walls as well as in a grid of intermediate joints spaced every 25 feet or so, as otherwise appropriate.

Sealers for interior stone floors may tend either to change the stone's color, or cause it to shine. Stone should be sampled with the chosen sealer before work proceeds. Sealers should resist all kinds of household stains, and they should be easily cleanable using ordinary tools and materials.

reglets

Caps and copings are often eliminated in those designs requiring an uninterrupted line at the building's parapet. Where this condition exists, reglets may be cut into the stones' tops or backs to accept and hold flashing. Reglets can be cut into the stone vertically, horizontally or at any angle.

Reglets from 3/8" to 1/2" wide by 3/4" to 1" in depth are standard. The metal cap-flashing should be securely fastened in the reglet with soft lead or crimped sheet metal wedges spaced about 12" apart, or with lead wool; either method requires a final pointing with a permanent sealant compound.

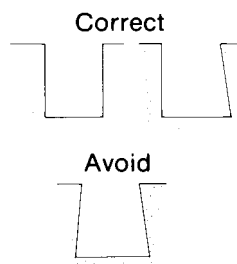

For production economy, avoid splaying both sides of the reglet; at least one side should be straight.

Wood wedges should never be used to secure sheet metal flashings in reglets. They will absorb mois-

ture, swell, and can split the stone, especially where the reglet is close to the edge. Reglets should not be closer than 2" from the edge of the stone.

flashing and metalwork

Throughout this publication, we illustrate sections where flashing may be required. Because this item is not specific to limestone, and because flashing uses vary with place and condition, we have opted not to show flashing in our publication. Omission of flashing in our section illustrations should not be taken as ILLI's position on the subject. The best information on flashing use and practice comes from manufacturers and their representatives.

Flashings of stainless steel, lead, zinc, aluminum, copper, lead-coated copper, and certain plastic materials may all be used satisfactorily with Indiana Limestone. Copper and aluminum may cause stains and discoloration if water is permitted to wash from them over the face of the stone. In general, wash water back onto the roof rather than over the stone. Stainless steel flashing can be expected to have a long life, but like other metal materials, it can be difficult to form and join. PVC flashing materials can be joined without large seams. However, they tend to have poor UV resistance. This class of flashing is easy to place over support steel such as clips and continuous angles, and in stone pockets where needed. The relative thermal expansion of metal flashing to stone may vary from two to ten times. This fact may cause premature failure of sealant at flashing joints, especially when flashing lengths are much greater than stone widths. Therefore, prudent design of flashing conditions may require that stiff metal flashing material be cut to lengths approximating stone widths, and that joints occur at or near stone centerlines, away from stone joints. Wide, overlapping flashing joints will help eliminate failure due to thermal expansion as well.

Avoid creating small ledges of projecting flashing at stone backs. Ice forming at such ledges may cause sealant failure. Reglets must align well to assure a good watertight seal. Avoid the use of explosive-actuated fasteners for affixing flashing and counter-flashing to stone; non-corrosive screws or nails should be driven into small expansion shields in the stone for this purpose.

Brass, bronze, aluminum and mild steel ornamental features, signage, hangers and the like should be provided with drip elements and should be set a minimum of 1" away from stone faces. Anodized, lacquered and other impervious finishes usually cause fewer discoloration problems.

weeps and wicks

In general, weeps and wicks should be placed over horizontal water stops such as continuous support angles or concrete ledges, and over openings where lintel angles are used to support stones above. These moisture-escape systems are most useful when installed over flashing which directs moisture toward them. They are not designed to eliminate more moisture than is likely to accumulate as a result of condensation. Weep tubes and holes are the more efficient of the two types, but they have the disadvantage of plugging up with debris. Rot-proof felt wicks continue to work, even in the presence of debris, but they are less efficient. Conservative design dictates a greater number of them than of weep tubes or holes. Weep systems are counter-productive if installed under grade.

carving, ornament and sculpture

Indiana Limestone has a texture which provides shadow character more predominately than smooth dense materials. However, the design should be bold, and not depend on antiquing for detail.

Sculpture can be line carving, incised, relief, or free-standing. Line carving is a form of incised, in which the form is sunk into the stone. In relief, the form is slightly or greatly projected from the stone face.

Indiana Limestone suppliers can provide original designs, or models from photos or drawings. They can work from a client's models. In some cases, carved work can be accomplished using shaded drawings. If the client prefers, work can proceed based on models, full or scaled, provided by the stone supplier and approved by the architect. The architect should provide

ample detailing of the proposed carving on the bid drawings for the fabricator to accurately price.

inscriptions

Letters cut in limestone can be raised or recessed (commonly known as incised). Raised letters require that the background be cut away to leave letters projected. A textured finish is often used as the background to give emphasis to the smooth finished letters. Raised letters are fragile and subject to chipping at traffic levels. Also, they are not economical to produce. Incised letters can be "V" cut or "square" cut. Incised letters should be slightly deeper than the width of the bars. Sandblasted letters are cut to a "U" and have a pitted surface.

Minimum letter size should be 1" in height. Letter size, type of letter and depth of cut should be included in the information given on full size details.

Commercial preparations are available to darken letters for a shadow effect, or color can be used.

Gold leaf may be used and is usually permanent when properly done. The grooves must be sealed with a coat of spar varnish mixed with Japan drier. A chrome yellow pigment can be applied over the varnish to improve coverage. After drying, a second coat is applied and when tacky, 23K patent gold leaf is applied. Remove paper and burnish with cotton. These applications should be done on the jobsite. Do not use gold leaf on letters under 2" in height. Do not use bronze as a substitute for gold leaf as it will darken.

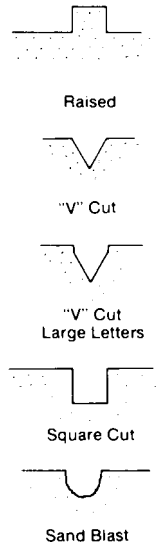
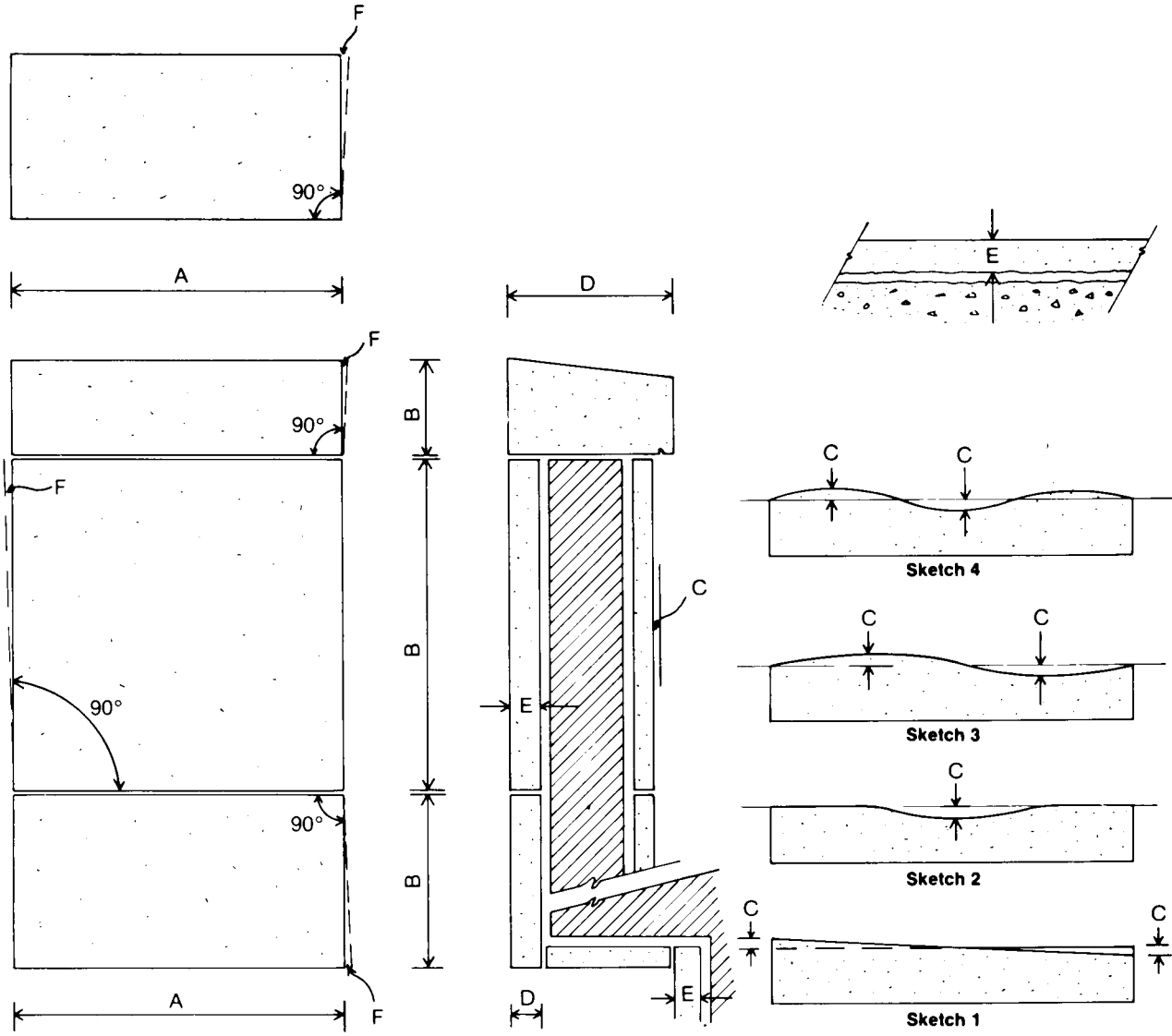

FIG. 29

fabrication tolerances for cut indiana limestone



DEVIATION FROM FLAT SURFACE

	A	B	C	D	E	F
	Length	Height	Deviation From Flat Surface Exposed Face	Critical Depth	Non-Critical Depth	Deviation From Square
Smooth Machine Finish	±1/16"	±1/16"	-1/16 to +1/16	±1/16"	±1/2"	±1/16"
Diamond Gang Finish	±1/16"	±1/16"	-1/4 to +1/4	±1/8"	±1/2"	±1/16"
Chat Sawed Finish	±1/16"	±1/16"	-1/4 to +1/4	±1/8"	±1/2"	±1/16"
Shot Sawed Finish	±1/16"	±1/16"	-1/2 to +1/2	±1/4"	±1/2"	±1/16"
Pre-Assembled Units	±1/8"	±1/8"	-1/8 to +1/8	±1/8"	±1/2"	±1/8"
Panels over 50 sq. ft.	±1/8"	±1/8"	-1/8 to +1/8	±1/8"	±1/2"	±1/8"

Tolerances C and F are measured within the length of a standard 4'-0" straightedge applied at any angle on the face of the stone.

Custom Finishes—Consult fabricator for texture variations, nominal thickness and jointing.

Note: In stones having one or more dimensions over 5'-0", and in many multiple-stone assemblies, tolerances larger than the above may be necessary. Determination of applicable tolerances will result from consultation with the stone fabricator by designers or engineers. Indiana Limestone tolerances are much smaller than those of most other materials. As a result, tolerance problems usually arise from ignorance or misuse of the tolerances allowable for other materials.

fabrication tolerances/definitions

A. Length	The overall horizontal dimension of an individual unit or stone as it is incorporated into the construction.
B. Height	The overall vertical dimension of an individual unit or stone as it is incorporated into the construction.
C. Deviation from Flat Surface Exposed Face	<p>A flat surface, by definition, is a surface in which, if any two points are taken, the straight line that joins them lies wholly in that surface. This definition, when applied to the fabrication of Diamond Gang Sawed, Chat Sawed and Shot Sawed finishes, limits the acceptable amount of “run out” or deviation of the gang saw blade used in the fabrication process.</p> <p>Some mills continue to use the gang saw to process the mill block into slabs. The gang saw is a frame across which are stretched steel blades, usually fitted with diamond teeth in matrix segments. Originally gang saws utilized coarse sand and sometimes steel shot as abrasive material. The comparatively rough surface produced by these methods was sometimes used as a finished surface; the finishes were called sand sawed, chat sawed, and shot sawed. Few mills use loose abrasives presently. Blocks may be sawed into slabs using circular diamond-toothed saws, wire saws, or belt saws. Usually slabs are either planed or ground to produce a plane, smooth surface.</p> <p>Diamond Gang Sawed, Chat Sawed, and Shot Sawed surface finishes are obtained in the gang saw process described above. No further machining can be done to flatten the surfaces because the surface finish would be destroyed. The tolerance “Deviation from Flat Surface” therefore becomes a gang sawing tolerance, or blade “run out” tolerance. Four examples of the application of this tolerance are shown in Sketch 1 thru Sketch 4.</p> <p>The “Smooth Finish” is obtained by planing or grinding the sawed slabs previously described. Thus, the deviation permissible is much less, as shown in the fabrication tolerance standards.</p>
D. Critical Depth	The required dimension of the stone from the finished face to the finished or semi-finished back of the stone as it is incorporated into the construction.
E. Non-Critical Depth	The required dimension of the stone from the finished face to the unfinished back of the stone as it is incorporated into the construction.
F. Deviation From Square Preassembled Units	<p>The maximum deviation from square using the longest edge as the base.</p> <p>Stone assemblies consisting of two or more stones, plant assembled, using high strength adhesives and metal accessories where required.</p>
Smooth Finish	This is the generally recognized smoothest of the standard limestone finishes. It presents the least interruption of surface to eye or touch, and may be produced by a variety of machines.
Diamond Gang Sawed Finish	This finish is comparatively smooth but may contain some parallel markings and scratches. Direction of the markings and scratches will be vertical or horizontal in the wall unless the direction is specified.
Chat-Sawed Finish (Gang Sawed)	A medium rough somewhat uniform granular finish. It is produced by sawing with a coarse abrasive containing some metallic minerals which may add permanent brown tones to the natural color variations. This finish may contain parallel score or saw marks. Direction of the score or saw marks will be vertical or horizontal in the wall unless the direction is specified.
Shot Sawed Finish (Gang Sawed)	A coarse, uneven finish ranging from a pebbled surface to one ripped with irregular parallel grooves. Direction of the grooves will be vertical or horizontal in the wall unless the direction is specified. The random markings are obtained by using steel shot in the sawing process. The shot markings are uncontrolled and deviations in the sawn face may appear at the joint lines. Additional color tones may appear due to varying amounts of rust stains from the steel shot.
Custom Finishes	A wide variety of these finishes is available. Custom designed, textural finishes are a regular product of cooperation between architect and fabricator. Special tolerances, when required, should be established by agreement.

Note: For additional, more specific information on finishes see pages 48 and 49 of this handbook.

beams and lintels of indiana limestone

This table has been revised in an effort to make it a bit more user-friendly. The information and data used are identical to that contained in the previous (20th Edition) Handbook, but the unit-load method of presentation is different. We hope you find the new format to your liking.

Allowable Superimposed Uniform Load (W) in Pounds per Lineal Foot, per Inch of Lintel Width.

(L) SPAN FEET	(H) HEIGHT OF BEAM OR LINTEL—INCHES															(L) SPAN FEET
	2	4	6	8	10	12	14	16	18	20	22	24	26	28	30	
1	36.9	151.6	344.0	614.2	962.2	1,388.0	1,786.0	1,784.0	1,782.0	1,780.0	1,778.0	1,776.0	1,774.0	1,772.0	1,770.0	1
2	7.7	34.9	81.5	147.6	233.1	338.0	462.4	606.2	769.5	880.0	878.0	876.0	874.0	872.0	870.0	2
3	2.3	13.3	32.9	61.1	98.0	143.6	197.7	260.5	332.0	412.1	500.8	576.0	574.0	572.0	570.0	3
4	0.4	5.7	15.9	30.9	50.8	75.5	105.1	139.6	178.9	223.1	272.1	326.0	384.8	422.0	420.0	4
5	—	2.2	8.0	16.9	28.9	44.0	62.2	83.6	108.0	135.6	166.2	200.0	236.9	276.9	320.0	5
6	—	0.3	3.7	9.3	17.0	26.9	38.9	53.1	69.5	88.0	108.7	131.6	156.6	183.7	213.1	6
7	—	—	1.1	4.7	9.8	16.6	24.9	34.8	46.3	59.4	74.0	90.3	108.1	127.6	148.6	7
8	—	—	—	1.7	5.2	9.9	15.8	22.9	31.2	40.8	51.5	63.5	76.7	91.1	106.7	8
9	—	—	—	—	2.0	5.3	9.5	14.7	20.9	28.0	36.1	45.1	55.1	66.1	78.0	9
10	—	—	—	—	—	2.0	5.1	8.9	13.5	18.9	25.1	32.0	39.7	48.2	57.5	10
11	—	—	—	—	—	—	1.7	4.6	8.0	12.1	16.9	22.3	28.3	35.0	42.3	11
12	—	—	—	—	—	—	—	1.3	3.9	7.0	10.7	14.9	19.6	24.9	30.8	12
13	—	—	—	—	—	—	—	—	0.6	3.0	5.8	9.1	12.9	17.1	21.8	13
14	—	—	—	—	—	—	—	—	—	—	2.0	4.6	7.5	10.9	14.6	14
15	—	—	—	—	—	—	—	—	—	—	—	0.9	3.2	5.9	8.9	15
16	—	—	—	—	—	—	—	—	—	—	—	—	—	1.8	4.2	16
17	—	—	—	—	—	—	—	—	—	—	—	—	—	—	0.3	17
18	—	—	—	—	—	—	—	—	—	—	—	—	—	—	—	18
19	—	—	—	—	—	—	—	—	—	—	—	—	—	—	—	19
20	—	—	—	—	—	—	—	—	—	—	—	—	—	—	—	20

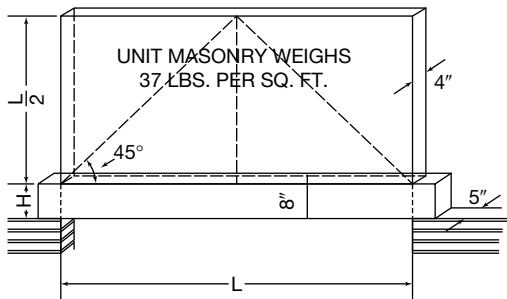

The Beam & Lintel Table is based on a rectangular loading pattern as shown. The actual loading by unit masonry when mortar sets approximates a triangle as shown by the dotted lines. Therefore, the table is conservative.

The weight of the lintel is calculated into this table and formula. The designer need make no further allowance for the weight of the stone.

General Equation

$$W = 9.7222 \times (H/L)^2 - H,$$

where H = height in inches and L = span in feet

Example

$$L = 6'-0''$$

$$H = 8''$$

$$\text{Lintel width} = 5''$$

$$W \text{ (from table)} = 9.3 \text{ pounds per lineal foot (per inch of width).}$$

$$\text{Allowable superimposed uniform load} = 9.3 \times 5'' \text{ width} = 46.5 \text{ pounds per lineal foot.}$$

$$\text{Total superimposed load} = 46.5 \times 6 \text{ feet long} = 279 \text{ pounds.}$$

The allowable loads shown are based on a modulus of rupture of 700 and a safety factor of 8 to 1. Much Indiana Limestone production exceeds this minimum. Capacities for such stone should be based on an appropriate engineering analysis, not on the values shown on the table.

The values shown above the dotted line are governed by shear stress based on 4" bearing on each end of the beam.

The values in the table are based on vertical gravity loads only and do not account for wind, seismic or other loads. The compression surface must be laterally supported when required to avoid lateral buckling.

arch theory and practice

Masonry arches, properly constructed, can carry their own weight plus heavy imposed loads for centuries, as demonstrated in thousands of ancient buildings. However, in contemporary construction, arch theory and good practice are too often ignored. This section is not intended to explain arch theory, but to set forth the basic principles of arch design for consideration.

When considering the feasibility of a true, load-bearing masonry arch, designers need to think first about thrust. An arch transfers load to its two end support points both as vertical load and as horizontal thrust load at each end. Mass or structural strength is required at the seats to resist this thrust without significant lateral movement. As the arch becomes flatter, not only does the likelihood of tension in the joints between elements of the arch increase, thrust increases as well. Thrust loads can be very high. Modern structures very often do not have sufficient mass or rigidity to adequately resist this thrust at the support points.

Bearing is also an issue. The designer must calculate not only the thrust and the ability of the sidewalls to resist it, but the capacity of the base structures to support the transmitted vertical load.

Finally, the designer must know the weight of the arch itself as well as the superimposed dead and live loads the arch must carry. It must be noted that for an arch to function properly, a certain amount of superimposed material and superimposed load is required.

If the arch cannot be designed to properly support the design bearing loads and thrust, gravity support for the components forming the arch must be provided.

For additional information, contact the Indiana Limestone Institute or its member companies.

using steel lintels with indiana limestone

When using ILIA's lintel table, designers may find their proposed application exceeds the safe load capacity of the limestone lintel and they may conclude that a steel lintel angle is needed. While that may be true, placing it UNDER the over-loaded stone lintel may not be appropriate. The reason is that a typical steel lintel will almost always be considerably less stiff than a stone lintel of the same span. (For example, a 4" x 10" limestone lintel is approximately 12 times stiffer than a 4" x 4" x 5/16" steel angle.) Therefore, because of the difference in stiff-

ness, a typical steel lintel will carry very little of the total load and the stone lintel will probably still be over-loaded.

The place for a steel angle intended to relieve a stone lintel of the same span is in the masonry field above. With a soft joint between it and the stone lintel below, the steel angle carries the weight of the masonry above, thereby reducing the load on the stone to a safe level.

Another option would be to joint the stone lintel into two, three or more pieces. Then design and install a steel lintel capable of carrying all of the masonry above including the now-jointed stone panels themselves. Each of these shorter stones should be evaluated for superimposed load, span and support conditions on the steel angle. Deflection as well as stress of the steel lintel should be considered.

cleaning new construction

Cut Indiana Limestone is customarily shipped as it comes from the final operation in the supplier's plant. Its surfaces and joints may be covered with dust or saw slush, especially those pieces which have not been exposed to rain in stacking areas. Cleaning prior to installation or erection of cut Indiana Limestone is not required where the existence of dust or slush does not impede the erection process or the application of joint sealants or pointing. The exception to this rule is interior stonework. Thoroughly clean interior stones prior to installation, and protect the work once in place from construction dust and traffic.

The method most used, and generally viewed as most successful, is pressure cleaning. Often, the required pressure can be delivered from ordinary hose-taps. If a greater scrubbing action is required, water pressure at no more than 1,200 psi, delivered by a wide-angle nozzle from a distance no closer than one foot to the stone surfaces, may be used. Most often, a lower pressure and greater distance will be equally effective and faster.

Other methods may be used. They may be dictated because of a large amount of architectural enrichment or ornamentation, or because the stone is used primarily as trim with other materials, or because the stone is affected by a greater-than-usual amount of jobsite dirt. Hand-scrubbing with fiber bristle brushes and mild soap or detergent solutions is acceptable.

In any case, ALL JOINT MATERIALS SHOULD BE IN PLACE, and care should be taken that neither pressure nor abrasion methods be used which may cause damage to sealants or pointing. Otherwise, the water used

in cleaning may be forced into the walls. Whatever procedures and materials may be chosen for final or intermediate cleandown, the result should be stone completely free of dust and grit.

When limestone is used as trim in brick walls, it must be protected from the acid solutions often used to remove mortar smears from bricks. Minimum protection is provided by wetting the stone prior to cleaning the brick. Ideally, a film of water or plastic will be present as a surface across which the acid soup can flow.

Sometimes mortar is smeared on stone surfaces. Smears can usually be removed by scrubbing with stone dust and fiber brushes wetted with white vinegar. To avoid smearing mortar, allow mortar tags to take their initial set, and then remove with a trowel rather than "bagging," or wiping with a wet cloth. Pointing mortar can be easily placed in vertical joints using a grout bag or mortar gun.

Acids or chemical methods are not usually required to clean new Indiana Limestone. Where stubborn dirt or other foreign material is imbedded in the surfaces, ordinary abrasive cleaners will usually remove them. Should more radical methods be required, several commercial cleaners made specifically for limestone are available. ILI will be happy to consult on these matters.

Questions relating to restorative cleaning, and to the removal of small area stains are more fully addressed in a booklet entitled *How To Avoid Small Area Stains and Blemishes*. Copies may be obtained from any ILI member or from the ILI office on request.

indiana limestone in restoration

Indiana Limestone has enjoyed a storied place in architecture since the industry began in 1827 with the opening of the first quarry. It has been and continues to be used in governmental, educational, commercial and residential projects, among others, which are built to last 100 years and more. Many of these buildings have been designated as historic, while others make up complexes of buildings, particularly at colleges and universities throughout the country.

The Indiana Limestone industry prides itself in its ability to match stone quarried many years ago with their current production. This is an excellent asset, particularly when considering additions to existing buildings, when new buildings are added to an existing complex or

when stone replacements are done in restoration efforts. However, it should be noted that this matching process may not occur immediately. New stone will often contain moisture and organic materials which may initially cause it to look darker than the original stone. Conversely, there are times when the new stone may look cleaner than the existing stone, particularly if it has been quarried long enough to have seasoned (see page 7 for more on seasoned stone). This is especially true if the existing stone has not been cleaned for some period of time and/or is in a highly industrialized environment. Often the new stone looks new, and the old stone looks old, but eventually, usually sooner rather than later, the new and old stone will blend into a pleasing match through weather cycles. ILI advises against the use of any artificial means of coloring to accomplish this, preferring instead to allow this blending to occur naturally over time.

Indiana Limestone is virtually maintenance-free, requiring only the re-pointing or re-caulking of joints and possible periodic cleaning. With the emphasis today on the preservation of older buildings, more and more architects, contractors and ILI members are engaged in this type of work. With that in mind, we would like to offer the following brief introduction to the cleaning, re-pointing and repair of Indiana Limestone buildings.

general comments on major cleaning procedures

Probably more damage to fine older buildings is done by inept building cleaners than by years of exposure to corrosive atmospheres. Unfortunately, many decisions to clean buildings are made without adequate preparatory steps and without investigation of alternate methods, their costs and results.

Consideration should be given first to the easiest and cleanest method which will produce desired results. In some cases, for instance, a low-pressure hosing will remove enough accumulated dirt to expose the basic color of the building materials and to reveal long-hidden architectural detail.

Not all buildings will clean up so easily, and different areas of the same building may require different treatments. A general rule should be to use the most conservative treatment or material which will achieve the required degree of cleanliness. The contractor should have adequate insurance to protect both himself and his client against damage to neighboring structures, to materials on buildings which are not in his contract, adjacent foliage and landscaping, and passersby.

Cleaning methods are categorized as wet, dry and chemical. Each has its place and sometimes all must be used to achieve desired results. Architects and clients should decide how clean the building should be and what degree of mess they are willing to allow to achieve it. Preliminary talks with building cleaning personnel and demonstrations on test patches on the building will aid immeasurably in the decisions.

Wet cleaning methods include scrubbing, either manually or by machine; high- and low-pressure hosing with water at various temperatures; slow soaking with pierced hose; and steam. A combination of grit blast and aerated water called "wet-aggregate" often is used.

Dry cleaning methods include ordinary sandblast, and grinding or sanding both by hand and with various handheld sanders. Sandblasting should be used only as a last resort.

The chemical agents used to clean buildings are usually acidic. Improper dilutions of these materials can cause damage to limestone. Manufacturers' instructions should be carefully noted and used when chemicals are used to clean limestone. Generic acid cleaners such as muriatic acid should not be used in strengths which cause discoloration of the stone.

In general, when wet or chemical cleaning methods are used, ILI recommends that jointwork be done prior to cleaning. Many building cleaning contractors prefer to tuckpoint or seal joints after cleaning; however, unsound joints may admit water, especially under pressure, and stain and/or damage to interior finishes may result.

Dry cleaning methods should be used sparingly. Many cities have prohibitions against sandblast; it should be done only on covered scaffold by personnel skilled in building cleaning with that method. Grinding produces a fine dust which must be controlled and uneven grinding pressure may pattern the stone in uneven swirls or streaks. Grinding may be used on flat surfaces; ornament or enrichment may be cleaned with handheld sandpaper.

The cleaning of older buildings should not be confused with cleaning new construction which should require no more aggressive methods than low-to medium-pressure cleaning, with occasional scrubbing. Additional information on cleaning new construction can be found on pages 38 & 39.

Comments on the use of water repellent treatments apply as well to newly cleaned buildings as to new construction. A reprint of ILI's Water Repellent Technote can be found on pages 31 and 32.

re-pointing indiana limestone

When re-pointing joints, proper joint preparation is particularly important. One traditional mortar pointing spec is reprinted here for the information of the reader:

1. Old mortar should be removed to a minimum depth of 2 to 2½ times the width of the joint or until sound mortar is reached to ensure an adequate bond and to prevent mortar "pop-outs."
2. Do not remove mortar in excess of 1/3 the depth of the masonry unit.
3. The mortar should be cut back to a uniform depth.
4. Dust and debris should be removed from the joint by brushing, rinsing with water or blowing with air.

ILI recommends nothing stronger than a Type N mortar be used in pointing or re-pointing Indiana Limestone joints. This is explained in some detail on pages 22 and 23 of this Handbook.

One sample guide on mixing procedures for re-pointing mortar is as follows:

1. Use pre-hydrated mortar to reduce shrinkage.
2. Measure and place all ingredients in a tub or mixing box.
3. Thoroughly mix all dry ingredients.
4. Add 1/2 the amount of water used in new construction.
5. Mix the mortar until it holds its shape when formed into a solid ball. There should be no flow or spread of mortar.
6. Let the mix hydrate for one to two hours.
7. Add more water to make the mix workable, but still relatively stiff, which results in good workability and minimum smearing.
8. Repeat all of the above steps for additional mixes.

One sample guide on pointing mortar application procedures is as follows:

1. Joints to be pointed should be dampened to make sure the new mortar makes a good bond; the masonry units must absorb all the surface water.
2. A wide variety of tools are available to pack mortar into the prepared joints. Choose a tool with a width slightly smaller than the width of the joints.
3. Apply the mortar into the joints in 1/4" thick layers or less to reduce the potential for air pockets and voids. This procedure helps to control shrinkage.

4. Continue filling the joint down the wall. As soon as the mortar has dried to thumbprint hard, apply another 1/4" layer of mortar on top.
5. Several layers of mortar will be needed to fill the joint flush to the surface.
6. When the final layer of mortar is thumbprint hard, the joint should be tooled to match the historic joint.
7. It is important to allow time for each layer to harden before the next layer is applied; most of the mortar shrinkage occurs during the hardening process and layering thus minimizes overall shrinkage.

Proper attention to detail during re-pointing will result in solid, dependable mortar joints increasing the life-span of the building for many years to come.

ILI takes no official position on the use of mortar vs. the use of joint sealants, as both are recognized as accepted joint materials for Indiana Limestone. However, our tendency is to recommend that where mortar was used in the original building, the joints should be re-pointed with mortar and, conversely, when sealant was the original material, sealant should be used in the restoration effort. For more information on the use of sealants, see pages 25, 145 & 146 of this Handbook.

stone replacement

Sometimes in repair and restoration efforts the decision is made to remove and replace deteriorated stone rather than to attempt to repair it. Among the considerations might be the extent of damage to the original stone, which could make it difficult to repair, and the ease or difficulty of being able to safely remove it. In these instances architects, contractors and owners should be aware of the possibility of damaging some of the surrounding stones, thus the original method of construction should be determined and understood prior to beginning the replacement process. Another important factor is to determine the grade, color and finish of the stone being replaced so that an accurate selection of replacement stones can be made. If the building is dirty, a good ploy is to take a bucket of laundry detergent and water and a fiber-bristle brush and clean some sample stones in (preferably) hard-to-see locations, then compare the clean stone with samples submitted for the replacements. Area ILI members can often be helpful in these efforts, as they can generally identify the stone and original finish in question. It is especially critical to know this prior to the bidding process so that an accurate specification can be issued and prospective bidders will know what material they are to supply. As noted in the second paragraph of this section, one of the positives of Indiana Limestone is the industry's ability to match

material quarried many years ago with what is being quarried today, though it may not match at the time the replacements are done. Over time, however, as previously noted, weather cycles and atmospheric and environmental conditions will work to blend the stone into a pleasing match to the rest of the project.

repairing damage to indiana limestone

Various methods are used in the repair of Indiana Limestone, both on older buildings and in new work. The method used often depends on the type and extent of damage to the stone. The success of any repair project depends in large measure on selecting the right material and on choosing a contractor with the experience both in the use of the product and in doing the necessary repairs. Among the most popular repair products are cement-based and epoxy-based patch materials.

cementitious repair materials

Cementitious patches have evolved over the years and are available from a variety of producers for many different types of stone. Some are meant for relatively small chips and snips and are typically use in the repair of new work, while others were developed for larger areas and are extensively used in restoration.

Cementitious materials used in new work are often available from stone suppliers and are generally used at the job-site for the repair of small chips and snips. They are also used in the mill from time to time as well. Job-site repairs, in particular, can be a source of trouble in new work if they aren't performed in a workmanlike manner. Patches which are poorly color-matched or poorly textured are readily noticeable and often cause angst among owners. Manufacturers of these products are generally able to advise users of their materials on the proper procedures to follow when using their material. ILI allows the repair of new work and suggests that small chips and snips that neither detract from the overall project nor impair the effectiveness of the mortar or sealant be left alone. More information on the repair of new work can be found in the ILI Technote on Damage and Repair Practices and Standards, available upon request.

Cementitious materials used in restoration work have evolved over the years and were developed for larger areas of damage. While some job-site mixing is still required, much of the guesswork has been eliminated by their manufacturers. Laboratories at these compa-

nies often take samples of the stone to be repaired and color-match their patch material to them. The patch is then shipped in powder form to the project and requires only the addition of water. Surface preparation is important in any repair exercise, but is especially critical when using the cementitious materials. Suppliers of these materials are generally happy to instruct users on proper repair procedures and many of them offer classes on the subject as well.

epoxy repair materials

While epoxy materials have been widely used in restoration work to re-attach broken stones, the industry has also developed materials used in patching. When bonding, repairing or patching limestone, there are a few important considerations for deciding which adhesive system to use. When bonding, laminating or re-attaching two pieces of stone together, (approximately 1/16" to 1/32" in joint thickness), manufacturers typically recommend the use of an exterior grade, structural epoxy. They also generally recommended the use of a pre-colored epoxy similar in color to that of the limestone, thus limiting any straining or bleeding into the face of the stone.

For patching and "Dutchman" replacement of limestone, the following systems are recommended. When patching small chips, pits or spalls, it is a good idea to use an adhesive recommended by the manufacturer for limestone applications. The patching adhesive should be exterior-grade, UV-stable and exhibit no shrinkage, thus limiting "pop-offs" or delamination. When replacing an existing piece of stone with a new piece of stone ("Dutchman") it is recommended to re-attach the stone with a structural, pre-colored epoxy. Note that some epoxy adhesives may not be suitable for the limestone industry or for some specific applications. As with most products used with Indiana Limestone, it's a good idea to contact the specific manufacturers for their recommendations and a data sheet to verify the applicability of their product for your project prior to specifying or using the product.

The above information represents, to the best of our belief, the state of the industry at the time of this writing. As previously stated, this is meant to be a general information guide and is not meant to be used in place of manufacturer's directions. More information on restoration and cleaning procedures is available upon request through ILI and our member companies.

seismic considerations

Local codes should always be consulted for seismic (earthquake) loading requirements and such requirements should be considered in anchorage design. In some areas, design seismic loads may exceed design wind loads. Also, while design wind loads act either inward or outward perpendicular to the face of the panels being evaluated, design seismic loads can act in any horizontal direction including laterally, parallel to the face of the cladding. In some cases, these design lateral seismic loads may be less than design wind loads but will be significant enough to affect anchor designs.

Beyond the specific requirements set forth in various codes, there is a wide variety of literature available on the subject. The following list of publications is representative, but not exhaustive.

Name	Publisher
<i>Seismic Design for Buildings</i>	Office of Engineers, U.S. Army identified as TM 5-809-10
<i>Earthquake Resistant Masonry Construction</i>	National Bureau of Standards identified as NBS Science series 106
<i>Abnormal Loading on Buildings and Progressive Collapse: An Annotated Bibliography</i>	National Bureau of Standards identified as NBS Science series 67

storage and handling

Like many other construction materials, Indiana Limestone is heavy. All workers unloading and/or handling this material should be trained in appropriate and safe handling procedures and methods.

All Indiana Limestone should be carefully unloaded at the storage or building site by competent workmen. The stone should be handled by such methods as will guard against soiling, mutilating or chipping. Pliable sling belts of 3" or more in width should be used, and the belts should be of sufficient length so that the edges of stone will not be under pressure great enough to cause chipping. All stone should be stacked on pallets or skids, clear of ground to provide protection from dirt stains. The stone should be covered with a clean tarpaulin, strong, nonstaining waterproof paper, or polyethylene plastic, during extended periods of storage or when necessary to protect from damage.

When stone is stacked, the faces should be separated by nonstaining skids. Only two skids per stone should be used and they should be placed one-fourth of the length of the stone from each end. To prevent breakage, make sure the skids are placed directly above each other. Use wood skids made from cypress, white pine, poplar, or yellow pine that does not contain excessive amounts of resin. Do not use chestnut, walnut, oak, or other woods containing tannin.

Do not stack stones to excessive height, so that the weight of the stone compresses the spacers and increases the possibility of damage to edges.

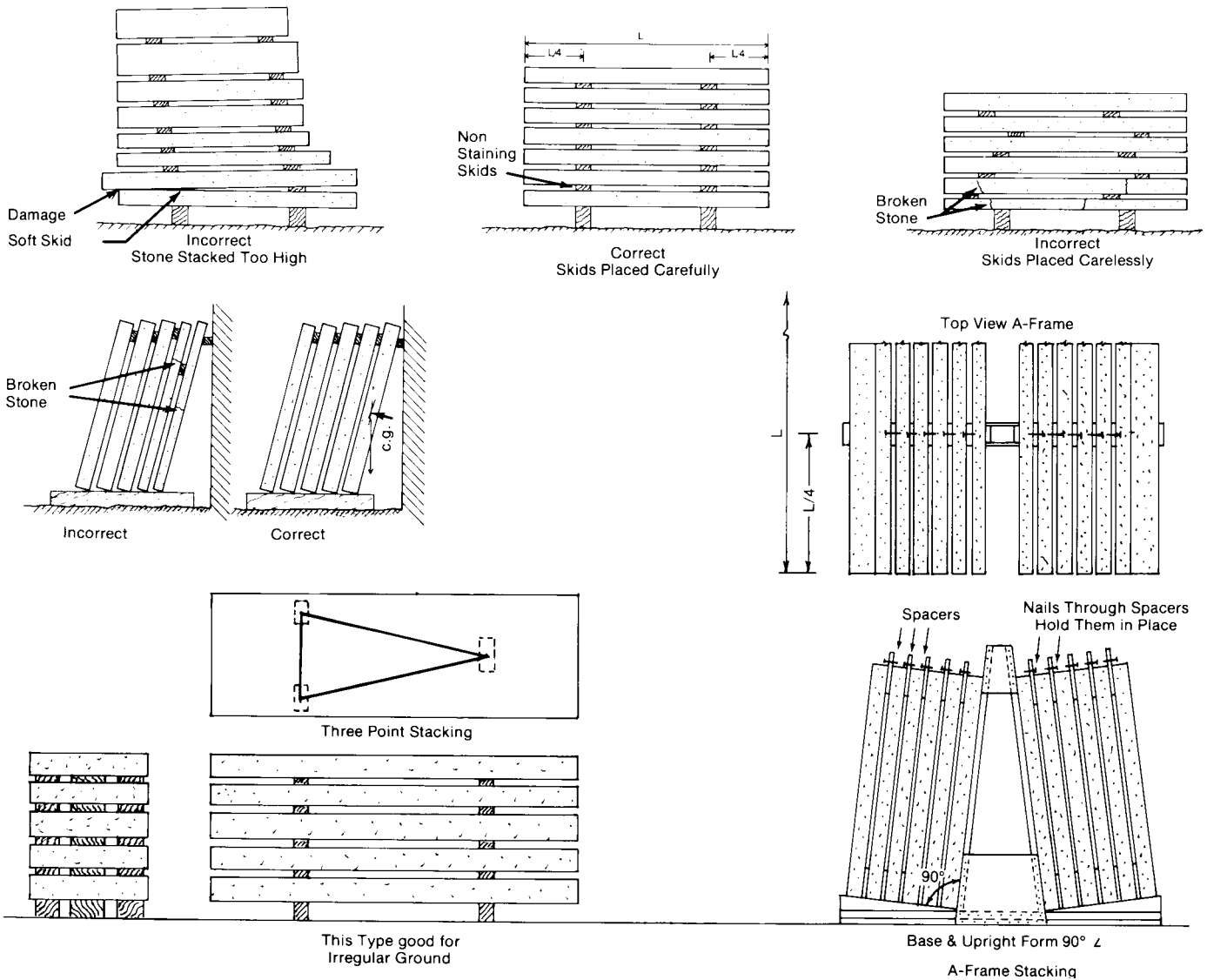

The supplier of cut Indiana Limestone will provide holes and sinkages for both anchoring and lifting. However, it is the responsibility of the general contractor or erector to correlate the types of equipment he plans to use with the matching types of lifting holes to be provided by the supplier. Where no arrangements are made, the supplier will provide those sinkages, if any, which suit his own handling requirements. Do not use Lewis devices in stones under 3 1/2" thick.

Note: ILI has included this page for illustrative purposes only. This information is not intended as a guide to lifting procedures. Commercial chain, clamps, pins and other devices are available. Their manufacturers will provide instructions for their safe and proper use.

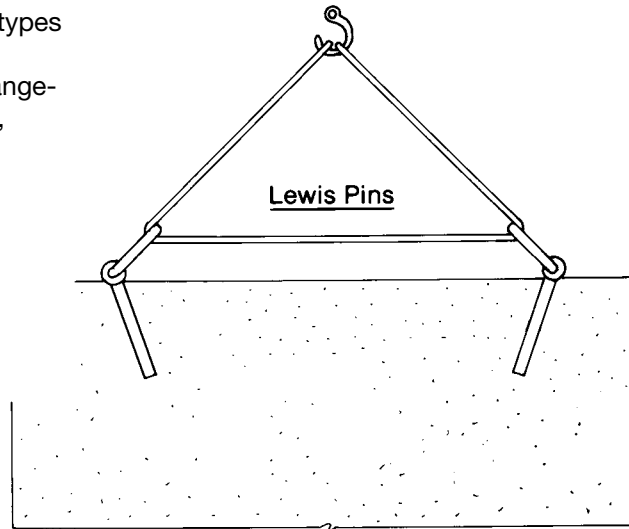

Slings

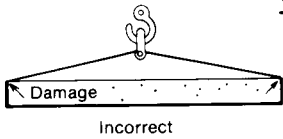

Too-short slings cause damage at stone edges. Loads lifted by such slings tend to be unstable.

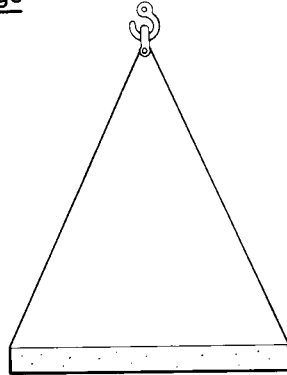

Box Lewis

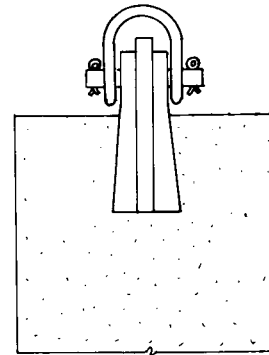

Stone Clamp

Lifting Pulley allows self-leveling of stone.

Sometimes two clamps can handle heavy stones better.

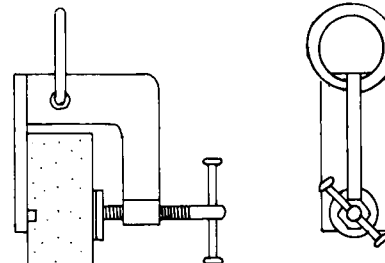
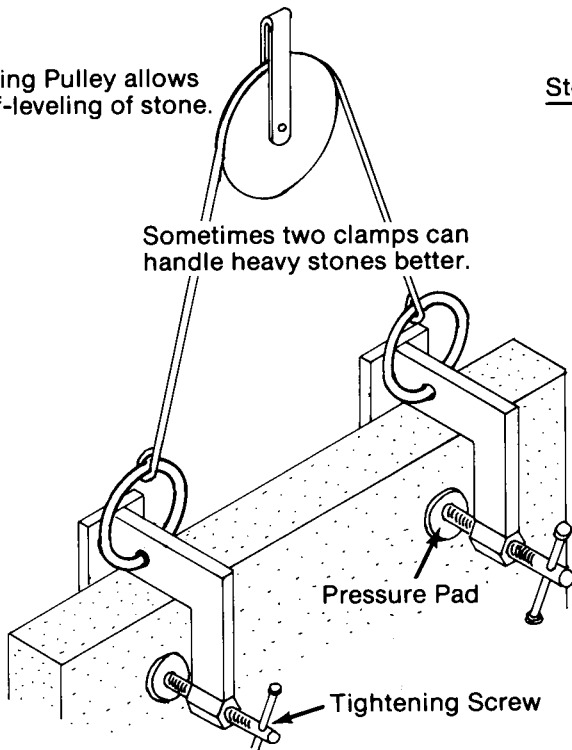

On textured finishes, a ribbed pressure pad evenly distributes the clamp pressure to the smooth surface.

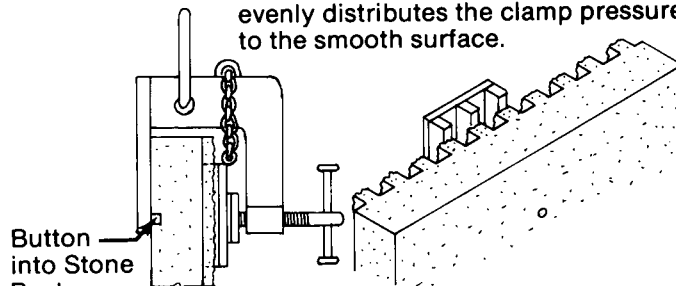

Chain retains ribbed pressure pad from falling when loosened.

Note: Pins, box Lewises and other devices attached to or near the tops of stones should not be used to raise stone panels to vertical position from the horizontal. They may, however, be used in conjunction with slings or other devices which support the main weight of panels while turning them to the position for installation. **In contemporary stone design and usage, Lewis devices are unreliable and dangerous.** ILI recommends against their use by persons unfamiliar with safe practices.

metrication tables

Conversion to Metric Units

Conversion from Metric Units

LINEAR MEASURE (LENGTH)

To convert	Multiply by	To convert	Multiply by
inches to millimeters	25.4	millimeters to inches	0.039
inches to centimeters.....	2.54	centimeters to inches.....	0.394
feet to meters.....	0.305	meters to feet.....	3.281
yards to meters	0.914	meters to yards	1.094
miles to kilometers	1.609	kilometers to miles	0.621

SQUARE MEASURE (AREA)

To convert	Multiply by	To convert	Multiply by
sq. inches to sq. centimeters.....	6.452	sq. centimeters to sq. inches.....	0.155
sq. feet to sq. meters.....	0.093	sq. meters to sq. feet.....	10.764
sq. yards to sq. meters	0.836	sq. meters to sq. yards	1.196
acres to hectares	0.405	hectares to acres	2.471

CUBIC MEASURE (VOLUME)

To convert	Multiply by	To convert	Multiply by
cu. inches to cu. centimeters.....	16.387	cu. centimeters to cu. inches.....	0.061
cu. feet to cu. meters.....	0.028	cu. meters to cu. feet.....	35.315
cu. yards to cu. meters	0.765	cu. meters to cu. yards	1.308

LIQUID MEASURE (CAPACITY)

To convert	Multiply by	To convert	Multiply by
fluid ounces to liters.....	0.03	liters to fluid ounces.....	33.814
quarts to liters	0.946	liters to quarts	1.057
gallons to liters.....	3.785	liters to gallons.....	0.264
imperial gallons to liters	4.546	liters to imperial gallons	0.220

WEIGHTS (MASS)

To convert	Multiply by	To convert	Multiply by
ounces avoirdupois to grams.....	28.35	grams to ounces avoirdupois.....	0.035
pounds avoirdupois to kilograms.....	0.454	kilograms to pounds avoirdupois.....	2.205
tons to metric tons.....	0.907	metric tons to tons.....	1.102

TEMPERATURE

Fahrenheit thermometer	Celsius (or Centigrade) thermometer
32 degrees F	freezing point of water 0 degrees C
212 degrees F	boiling point of water 100 degrees C
98.6 degrees F	body temperature 37 degrees C

To find degrees Celsius, subtract 32 from degrees Fahrenheit and divide by 1.8.
 To find degrees Fahrenheit multiply degrees Celsius by 1.8 and add 32.

nominal height of masonry walls by courses for brick and block

COURSES	REGULAR 4 2 ¹ / ₄ " bricks + 4 equal joints =					MODULAR 3 bricks + 3 joints =	CONCRETE BLOCKS	
	10" ¹ / ₄ " joints	10 ¹ / ₂ " ³ / ₈ " joints	11" ¹ / ₂ " joints	11 ¹ / ₂ " ⁵ / ₈ " joints	12" ³ / ₄ " joints	8"	3 ⁵ / ₈ " blocks ³ / ₈ " joints	7 ⁵ / ₈ " blocks ³ / ₈ " joints
1	2 ¹ / ₂ "	2 ⁵ / ₈ "	2 ³ / ₄ "	2 ⁷ / ₈ "	3"	2 ¹¹ / ₁₆ "	4"	8"
2	5"	5 ¹ / ₄ "	5 ¹ / ₂ "	5 ³ / ₄ "	6"	5 ⁵ / ₁₆ "	8"	1'4"
3	7 ¹ / ₂ "	7 ⁷ / ₈ "	8 ¹ / ₄ "	8 ⁵ / ₈ "	9"	8"	1'0"	2'0"
4	10"	10 ¹ / ₂ "	11"	11 ¹ / ₂ "	1'0"	10 ¹¹ / ₁₆ "	1'4"	2'8"
5	1'0 ¹ / ₂ "	1'1 ¹ / ₈ "	1'1 ³ / ₄ "	1'2 ³ / ₈ "	1'3"	1'1 ⁵ / ₁₆ "	1'8"	3'4"
6	1'3"	1'3 ³ / ₄ "	1'4 ¹ / ₂ "	1'5 ¹ / ₄ "	1'6"	1'4"	2'0"	4'0"
7	1'5 ¹ / ₂ "	1'6 ³ / ₈ "	1'7 ¹ / ₄ "	1'8 ¹ / ₈ "	1'9"	1'6 ¹¹ / ₁₆ "	2'4"	4'8"
8	1'8"	1'9"	1'10"	1'11"	2'0"	1'9 ⁵ / ₁₆ "	2'8"	5'4"
9	1'10 ¹ / ₂ "	1'11 ⁵ / ₈ "	2'0 ³ / ₄ "	2'1 ⁷ / ₈ "	2'3"	2'0"	3'0"	6'0"
10	2'1"	2'2 ¹ / ₄ "	2'3 ¹ / ₂ "	2'4 ³ / ₄ "	2'6"	2'2 ¹ / ₁₆ "	3'4"	6'8"
11	2'3 ¹ / ₂ "	2'4 ⁷ / ₈ "	2'6 ¹ / ₄ "	2'7 ⁵ / ₈ "	2'9"	2'5 ⁵ / ₁₆ "	3'8"	7'4"
12	2'6"	2'7 ¹ / ₂ "	2'9"	2'10 ¹ / ₂ "	3'0"	2'8"	4'0"	8'0"
13	2'8 ¹ / ₂ "	2'10 ¹ / ₈ "	2'11 ³ / ₄ "	3'1 ³ / ₈ "	3'3"	2'10 ¹¹ / ₁₆ "	4'4"	8'8"
14	2'11"	3'0 ³ / ₄ "	3'2 ¹ / ₂ "	3'4 ¹ / ₄ "	3'6"	3'1 ⁵ / ₁₆ "	4'8"	9'4"
15	3'1 ¹ / ₂ "	3'3 ³ / ₈ "	3'5 ¹ / ₄ "	3'7 ¹ / ₈ "	3'9"	3'4"	5'0"	10'0"
16	3'4"	3'6"	3'8"	3'10"	4'0"	3'6 ¹¹ / ₁₆ "	5'4"	10'8"
17	3'6 ¹ / ₂ "	3'8 ⁵ / ₈ "	3'10 ³ / ₄ "	4'0 ⁷ / ₈ "	4'3"	3'9 ⁵ / ₁₆ "	5'8"	11'4"
18	3'9"	3'11 ¹ / ₄ "	4'1 ¹ / ₂ "	4'3 ³ / ₄ "	4'6"	4'0"	6'0"	12'0"
19	3'11 ¹ / ₂ "	4'1 ⁷ / ₈ "	4'4 ¹ / ₄ "	4'6 ⁵ / ₈ "	4'9"	4'2 ¹¹ / ₁₆ "	6'4"	12'8"
20	4'2"	4'4 ¹ / ₂ "	4'7"	4'9 ¹ / ₂ "	5'0"	4'5 ⁵ / ₁₆ "	6'8"	13'4"
21	4'4 ¹ / ₂ "	4'7 ¹ / ₈ "	4'9 ³ / ₄ "	5'0 ³ / ₈ "	5'3"	4'8"	7'0"	14'0"
22	4'7"	4'9 ³ / ₄ "	5'0 ¹ / ₂ "	5'3 ¹ / ₄ "	5'6"	4'10 ¹¹ / ₁₆ "	7'4"	14'8"
23	4'9 ¹ / ₂ "	5'0 ³ / ₈ "	5'3 ¹ / ₄ "	5'6 ¹ / ₈ "	5'9"	5'1 ⁵ / ₁₆ "	7'8"	15'4"
24	5'0"	5'3"	5'6"	5'9"	6'0"	5'4"	8'0"	16'0"
25	5'2 ¹ / ₂ "	5'5 ⁵ / ₈ "	5'8 ³ / ₄ "	5'11 ⁷ / ₈ "	6'3"	5'6 ¹¹ / ₁₆ "	8'4"	16'8"
26	5'5"	5'8 ¹ / ₄ "	5'11 ¹ / ₂ "	6'2 ³ / ₄ "	6'6"	5'9 ⁵ / ₁₆ "	8'8"	17'4"
27	5'7 ¹ / ₂ "	5'10 ⁷ / ₈ "	6'2 ¹ / ₄ "	6'5 ⁵ / ₈ "	6'9"	6'0"	9'0"	18'0"
28	5'10"	6'1 ¹ / ₂ "	6'5"	6'8 ¹ / ₂ "	7'0"	6'2 ¹¹ / ₁₆ "	9'4"	18'8"
29	6'0 ¹ / ₂ "	6'4 ¹ / ₈ "	6'7 ³ / ₄ "	6'11 ³ / ₈ "	7'3"	6'5 ⁵ / ₁₆ "	9'8"	19'4"
30	6'3"	6'6 ³ / ₄ "	6'10 ¹ / ₂ "	7'2 ¹ / ₄ "	7'6"	6'8"	10'0"	20'0"
31	6'5 ¹ / ₂ "	6'9 ³ / ₈ "	7'1 ¹ / ₄ "	7'5 ¹ / ₈ "	7'9"	6'10 ¹¹ / ₁₆ "	10'4"	20'8"
32	6'8"	7'0"	7'4"	7'8"	8'0"	7'1 ⁵ / ₁₆ "	10'8"	21'4"
33	6'10 ¹ / ₂ "	7'2 ⁵ / ₈ "	7'6 ³ / ₄ "	7'10 ⁷ / ₈ "	8'3"	7'4"	11'0"	22'0"
34	7'1"	7'5 ¹ / ₄ "	7'9 ¹ / ₂ "	8'1 ³ / ₄ "	8'6"	7'6 ¹¹ / ₁₆ "	11'4"	22'8"
35	7'3 ¹ / ₂ "	7'7 ⁷ / ₈ "	8'0 ¹ / ₄ "	8'4 ⁵ / ₈ "	8'9"	7'9 ⁵ / ₁₆ "	11'8"	23'4"
36	7'6"	7'10 ¹ / ₂ "	8'3"	8'7 ¹ / ₂ "	9'0"	8'0"	12'0"	24'0"
37	7'8 ¹ / ₂ "	8'1 ¹ / ₈ "	8'5 ³ / ₄ "	8'10 ³ / ₈ "	9'3"	8'2 ¹¹ / ₁₆ "	12'4"	24'8"
38	7'11"	8'3 ³ / ₄ "	8'8 ¹ / ₂ "	9'1 ¹ / ₄ "	9'6"	8'5 ⁵ / ₁₆ "	12'8"	25'4"
39	8'1 ¹ / ₂ "	8'6 ³ / ₈ "	8'11 ¹ / ₄ "	9'4 ¹ / ₈ "	9'9"	8'8"	13'0"	26'0"
40	8'4"	8'9"	9'2"	9'7"	10'0"	8'10 ¹¹ / ₁₆ "	13'4"	26'8"
41	8'6 ¹ / ₂ "	8'11 ⁵ / ₈ "	9'4 ³ / ₄ "	9'9 ⁷ / ₈ "	10'3"	9'1 ⁵ / ₁₆ "	13'8"	27'4"
42	8'9"	9'2 ¹ / ₄ "	9'7 ¹ / ₂ "	10'0 ³ / ₄ "	10'6"	9'4"	14'0"	28'0"
43	8'11 ¹ / ₂ "	9'4 ⁷ / ₈ "	9'10 ¹ / ₄ "	10'3 ⁵ / ₈ "	10'9"	9'6 ¹¹ / ₁₆ "	14'4"	28'8"
44	9'2"	9'7 ¹ / ₂ "	10'1"	10'6 ¹ / ₂ "	11'0"	9'9 ⁵ / ₁₆ "	14'8"	29'4"
45	9'4 ¹ / ₂ "	9'10 ¹ / ₈ "	10'3 ³ / ₄ "	10'9 ³ / ₈ "	11'3"	10'0"	15'0"	30'0"
46	9'7"	10'0 ³ / ₄ "	10'6 ¹ / ₂ "	11'0 ¹ / ₄ "	11'6"	10'2 ¹¹ / ₁₆ "	15'4"	30'8"
47	9'9 ¹ / ₂ "	10'3 ³ / ₈ "	10'9 ¹ / ₄ "	11'3 ¹ / ₈ "	11'9"	10'5 ⁵ / ₁₆ "	15'8"	31'4"
48	10'0"	10'6"	11'0"	11'6"	12'0"	10'8"	16'0"	32'0"
49	10'2 ¹ / ₂ "	10'8 ⁵ / ₈ "	11'2 ³ / ₄ "	11'8 ⁷ / ₈ "	12'3"	10'10 ¹¹ / ₁₆ "	16'4"	32'8"
50	10'5"	10'11 ¹ / ₄ "	11'5 ¹ / ₂ "	11'11 ³ / ₄ "	12'6"	11'1 ⁵ / ₁₆ "	16'8"	33'4"

SECTION III

product use

Cost Factors to Consider	48
Finishes — Description and Adaptability	48-49
Production Diagram	49
How to Use the Indiana Limestone Grading System	50
Rock Face	50-52
PANELS	
Single Story	53
Floor Height	54
Grid Systems	55
Post Tensioned Assemblies	56
Anchorage to Existing Buildings	57
Two Connection Systems — Multi-Story, Steel Frame	58
Multi-Story, Masonry Backup	59
Multi-Story, Concrete Frame	60
Liner Blocks Supports	61
TYPICAL DETAILS	
Anchoring to CMU Backup	62
Steps and Platforms	63
Window Elements	64
Windows and Doors	65
Traditional Doors and Cornices	66-67
Soffits and Canopies	68
Limestone Coping	69
Preassemblies	70-72
Classic Details	73-79
Ashlar Veneer and Trim	80-82
Quoins, Watertables and Base Courses	83

cost factors to consider

The value of any building must be considered in broader terms than simply the initial cost to the owner.

Rentability, maintenance, cost of heating and air conditioning, beauty, permanence . . . all of these factors bear on the **ultimate** cost of a building.

The lowest **initial** cost is also important. Here are a few general suggestions to help lower the initial cost of limestone buildings.

SEEK competent help early in the design stages. The Indiana Limestone Institute, or any of its members, will assist with design, anchorage systems, joints, etc., to reduce fabrication and erection costs.

CHOOSE a grade of stone compatible with the finish desired. For the rougher finishes, a coarse, **less expensive** grade of stone can be used to accentuate the rough finish. For a smooth finish, a finer grade is usually desirable. If uniformity of color is not required, variegated stone can be the most economical selection.

SHOW all applicable sections, plans, details and joints. Including these pertinent details will enable the estimators to be more accurate in pricing your job, and will result in a lower cost.

REPEAT identical stones as often as the design will allow. This permits fabrication on a production basis—the greater the number of identical pieces, the lower the unit cost.

finishes—description and adaptability

Specifiers should always request and receive samples of Indiana Limestone for approval of texture, color, and particularly finish. While most finishes are generally understood and agreed on by limestone producers, innovation in machine types which reduce costs and simplify production may result in variations in surface appearance. The durability and ultimate value of the stone is not changed in any case.

1. SMOOTH FINISH

This is the least textural of standard limestone finishes and presents a minimum of surface interruption to the eye or to touch. The degree of smoothness is determined by the finishing method applied. Smooth finishes are produced in a variety of ways by a number of different machines and are sometimes called out as planer,

honed, grinder, machine, carborundum, bugged, or circular sander. All of these are classified as smooth finish. Specifying these individual applied methods will be considered as smooth, and one or more of the applicable methods may be used by the fabricator.

The smooth finish should not be confused with polished. Indiana Limestone with a polished finish may not yield the generally accepted degree of reflectivity and uniformity which appears on more crystalline stones so finished. ILI does not recommend specifying a polished finish on Indiana Limestone.

Some of the techniques for applying smooth finish are applicable only to flat surfaces. Where complex, curved, or molded surfaces occur in a building design, the producer may choose to use a variety of machines to produce them. Where finished stone will tend to be viewed at close range, such as in interior work or at building entrance features, matching finish types can be achieved by the use of matching production methods.

2. COARSE AND TEXTURED FINISHES

A. PLUCKED: a machine finish obtained by rough planing the surface of the stone, thus breaking or plucking out small particles. This gives an interesting rough texture. Plucked is occasionally used as a finish on the stone trim of buildings faced with a smooth finish.

B. MACHINE TOOLED: This finish consists of cutting parallel, concave grooves in the stone. It is available in four, six or eight bats (grooves) to the inch. The depth of the groove varies with the number of bats used but will range from 1/32" to 1/16" deep. Machine tooling is used primarily on ashlar surfaces. Tooled trim work can be economically machine cut only along the long dimension of the stone.

C. BUSHHAMMER: This finish is pneumatically applied, either by hand or by machine, and can range in texture from light to fairly coarse, though maximum relief will never exceed a fraction of an inch. Some variation in finish can occur by interchange of tools in the application head. This finish is best applied on flat surfaces, but can be applied by hand on radial surfaces. Coarser finishes require thicker stones. ILI recommends that the designer consult either with ILI or a member fabricator prior to specifying a bushhammer finish.

D. SPLIT FACE: A rough, uneven, concave-convex finish produced by the splitting action of a guillotine knife. The stones are split to the specified wall thickness (usually 3" to 4" thick), in random lengths, 1'-0" to 4'-0" long, and sawed to the specified course heights (see Ashlar Stone Veneer p. 80). This finish is limited to stone sizes 4'-0" by 1'-4" high.

Split face is available in ashlar stone veneer only. The rough, natural appearance creates maximum light and

shadow contrast. It is used extensively for residential, commercial, and ecclesiastical buildings, interior and exterior to emphasize horizontal lines and create a massive appearance.

When using this finish, specify color of stone only (buff, gray, or variegated). The stones will represent a complete range of grades, fine through coarse.

E. ROCK FACE: Rock face is a finish that has been dressed by machine or by hand to produce a bold, convex projection along the face of the stone. This finish provides a bolder, more massive appearance than split face. See pp. 50-52 for a detailed description of rock face finish.

F. CHAT SAWED: This finish results from the use of a coarse abrasive during the gang sawing operation.

It has a coarse pebbled surface which closely resembles the appearance of sand blasting. It will sometimes contain shallow saw marks or parallel scores. Direction of the score or saw marks will be vertical and/or horizontal in the wall unless the direction is specified. This finish may have a slight variation in color due to the presence of iron oxide in the saw slurry resulting from the wearing of the steel saw blades. This finish can be applied only to flat surfaces and is particularly suited to the various types of ashlar. For best economy, its use should be confined to the coarser grades of stone.

G. SHOT SAWED: This is a coarse, uneven finish ranging from a pebbled surface to one ripped with irregular,

roughly parallel grooves. The random markings are obtained by using steel shot in the gang sawing process in combination with chat sand. The steel shot rusts during this process, permitting varying amounts of rust stain to develop—adding permanent brown tones to the natural color variations. It is not possible to obtain complete uniform distribution of the shot grooves over the entire surface of the stone. Some portions will have only a chat sawed finish. A shot sawed finish can be applied to flat surfaces only and should be confined to the coarser grades. Direction of the grooves will be vertical and/or horizontal in the stone unless the direction is specified.

Due to changes in fabrication methods, the chat and shot-sawn finishes are no longer widely produced by the industry. Those interested in either finish should contact ILI or its member companies for information as to their availability.

H. CUSTOM TEXTURES: Many fabricators produce specialty textures, which may be linear or non-linear. Linear textures usually have parallel ribs and grooves. It is generally more economical to run textures the long dimension of the stone. The ribs and grooves may be quite smooth with a neat and tailored look, or rough and broken to produce a craggy, almost random appearance with an occasional area of “break-out” or “scoop-out” across the raised portions of the texture. These textures

This drawing shows the progressive stages of production in Indiana Limestone quarries and mills. The first quarry operation turns huge “cuts” at 90 degrees from their original position in the deposit (A). These cuts are first drilled, then split into blocks at the quarry. The blocks are then shipped to a mill where they are sawed in slab thickness (B) by belt saws, wire saws or gang saws.

Circular diamond saws, planers and various types of computer-operated fabrication machines further shape and dimension the slabs into panels and other building elements. Surface textures are usually produced in this stage of the operations.

See page 4 for photographs and more information on quarries.

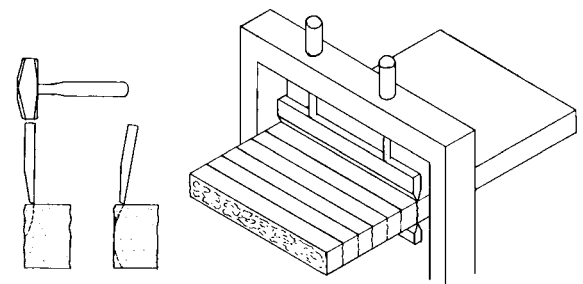
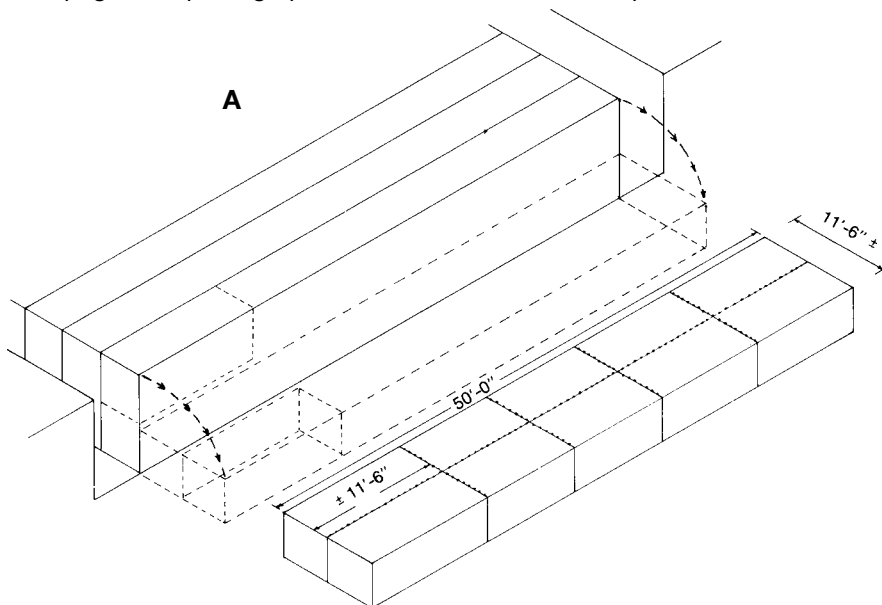

Typically, split face strip ashlar stone is produced on a guillotine.

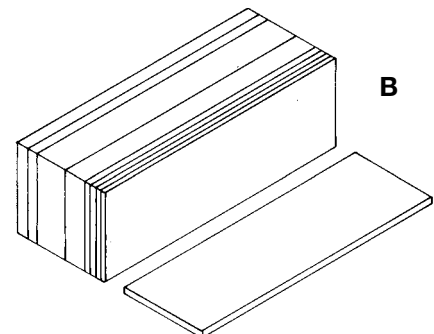

are well suited to the coarser grades of stone. Specific information may be obtained from any ILI member.

Note: Coarse and textured finishes are relatively expensive compared to those produced by planing machines. They are difficult to emulate, but rough surfaces without the moderate to heavy elliptical lines of chat and shot sawed finishes can be achieved by sandblasting.

how to use the indiana limestone grading system

The grades of Indiana Limestone can be used to advantage in developing good architecture at the lowest cost to clients. For instance, where stone is visible at close range, the grading system allows the architect to choose either a fine-grained material to achieve a monolithic look, or a coarser stock if his design favors a less formal look. Where stone selected for fine grain is used at eye level, a more textural material may be chosen for stone to be viewed at a distance. Because both the grading system and its final use by the architect are subjective, firm guidelines are difficult to establish. Still, sensitive use of the grading system will produce the design intent while allowing best use of budget dollars. ILI and its member companies will be glad to offer advice and guidance samples to aid the decision process.

Specifications for Indiana Limestone should be based on these descriptions and on the Grading Classifications listed on p. 10. Final selection and acceptance of material should be based on the Grading Classifications and the samples approved by the architect.

rock face

Rock face, sometimes called “pitch-face,” is a rough finish applied to a stone that has been dressed by machine or hand to produce a bold, convex projection along the face of the stone (pillow effect). The finish provides a bold, massive appearance.

The use of rock face has seen a resurgence in recent years. Designers relate to the bold, massive appearance of many older buildings such as courthouses, state and federal office buildings. Much of the rock face found on these buildings was hand pitched at the jobsite by the installer at the time of installation. Since this practice is no longer workable in modern construction, stones today are normally sawn to exact bed heights, hand-pitched both top and bottom beds, and shipped by the fabricator to the jobsite in random lengths for jobsite fitting. Shop drawings and anchorage in stone are not provided. Course heights normally range up to 1’-4”. This type of rock face is classified within the limestone industry as “standard product,” and is priced by the ton.

METHOD #1

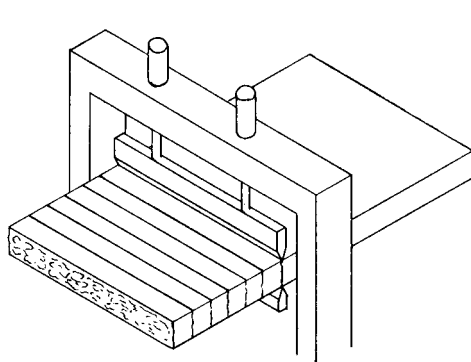

STEP #1

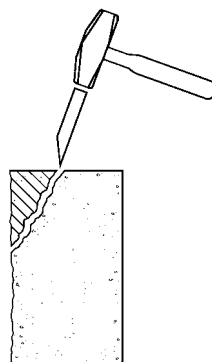

STEP #2

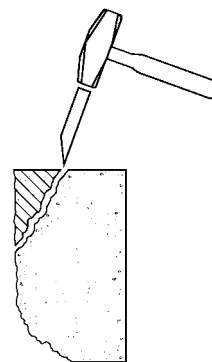

STEP #3

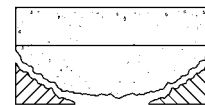

STEP #4

STEP #1—A stone slab is guillotined or broken into individual pieces by a machine.

STEPS #2 & #3—Individual pieces are hand-pitched top and bottom.

STEP #4—Face ends pitched only if cut stone.

METHOD #2

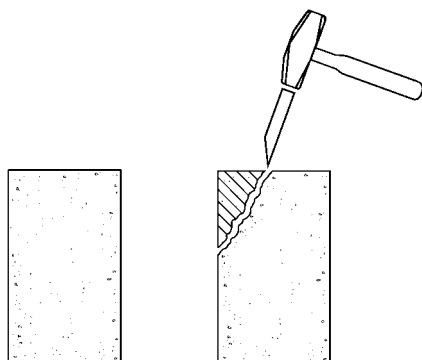

STEP #1

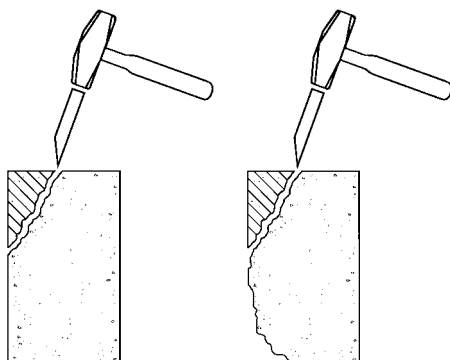

STEP #2

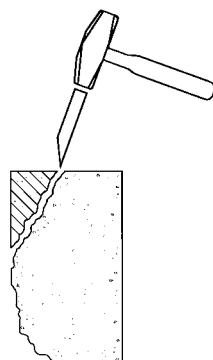

STEP #3

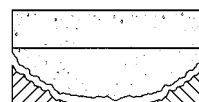

STEP #4

STEP #1—A stone is sawed-6-sides.

STEPS #2 & #3—A sawed-6-sides stone is hand-pitched top and bottom to obtain one piece of rock face.

STEP #4—Face ends pitched only if cut stone.

However, much of the rock face used today requires further work than that normally provided as standard product. In such situations, rock face might be classified as "cut stone." A few items which might cause rock face to be considered as cut stone are the following: cutting of anchorage; increased course heights; cutting to specified lengths; hand-pitching of both face ends; cutting of drips,

washes, corners, checkouts, holes, etc.; preparation of shop drawings; requirement of additional stock; etc. The Indiana Limestone Institute recommends the designer consult either with the Institute or a member fabricator prior to designing rock face stone. The sketches on this and the previous page indicate several methods used in fabricating rock face.

METHOD #3

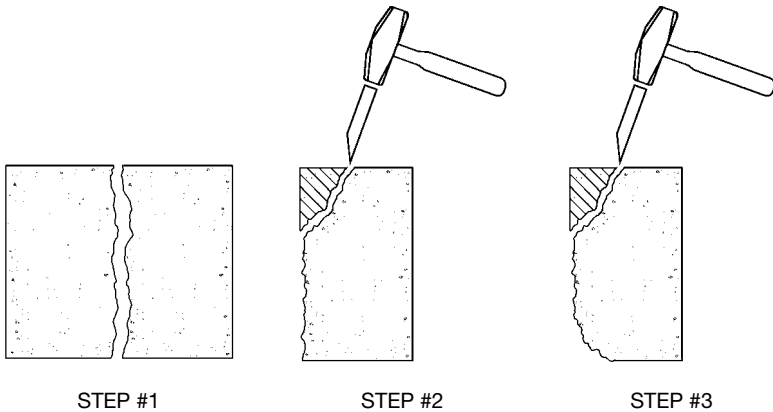

STEP #1—A sawed-6-sides stone slab is drilled and split to obtain two pieces of rock face.

STEPS #2 & #3—Each piece of stone is then hand-pitched top and bottom.

STEP #4—Face ends pitched only if cut stone.

METHOD #4

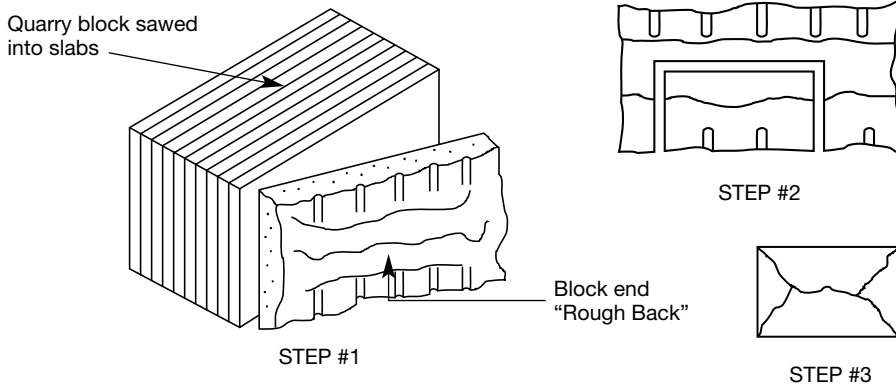

STEP #1—When sawing a quarry block into slabs the block end "rough back" can be used to fabricate a piece of rock face.

STEP #2—An individual piece of stone required for one piece of rock face stone is cut out of a rough back.

STEP #3—Stone is hand-pitched top and bottom and both ends to obtain a piece of rock face (cut stone).
—See sketches above in methods #2 and #3 for typical hand-pitching.

The following table is a general guideline for the additional stock typically required to produce rock face. As noted above, the amount will vary from company to company.

STONE HEIGHT	NORMAL PROJECTION
0" to 6"	1" to 1 1/2" ±
6" to 1'0"	1 1/2" to 3" ±
1'0" to 1'6"	3" to 5" ±
1'6" to 2'0"	4" to 6" ±
2'0" to 2'6"	4" to 6" ±
2'6" to 3'0"	Stones this height probably obtained from rough backs only Projection varies -3" to -9"
3'0" to 3'6"	
3'6" to 4'0"	
4'0" to 4'6"	
4'6" to 5'0"	

NOTE:

- Harder stones are usually easier to pitch than softer stones.
- Stone grain should be vertical.
- Larger course heights are more difficult to produce.
- Designers should realize that showing large course heights with small projections is unrealistic. The fabricator will increase the thickness to whatever thickness is required to produce the stone.
- Actual stone thickness will be irregular due to variations in stone breakage.



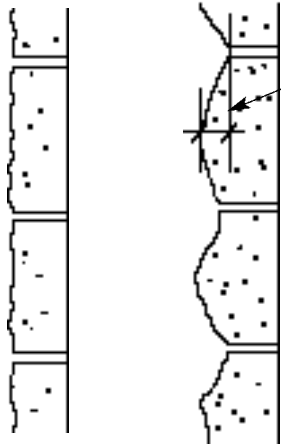

Incorrect section

Correct section

Use table to determine the approximate projection required for course height.



Miter Joint
(Internal corner)



Butt Joint
(Internal corner)

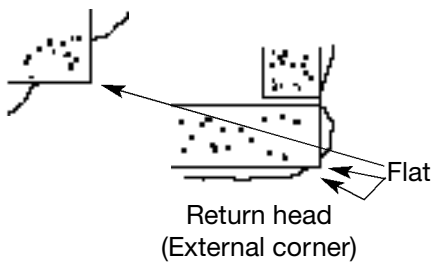

Return head
(External corner)

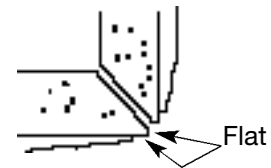

Quirk Miter
(External corner)





PANELS

SINGLE STORY CONSTRUCTION

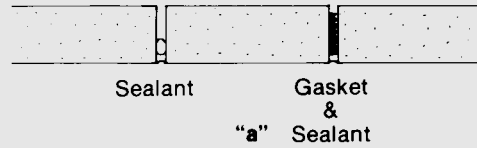
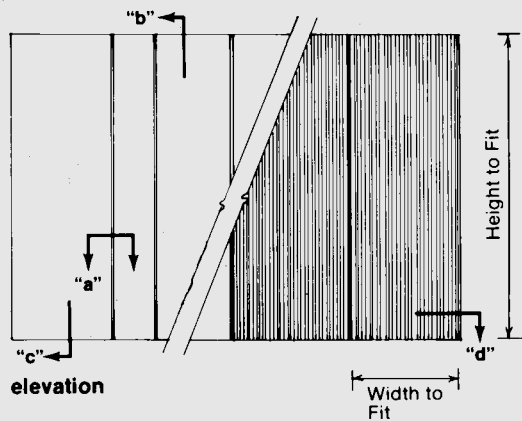

- Limestone panels used in this manner represent an effective means of obtaining a "monolithic" design for one story applications at a minimum cost.

- Panels are normally anchored at top and bottom with no mechanical anchorage at the vertical joints—thereby creating a flexibility whereby the panels can easily be removed and reused if building is expanded.

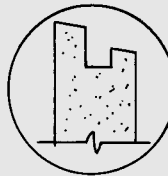

Note: Surface to be covered by flashing should be parallel to but in a lower plane than uncovered surface. This prevents flashing and sealant buildup from damming moisture.

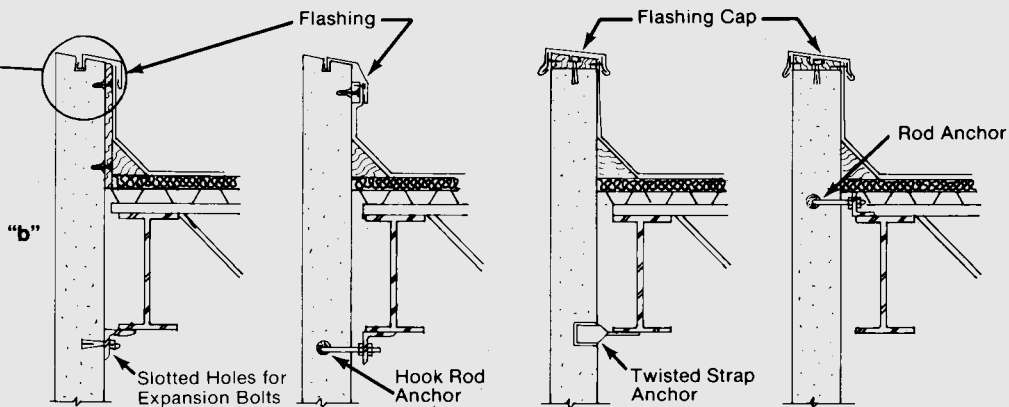

anchorage at top of panel

Various methods of anchoring top of panels to structure. See p. 18 for parapet windload calculations.

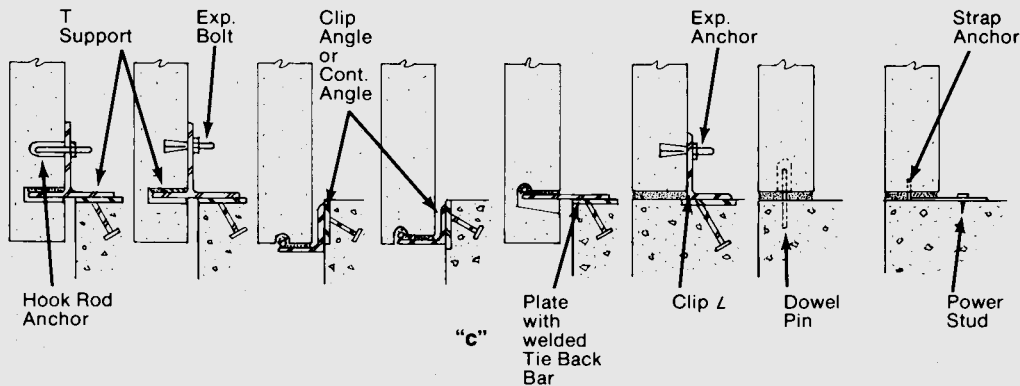

Note: In using expansion bolts as tie backs, refer to manufacturer's instructions regarding distance to any edge, and distance from center-line to center-line.

base connections

Note: See p. 21 for shim details.

PANELS FLOOR TO FLOOR



Indiana Limestone panels to span floor heights are commonly used where the design requires these applications. In many such cases, no backup material is required and interior walls may be set on metal studs or against rigid insulation on the stone backs themselves. Anchor systems detailed here and elsewhere in the Handbook may be used. For engineering requirements, see p. 15 for panel size limitations; p. 16 for windload specifics and p. 20 for angle and plate load limits.

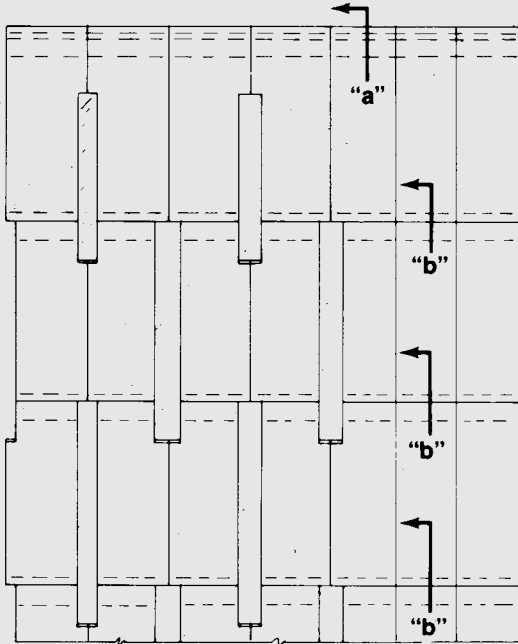

partial elevation

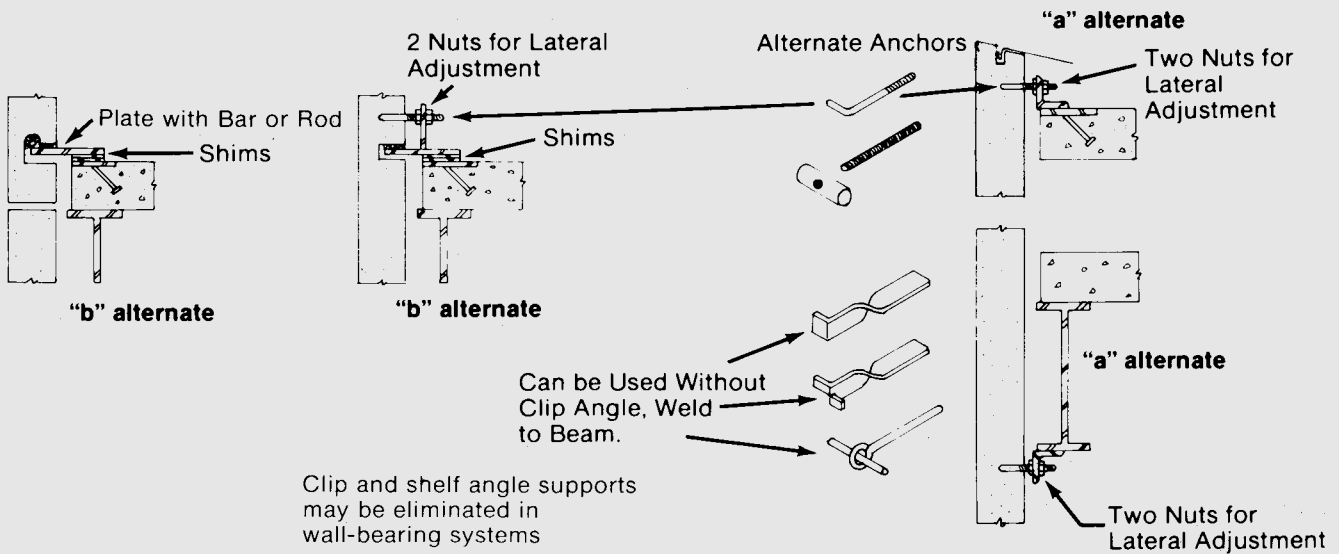
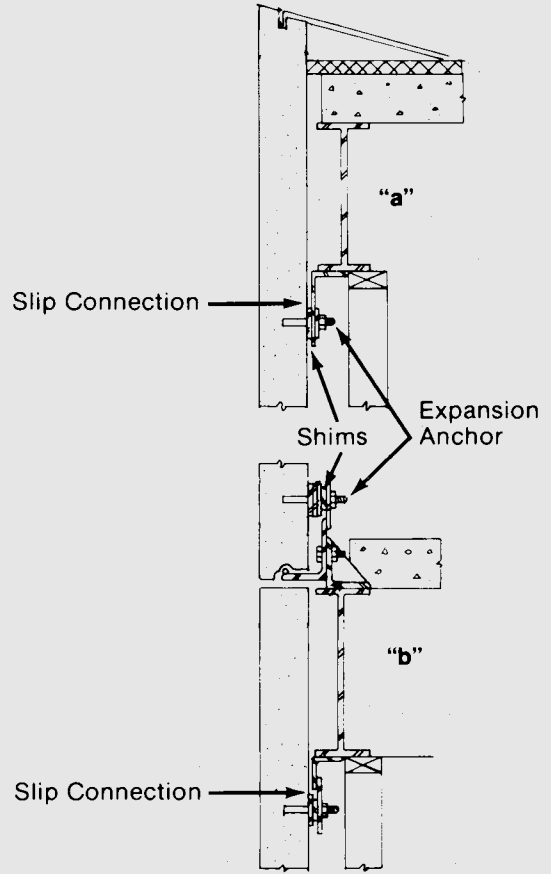



PANELS GRID SYSTEMS

Metal grid or strut systems provide increased flexibility in stone erection procedures in both new and refacing construction, and allow an improvement in closing time in certain building types. The grid system is a support framework which may eliminate the need for masonry backup. It allows the use of thinner stone of smaller face area in circumstances where windload requirements would otherwise demand thick, floor-to-floor panels. These systems are proprietary, and specific information on them is furnished by their manufacturers. ILI shows here the general design and procedures common to grid systems, and will furnish the names and addresses of manufacturers on request.

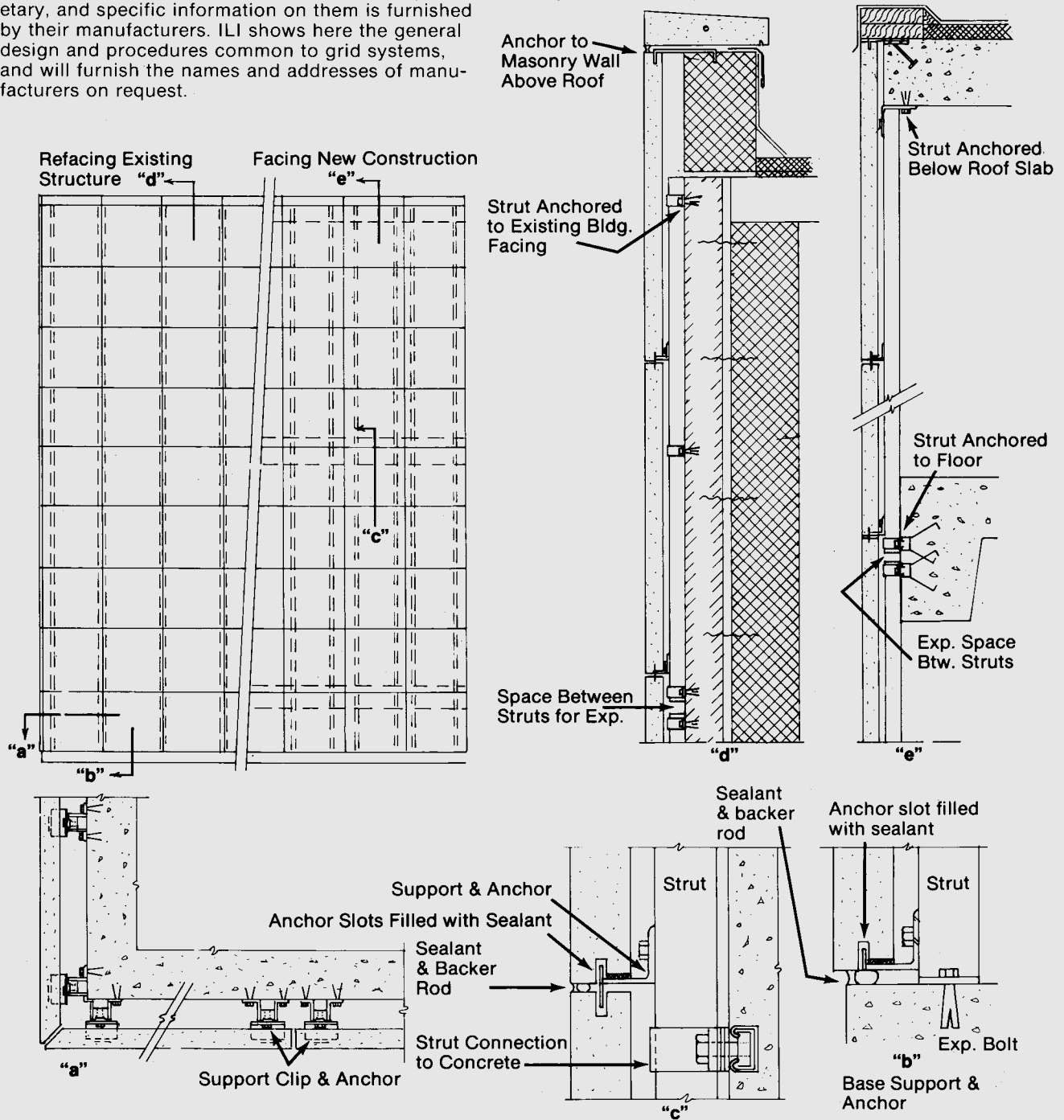



PANELS

POST TENSIONED ASSEMBLIES

Post-tensioned assemblies in both panel and beam configurations have been used for years to obtain the advantages of Indiana Limestone's weatherface for those applications where longer-than-normal spans are required.

The post-tensioned units typically are made of multiple stones joined by thermo-setting adhesives and secured by tensioning tendons drawn through matching holes in the stones' lengths.

Design loads on system end-plates are assured by factory supervision and control. Plates are typically sunk below the assembly's end-joint surface. Tendons are rods, and end connections may be bolts or other positive fittings. Tendons are typically grouted in.

Post-tensioned assemblies are often supported at columns only, to relieve deadload on floors. Such assemblies can be designed to accept windloads for all building elements.

The dimensions shown in this example will vary according to the requirements of the project.

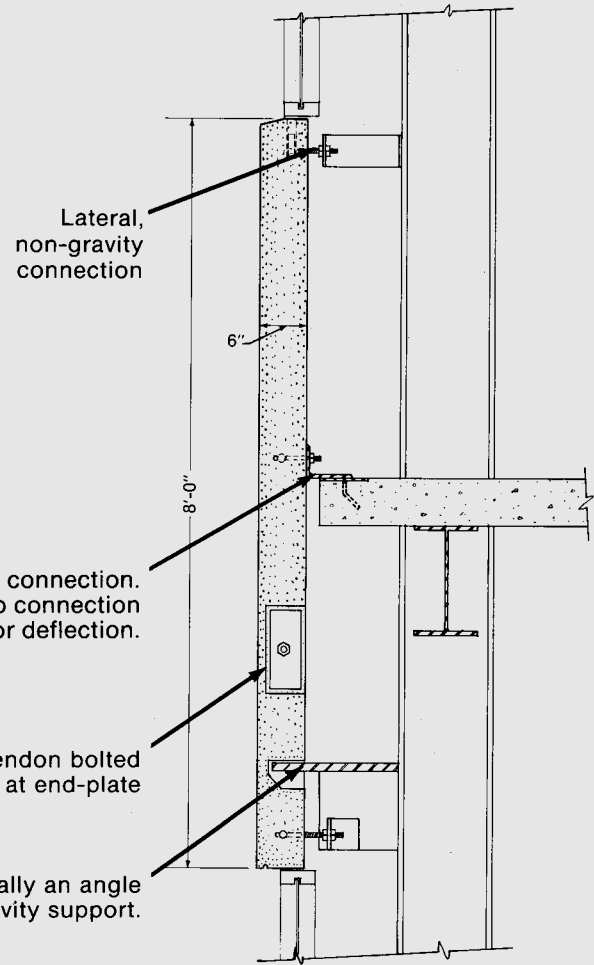

Lateral connection.
Should be designed as slip connection
to accommodate floor deflection.

Tendon bolted
at end-plate

The bottom connection is typically an angle
or plate for gravity support.

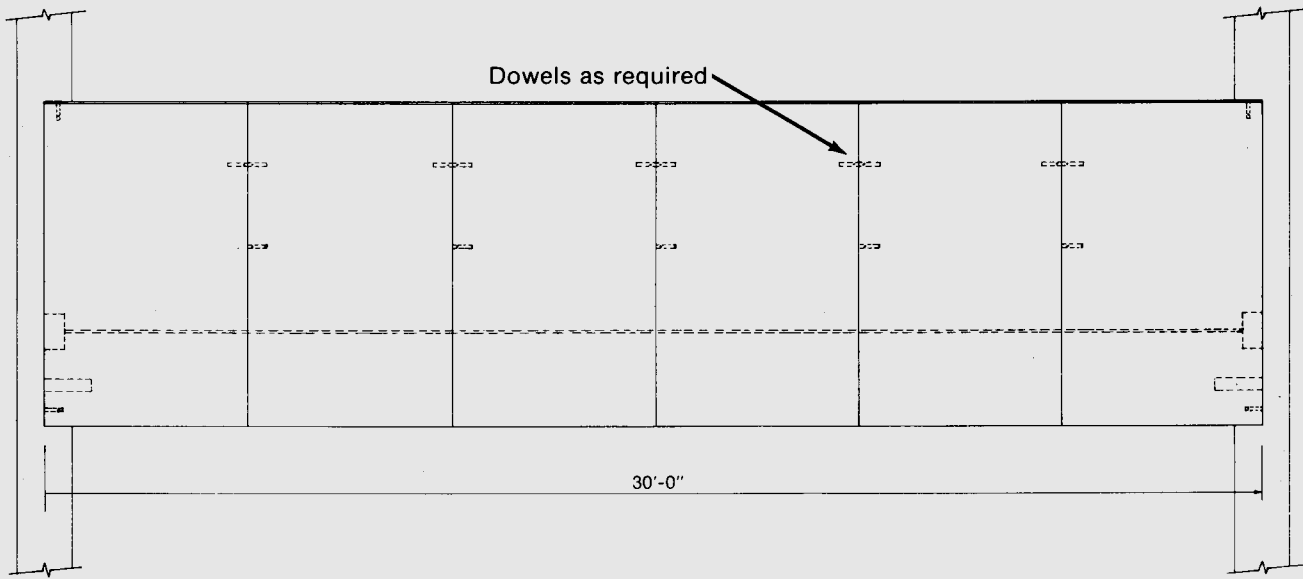



PANELS

ANCHORAGE TO EXISTING BUILDINGS

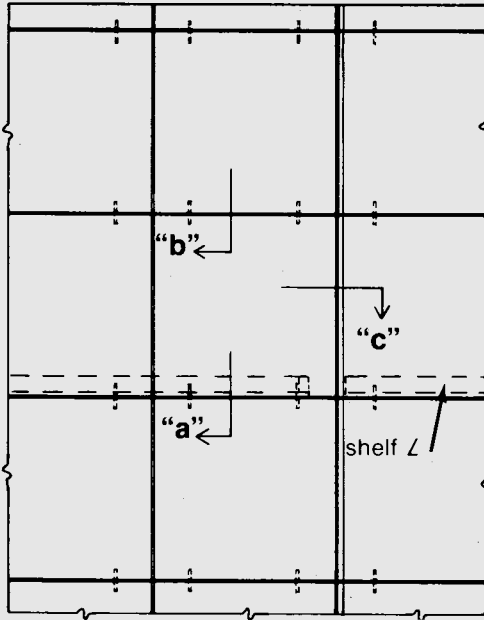

- Indiana Limestone produced to a thickness of 3" is commonly used for refacing old masonry buildings.
- In cases where all projections on the old structure are cut back to the wall line and the windows filled with masonry to form a backing, the new stone facing can be easily installed over the old wall by anchoring and supporting as shown in details. The designer should determine which method below best applies to the condition of the existing building.
- Vertical adjustment slots should be provided in the vertical leg of the angles to engage the attaching bolts set in the wall. Slots permit final alignment of the angles with the stone.

partial elevation

Note that continuous shelf angles (detail "a") should be used to structurally support the stone at vertical intervals approximating the floor spacings.

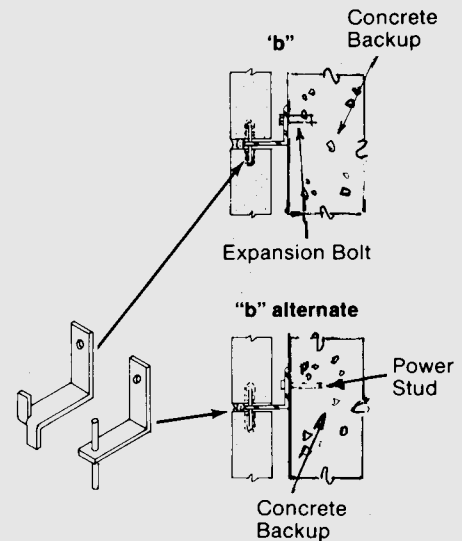
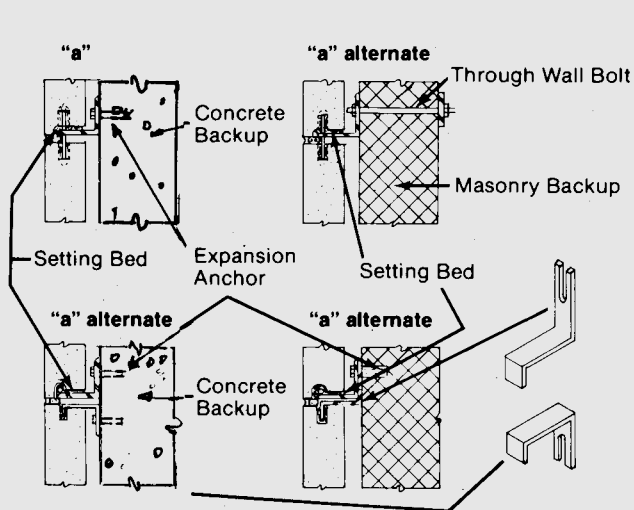
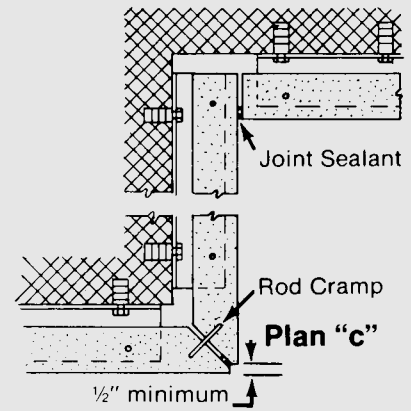



PANELS

MULTI-STORY CONSTRUCTION ANCHORAGE TO STEEL FRAME WITHOUT MASONRY BACKUP – TWO CONNECTION SYSTEMS

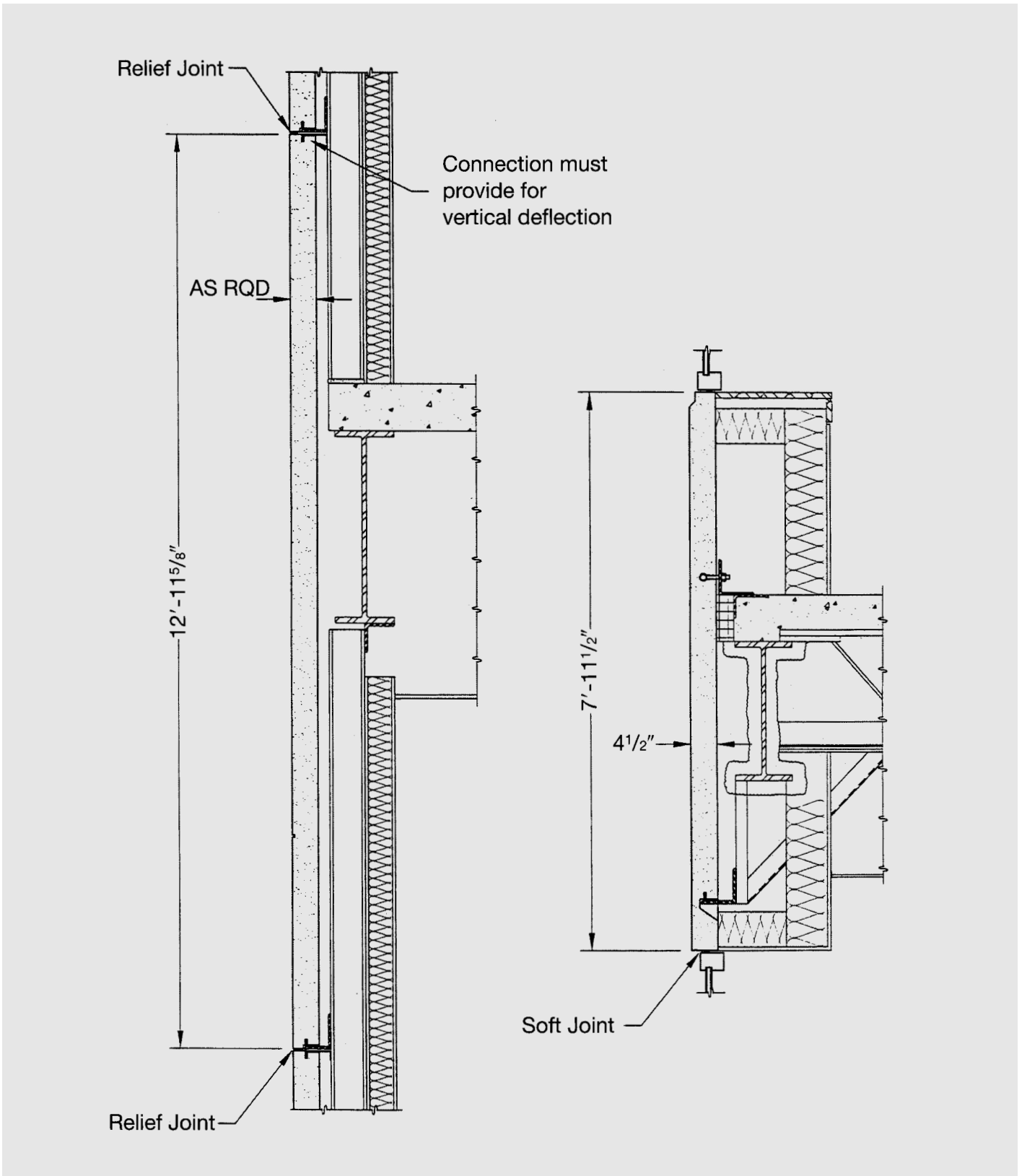



PANELS

MULTI-STORY CONSTRUCTION ANCHORAGE TO STEEL FRAME WITH MASONRY BACKUP

For additional coping info. see pg. 69.

There is little difference between anchoring stone to either a steel or concrete frame. Pages 59 & 60 show details which are representative of many possible ways to support and anchor stone panels and are not meant to suggest that all methods be used on a single building. For simplicity in construction, the designer should use as few type anchors as possible.

Note: For Intermediate Anchorage see pg. 17.
For additional support methods see pg. 21.

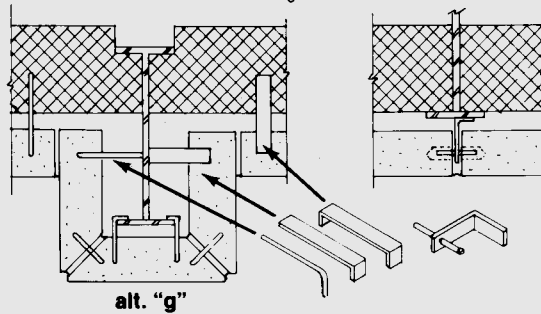
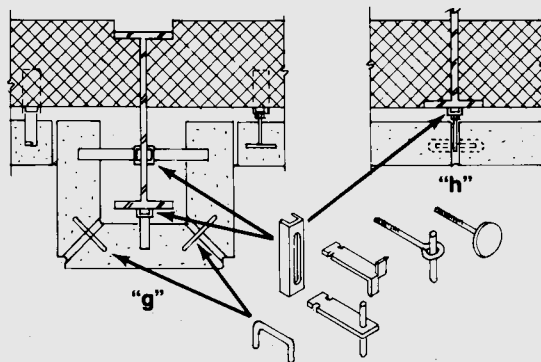
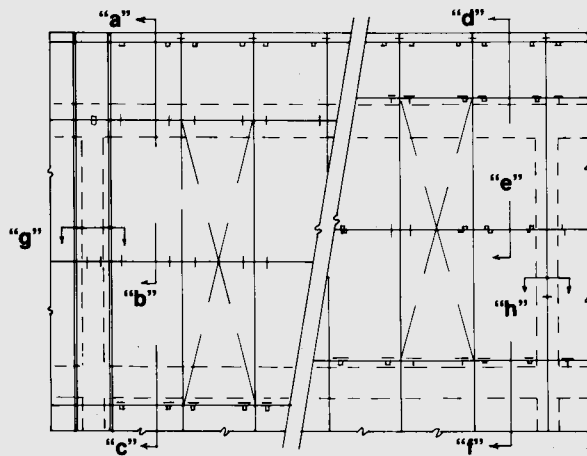

Anchors shown are at Horiz. Joints only.

Note: It is permissible to pierce blocks to insert anchors. Block must be dammed and well-filled with grout.

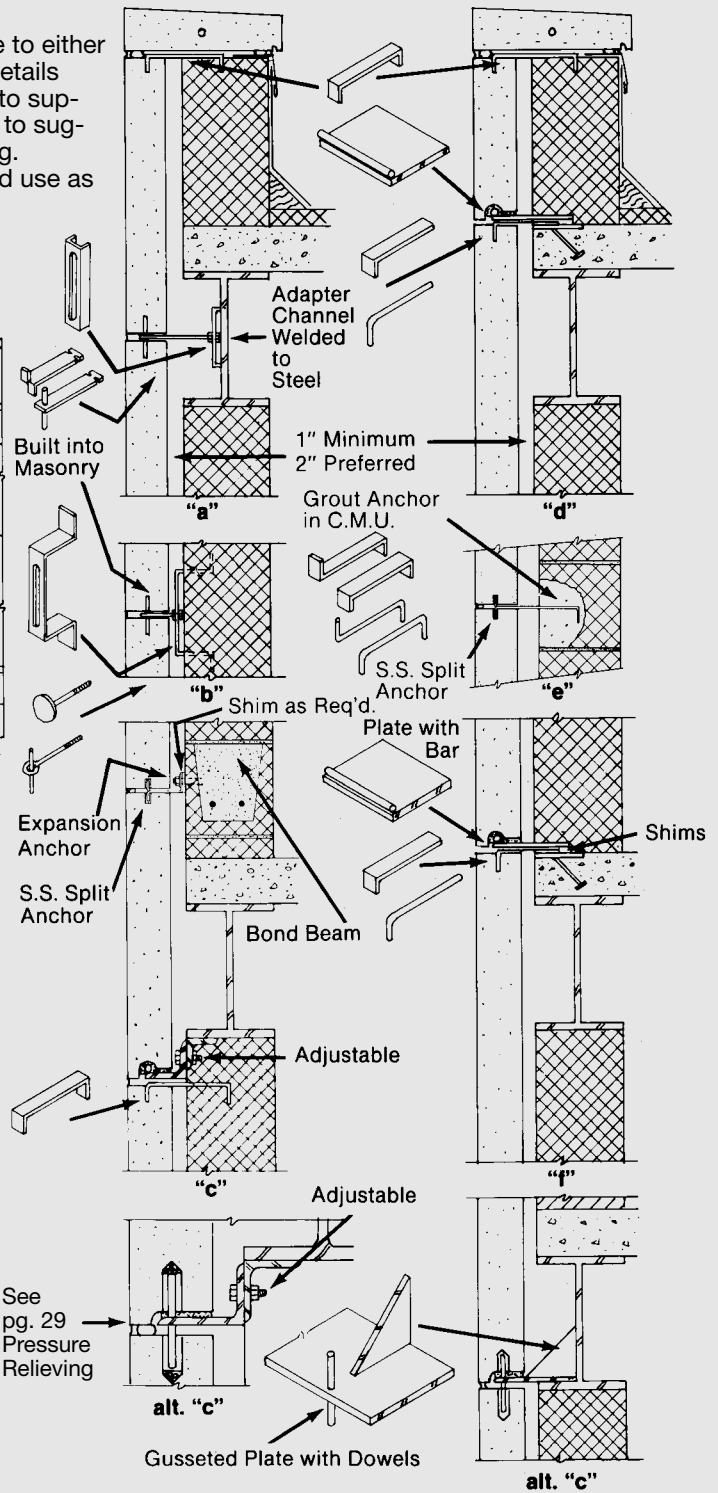



PANELS

MULTI-STORY CONSTRUCTION ANCHORAGE TO CONCRETE FRAME

In multi-story construction, limestone panels should be structurally supported at vertical intervals not to exceed the floor spacings. The preferred method of supporting such panels is by attaching a projected structural member (angle, plate) to the building frame. This method allows for all panels to be of similar thickness, thus giving uniformity to both fabrication and setting methods.

Note: For Intermediate Anchorage and additional anchor information, see pp. 17-19.

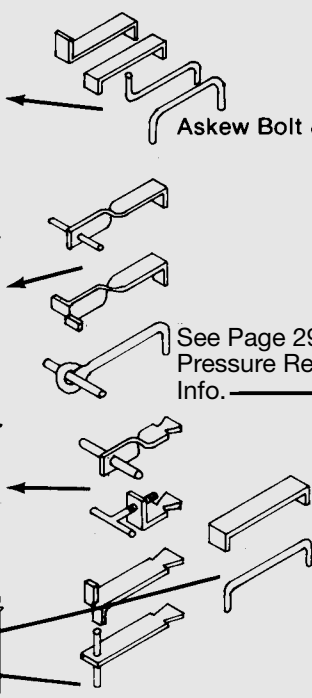
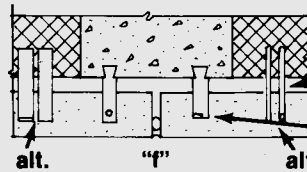
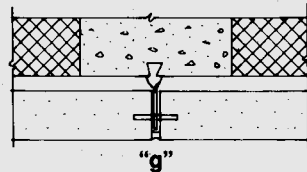
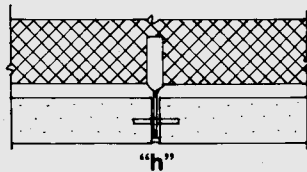
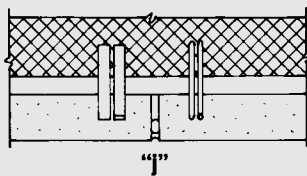
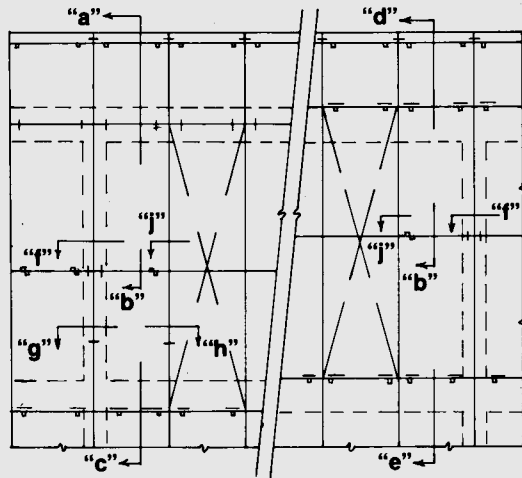

See Page 29 for Pressure Relieving Info.

For additional coping info. see pg. 69.

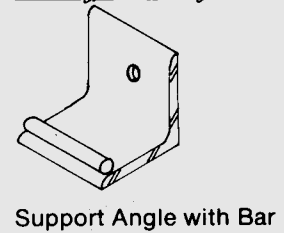
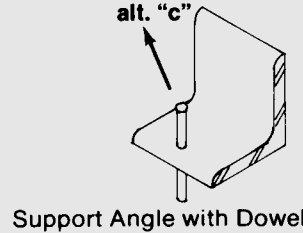
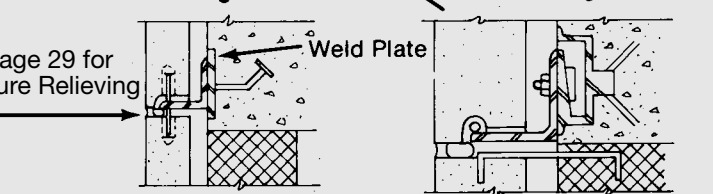
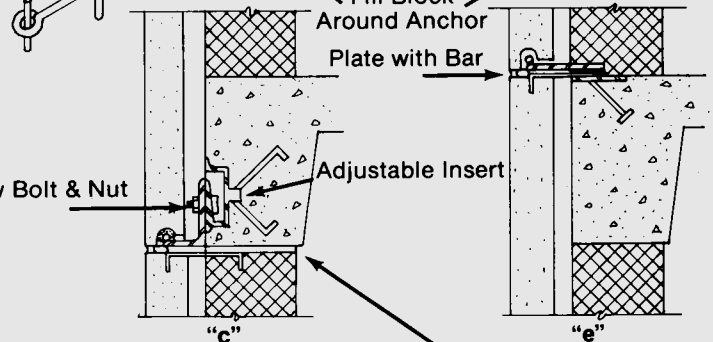
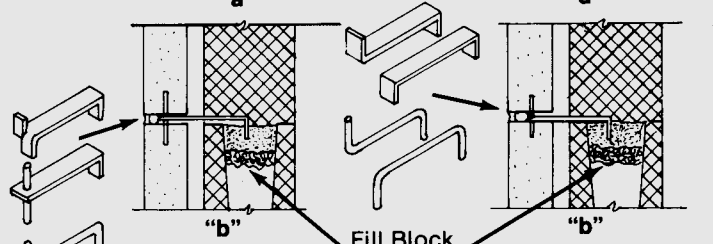
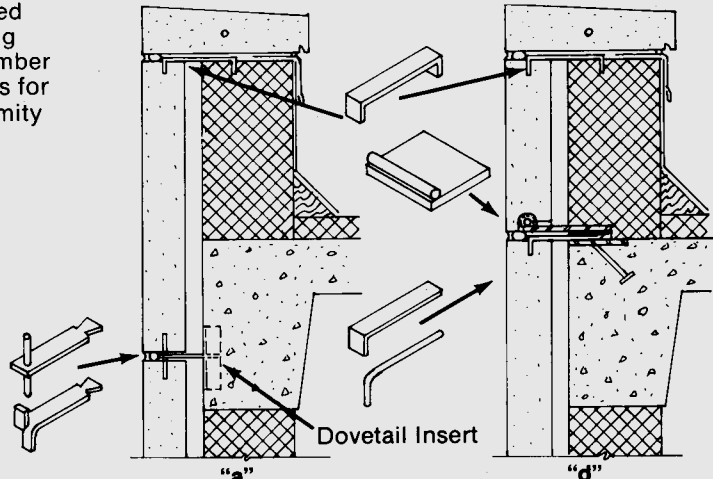



PANELS

LINER BLOCKS SUPPORTS

As a general statement ILI recommends that gravity support be accomplished with conventional shelf angles (or similar devices) located either at the bottom bed or at shelf checks in the lower part of the panel. See the examples on page 21. However, in some cases, configurations of either the stone or the supporting structure may indicate that epoxied limestone liners might be appropriate as a method to carry gravity or retention loads. This is especially true in the case of thin panels where the bottom bed will be exposed and where conventional shelf checks of sufficient depth cannot be made without creating a thin and potentially fragile “shell” at the face of the panel.

But, it should be noted that when the added costs, added production time and other factors associated with epoxied liners are considered, the use of thicker stone that would permit use of more conventional shelf angles while adding only a relatively small amount of weight may actually be a better choice.

For those cases where the use of epoxied limestone liners will be considered, ILI offers the following suggestions and recommendations:

Even with the use of liners, ILI does not recommend the use of Indiana Limestone in thickness less than 2”.

Liners should only be installed at the mill by experienced shop personnel using appropriate procedures.

Liners are critical elements and should be designed, sized and specified by designers experienced with natural stone properties and characteristics using appropriate design procedures, test data and performance information.

The epoxies used should be as specified for the particular application and should be used in accordance with the epoxy manufacturer’s recommendations. The epoxy manufacturer should be experienced in producing epoxies for use with natural stone materials.

Typically, liners should be at least 2” thick and will have a height to thickness ratio of between approximately 3 to 1 and 5 to 1. They may be short lengths located at gravity shelf locations — for instance, at fifth points or near the outside edges of the panels — or they may extend across the width of the panel less a small amount — often about 1” — at each end.

The epoxy bond between panel and liner should not be relied upon and stainless steel deformed or threaded rods should be installed as part of the liner assembly to transfer loads from the panel to the liner. They should be set at an angle so that they are, to some extent, “self-tightening.” These rods should be set into fully epoxied holes. They should engage the full thickness of the liner but should not come too close to the exposed face of the panel, as spotting or spalling at the face might occur.

Some engagement of the support angle into a pocket in the panel itself is recommended so that there is not sole reliance on the liner.

When liners are used, “stacking” of panels should be avoided or kept at a minimum to minimize gravity loads.

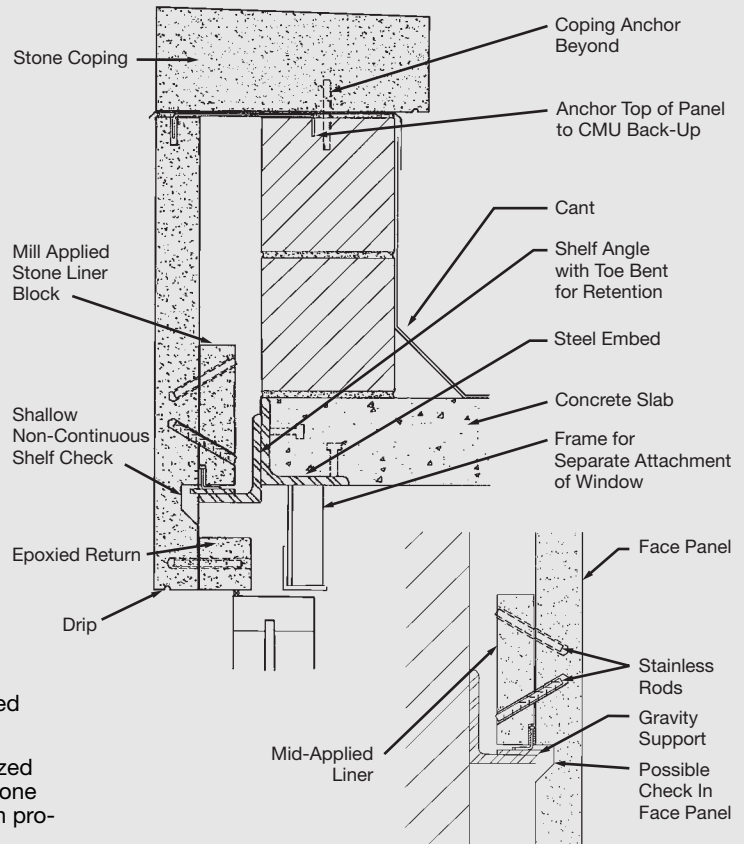

Typical Liner Detail

Also designs should be avoided that might transfer unintended and unplanned loads into panels and the liners through connection points, hard joints or other paths.

Liners — even if continuous across the back of the panel — should be designed and specified to carry gravity load at two points. These design load points should be symmetrical and preferably at fifth points or beyond.

It is recommended that liners be located near the bottom or at least in the bottom third of the panel. In most cases this will provide better stress patterns in the panel.

Support points at an epoxied liner are typically farther behind the center of gravity of the panel than if those supports were located directly under the panel or in pockets in the panel. This added eccentricity induces additional bending stress in the panel at the liner location. This eccentricity and bending stress must be comprehended in the design process.

For simpler design and installation, it is usually best to have retention points located near gravity support points. As a general rule liners may also be rebated on the bottom inside edge to form a slot for use for retention anchorage, as for wind loads. These retention loads should be considered in design.



TYPICAL DETAILS

ANCHORING TO CMU BACKUP

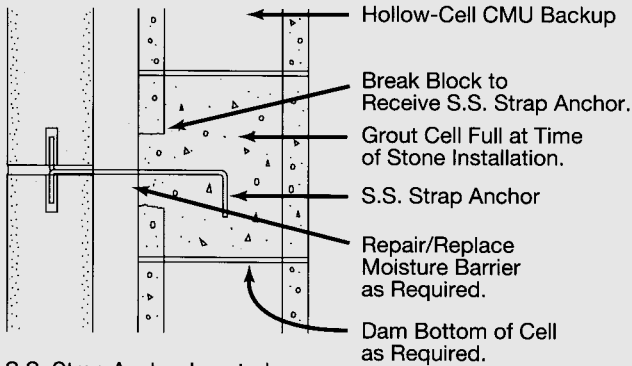

S.S. Strap Anchor Inserted into Broken CMU and Secured by Grouting Cell Full.

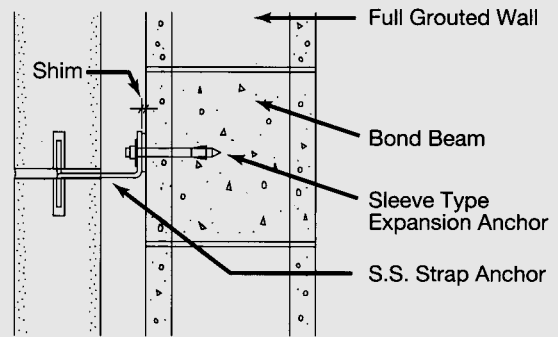

S.S. Strap Anchor Expansion Anchored to Solid CMU.

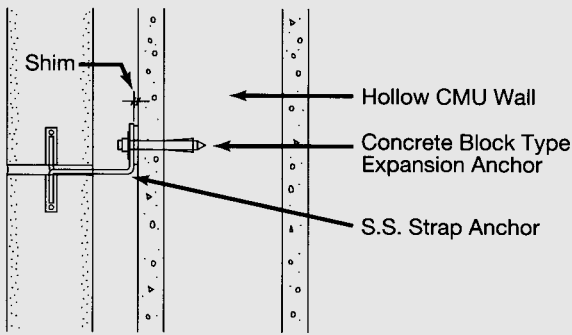

S.S. Strap Anchor Expansion Anchored to Hollow CMU.

Note: Use This Type of Anchor at Light Loads Only.

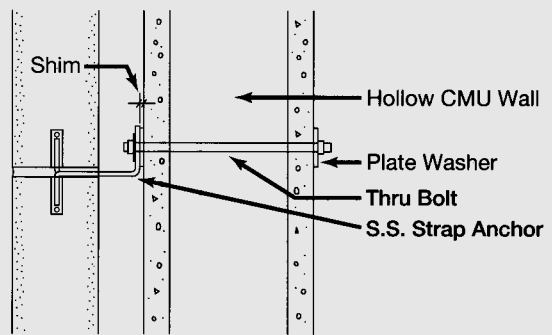

S.S. Strap Anchor Expansion Anchored to Hollow CMU.

Note: Use This Type of Anchor for Heavy Loads.

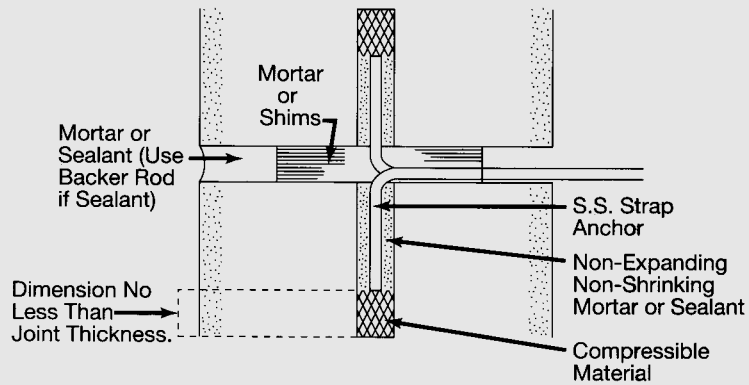

Suggested Treatment of Anchor Slot



TYPICAL DETAILS

STEPS AND PLATFORMS

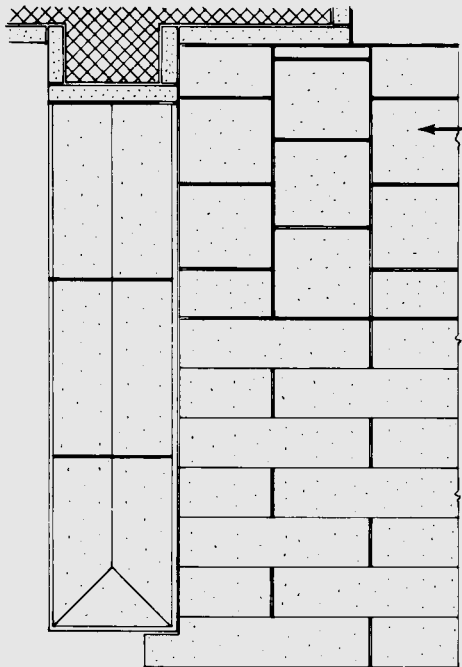

plan of steps



elevation

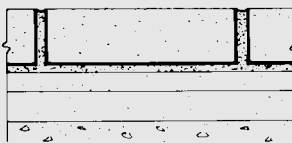

Stone paving and steps should be protected on all unexposed sides.

2 Basic Designs for Platforms

Uniform Pattern
Random Pattern

Do not build steps or platform under cheek walls (also see note below on expansion joint)

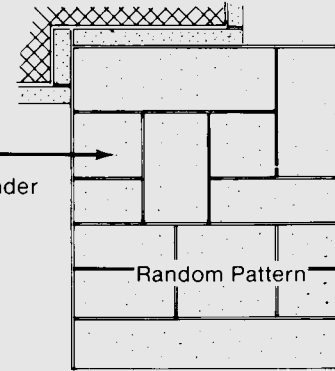

Random Pattern

Note: It is imperative that all precautions should be taken at time of construction to prevent future staining. The most important are
 (1) Adequate dampproofing on slab
 (2) Low alkali mortar
 (3) Dampproof stone (backs & joints)
 (4) Adequate drainage (slopes & weepholes)

2 1/4" Minimum Recommended
 1" Minimum
 1 1/2" Preferred For setting bed

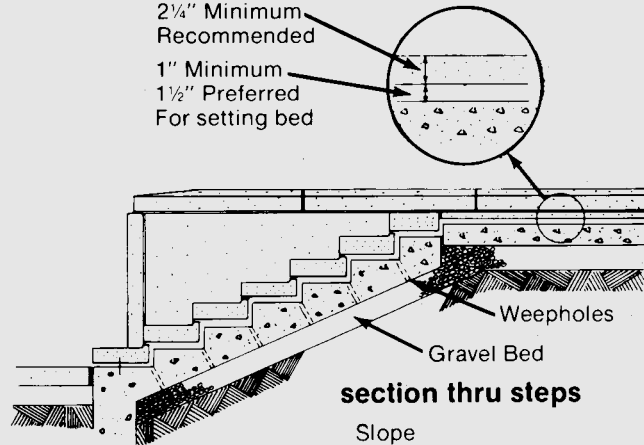

section thru steps

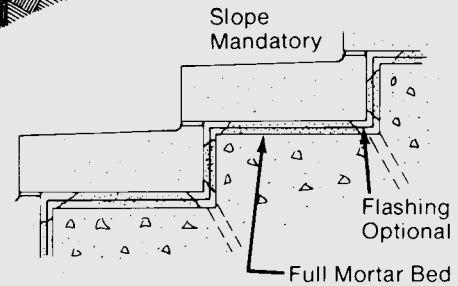

Slope Mandatory

Flashing Optional

Full Mortar Bed

Design Factors:

- Provide expansion joints between steps and cheek walls to permit thermal movement. Also permits steps to be set last, avoiding construction traffic. Also provide expansion joints at appropriate intervals within the paver field.
- Provide weepholes below steps and proper drainage below slab.
- Dampproof face of all concrete or concrete block to prevent staining.
- Stone used for steps and platforms should be specified in accordance with Note C, Table II, Page 8.
- When no safety tread is used, specify a light bush hammered or other safety finish.

Note: NEVER use salt for any purpose on or near stone.

See pp. 8 and 30 for additional information.

Also see "flooring and paving with Indiana limestone" pp 32 and 33.

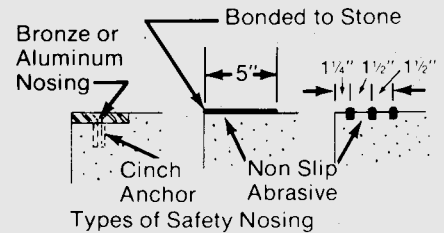

Types of Safety Nosing

TYPICAL DETAILS

WINDOW ELEMENTS



standard treatment of window elements

- Purpose of this plate is to give some guidance for the use of Indiana Limestone as window trim. All information shown is of a general nature & is applicable to most all situations.
- Obviously with the many types of sash manufactured (plus custom designs) it becomes impossible to show the almost infinite number of possible conditions one may encounter. Limestone being a versatile material offers many design possibilities which could be shown.
- Thus these details show general design criteria to be observed, and are not meant to limit the choice of design.

Note: The most important consideration when using limestone at windows is complete co-ordination with type & design of sash chosen. It is essential that architects details are of size & clarity to adequately show the relationship of stone to sash or frames being used.

2 types of sills

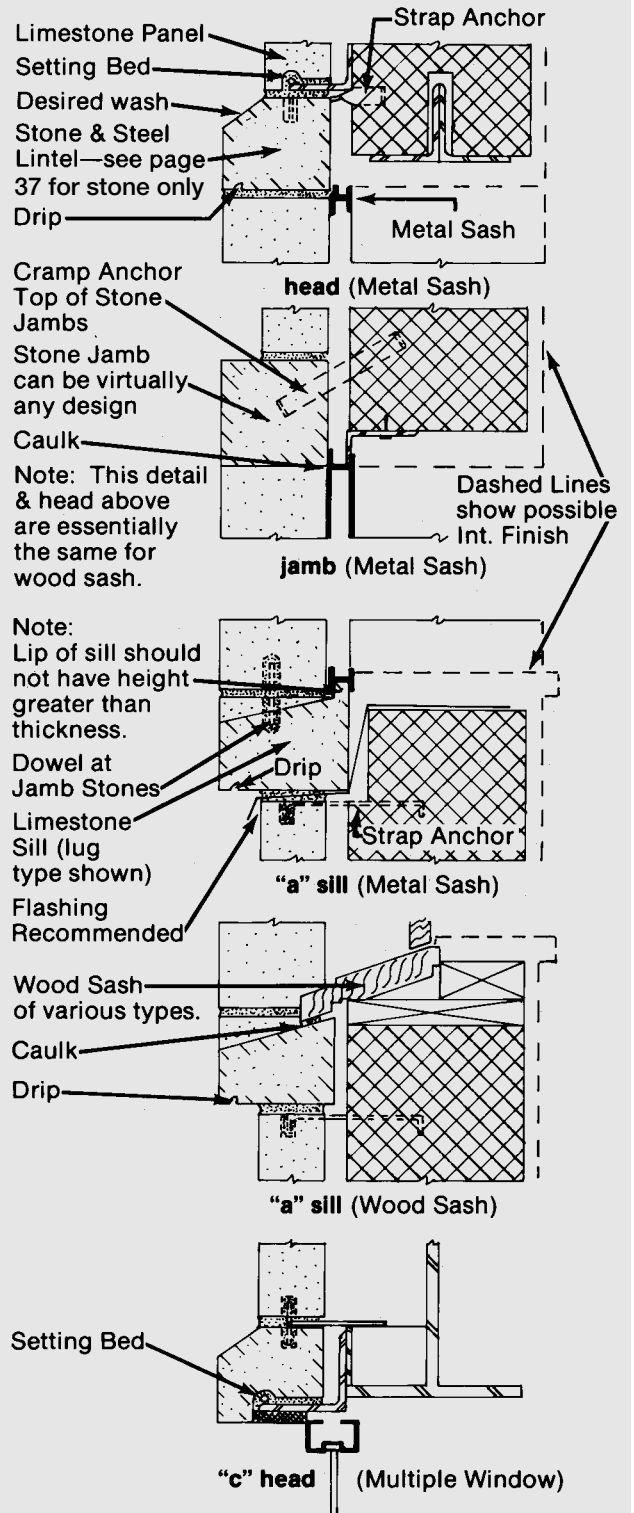
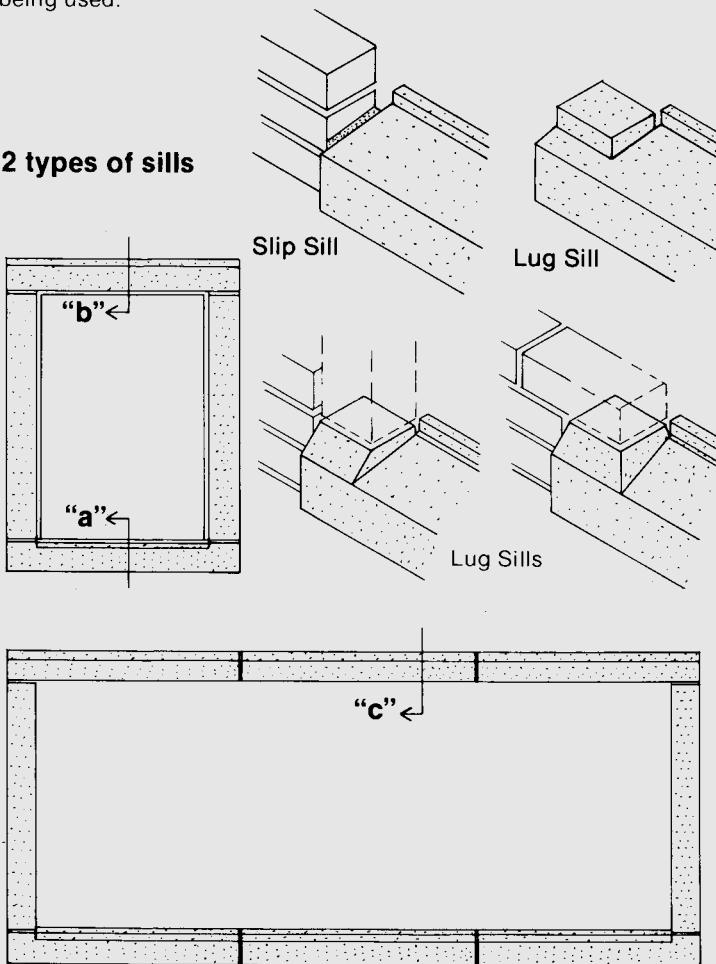



TYPICAL DETAILS

WINDOWS AND DOORS

limestone lintels

If correctly designed, lintels of Indiana Limestone may be used to span window & door openings with no additional support (steel) required. Of course the key to design is adequate depth & thickness to support the load above. Refer to p. 37 for lintel tables.

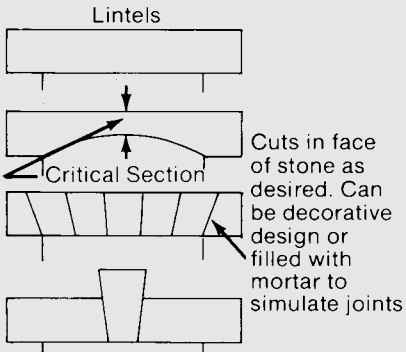

Because of its monolithic character & ease of fabrication the design possibilities of limestone lintels are almost unlimited. Shown are 4 examples. Shape & surface decoration may be varied to meet the architect's desires as long as the critical cross section area is maintained.

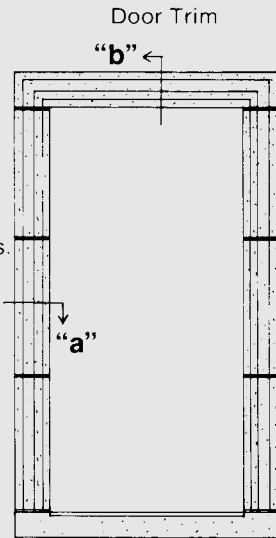

door trim

Limestone trim may be used to emphasize doorways in much the same manner as window treatment shown below. Shown are 2 examples of an almost unlimited number of designs possible with stone.

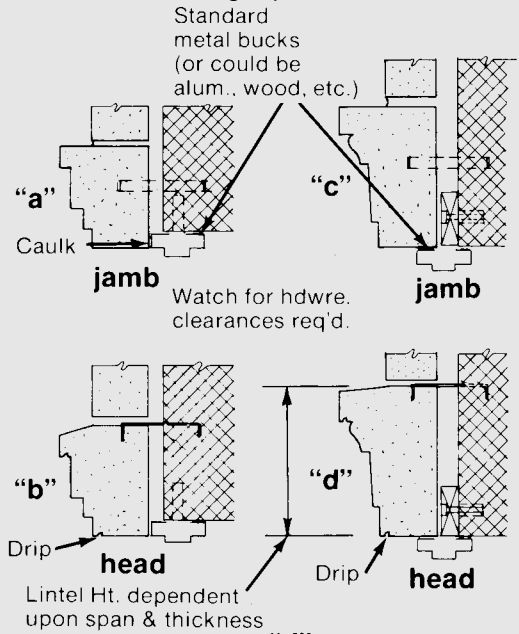

sun shading devices

Here again we have almost unlimited possibilities for the economical use of stone. Not only do such treatments (vertical or horizontal fins) add to the attractiveness of the building facade, they also help reduce the air conditioning load.

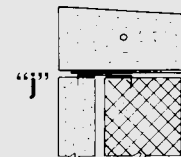
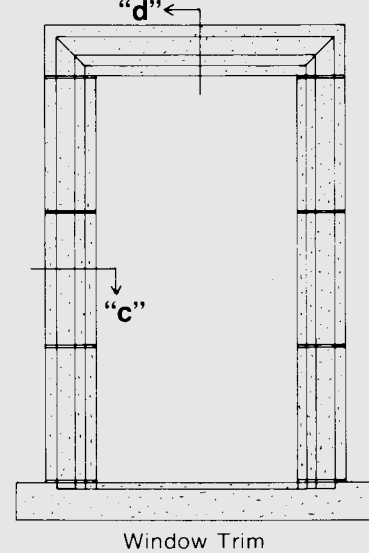
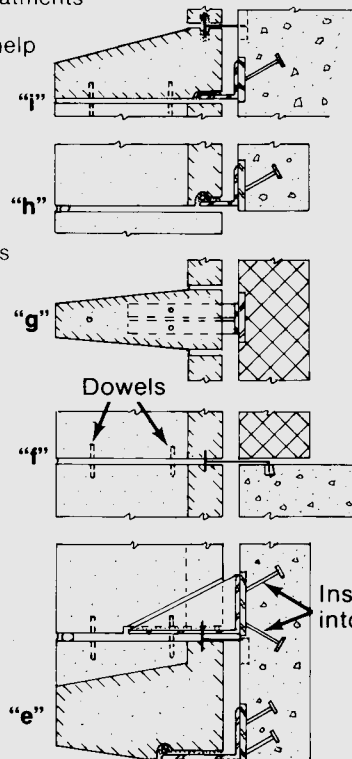
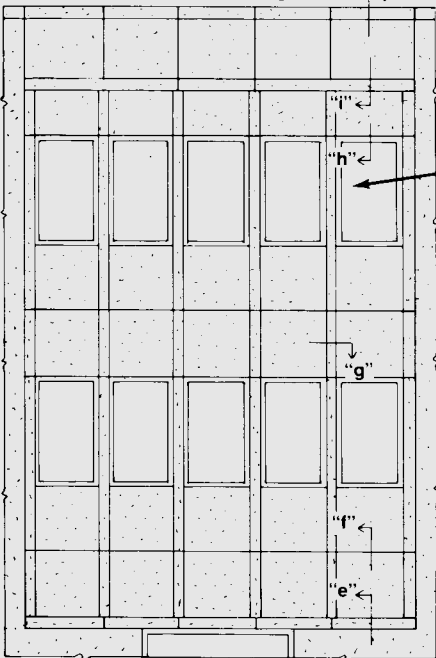

TYPICAL DETAILS TRADITIONAL DOORS

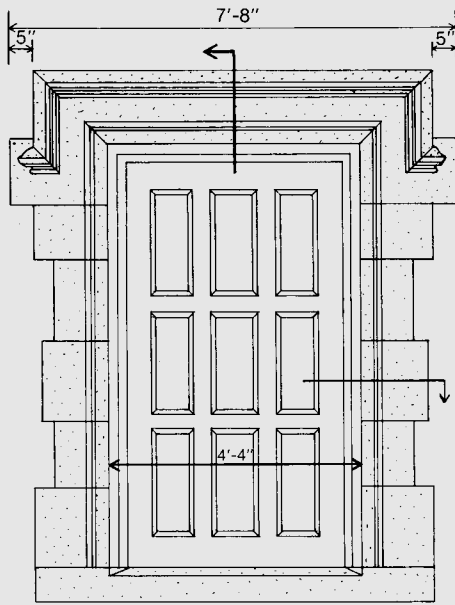

elevation

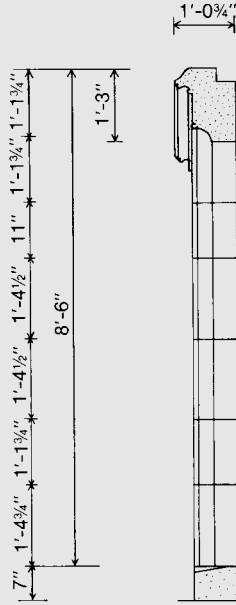

section

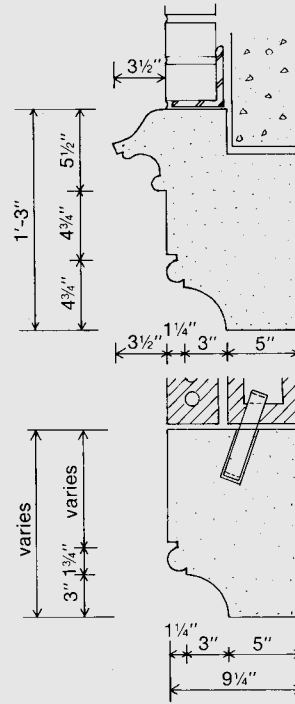

header section

jamb plan

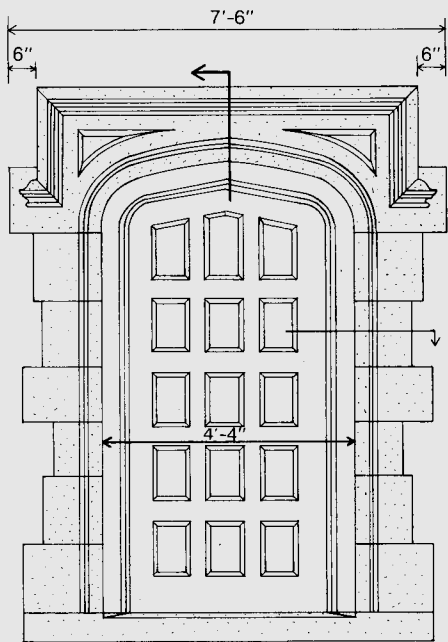

elevation

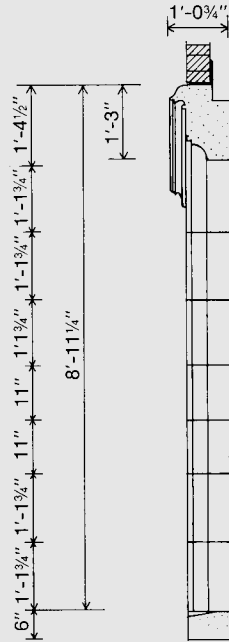

section

Shown are but two of the many designs available using limestone to accent doorways.

Dimensions and design are custom coordinated to each individual architectural desire.

Limestone can be used as interior trim, as well as exterior or can be cut in one piece to satisfy both conditions, thereby eliminating unnecessary joints.

Consult with the fabricator concerning intricate moldings and carvings. Slight changes in design can reduce fabrication cost.



TYPICAL DETAILS

TRADITIONAL CORNICES

typical cornice detail

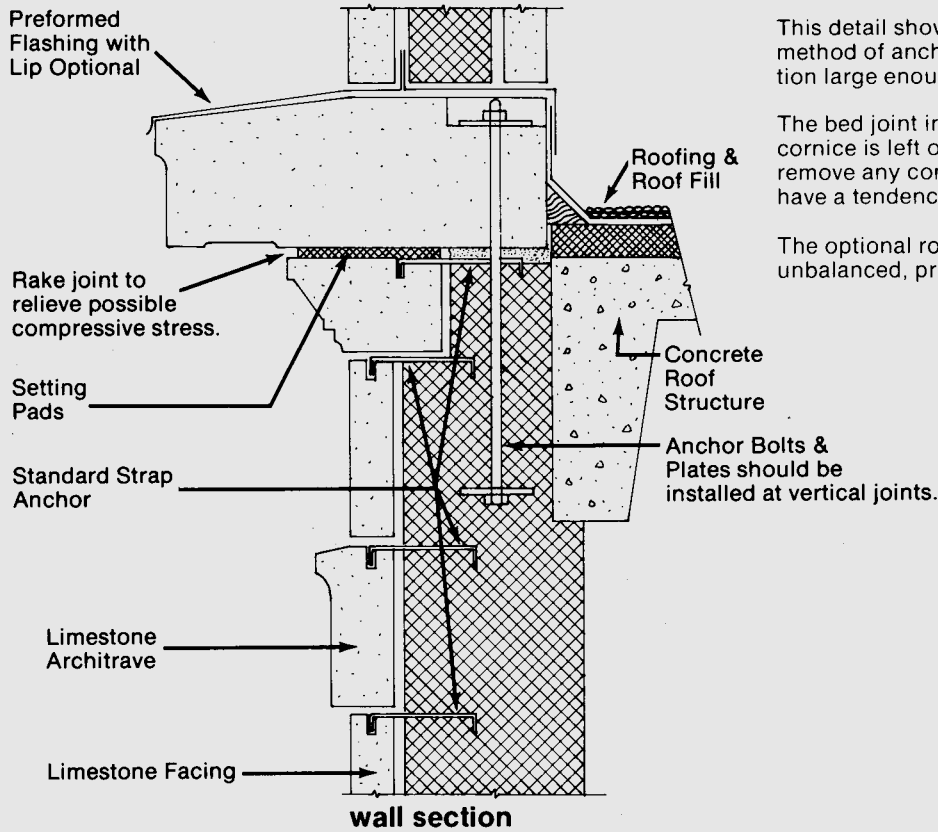

This detail shows the most commonly used method of anchoring a cornice with a projection large enough to be unbalanced in the wall.

The bed joint immediately below the heavy cornice is left open back far enough to remove any compressive stress which would have a tendency to break off stone below.

The optional rod-and-plate tie-down stabilizes unbalanced, projecting courses.

traditional cornice

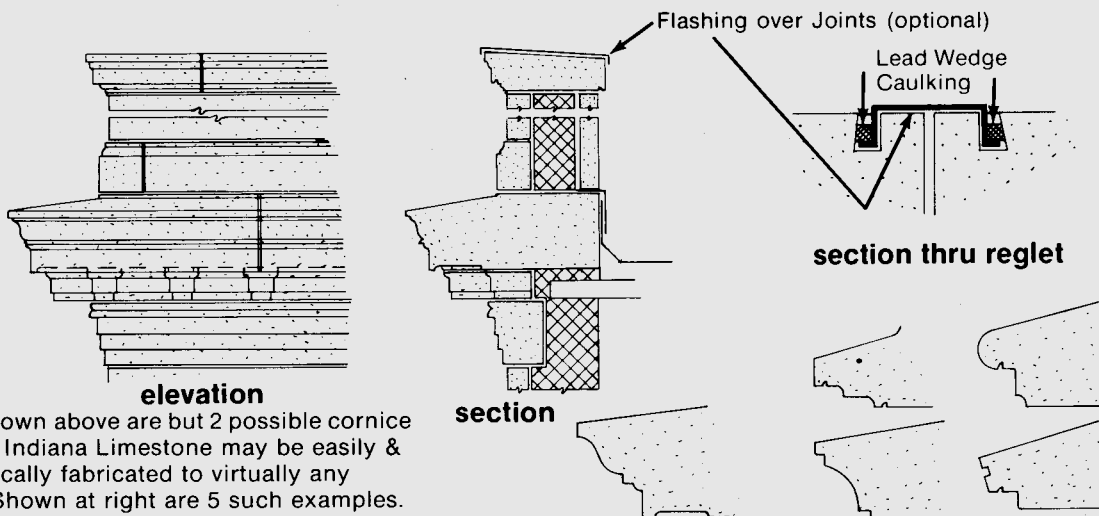

Note: Shown above are but 2 possible cornice designs. Indiana Limestone may be easily & economically fabricated to virtually any profile. Shown at right are 5 such examples.



TYPICAL DETAILS

SOFFITS AND CANOPIES

anchorage to steel

Shown here are 4 basic methods of hanging limestone soffits from a steel frame. Each has its advantages with the main points to consider being:

- The Eisenshank requires 2 lines of bolts at each joint (more steel). Each of the others require a single line of anchors supporting 2 stones.
- Systems 1, 2, and 3 below are preferable for adjusting and aligning of soffit stones using this type of anchor and support. Each stone is aligned individually since it is free from adjoining pieces.

Minimum number of hangers per stone—4. Actual number of hangers required is determined by size & weight of stones. Maximum size of stones is determined by minimum thickness desired and ease of erection.

plan 1

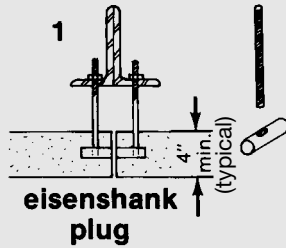
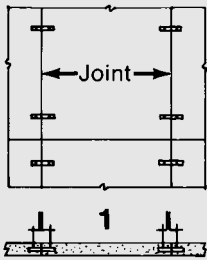

plan 5 & 6

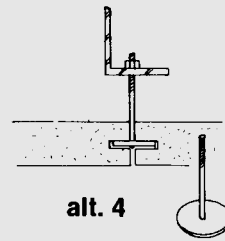
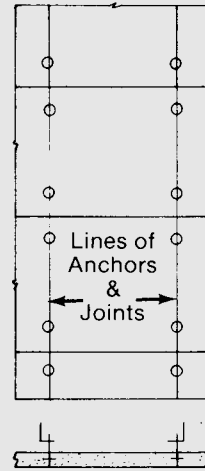
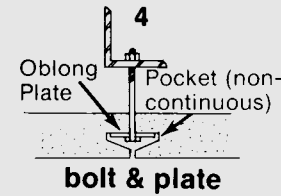

alt. 4 threaded disc anchor

plan 2

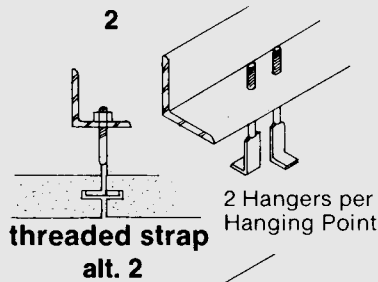
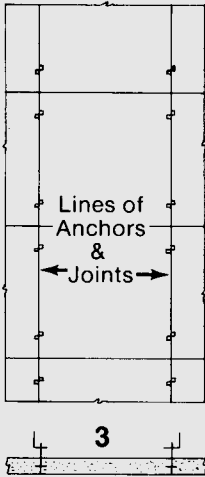

alt. 2 threaded strap

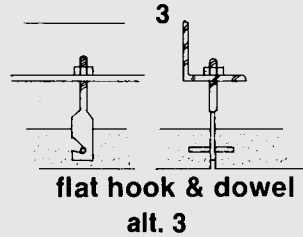

alt. 3 flat hook & dowel

plan 4

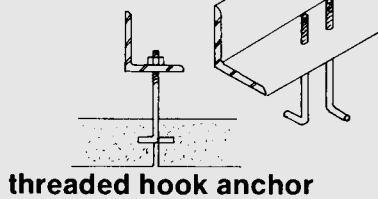
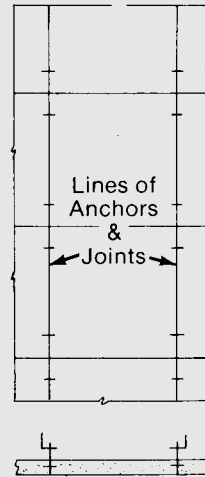

alt. 2 threaded hook anchor

alt. 3 threaded eye bolt & dowel pin

anchorage to concrete

Any of the above methods will work with concrete if Dovetail slots or pockets and sleeves are installed as shown. Also, the under side of the concrete must be water-proofed prior to stone erection.

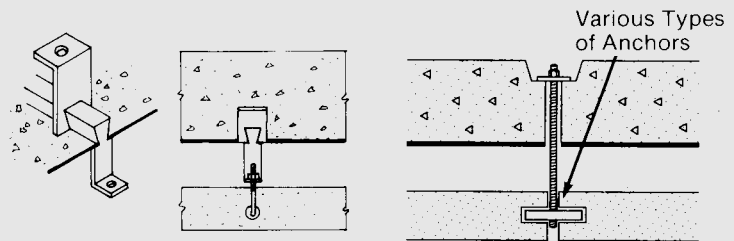

All soffit stones are recommended to be a minimum of 4" thick.



TYPICAL DETAILS

LIMESTONE COPING

Coping can be Fabricated to any size or Profile desired.

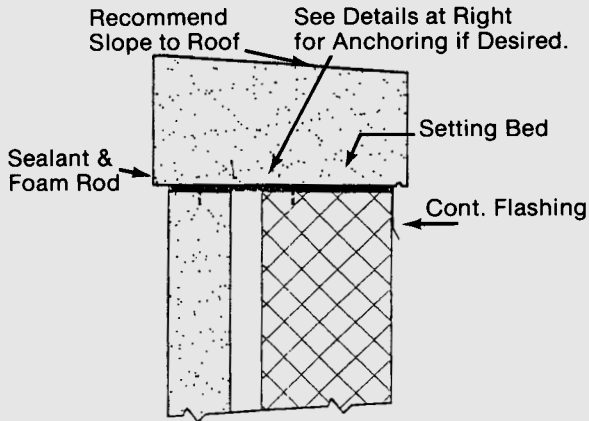

Top block must be grouted to bed anchor properly.

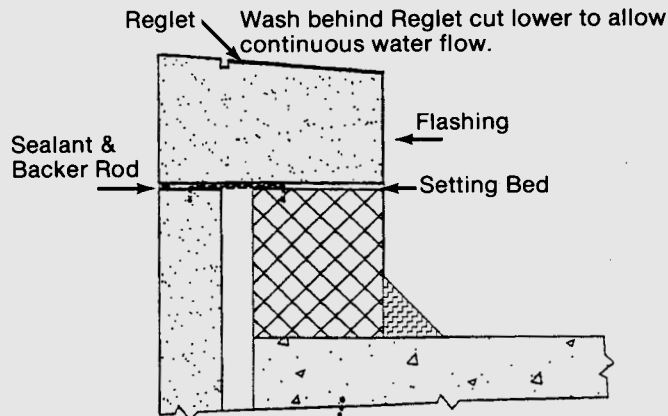

Anchoring

Two suggested methods.

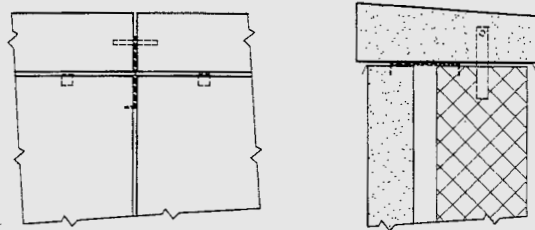

Coping with Cramp Anchor

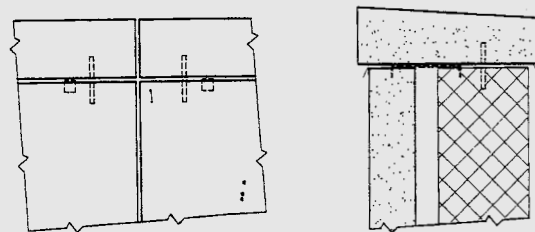

Coping doveled to backup

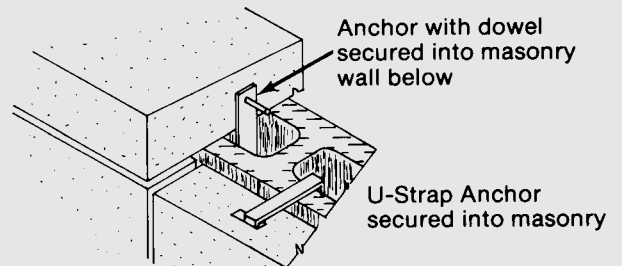

Vertical Joints

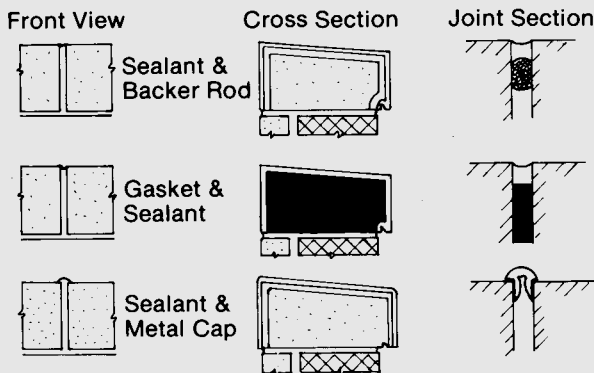

Sealant & Backer Rod, installed properly is preferable to mortar for front, top, & back joints.

Coping, even when installed on planters, screen walls, step cheek walls, and promenade decks should be doveled securely to the wall below. Coping meeting at corners of walls subject to possible expansion should also be doveled to the wall below and the joint between stones should be sealed with a joint sealant and backer rod, making the joint an expansion joint. Very thin copings may require anchors that will resist uplift in high wind load conditions.

flashings

Flashing & vertical joints for stone coping are very important factors in preventing water from getting into the wall and causing extensive damage.

Continuous flashings are recommended but joint sealant and backer rods are also excellent moisture deterrents and also render joints moveable.

PREASSEMBLIES EPOXY-STONE-STEEL

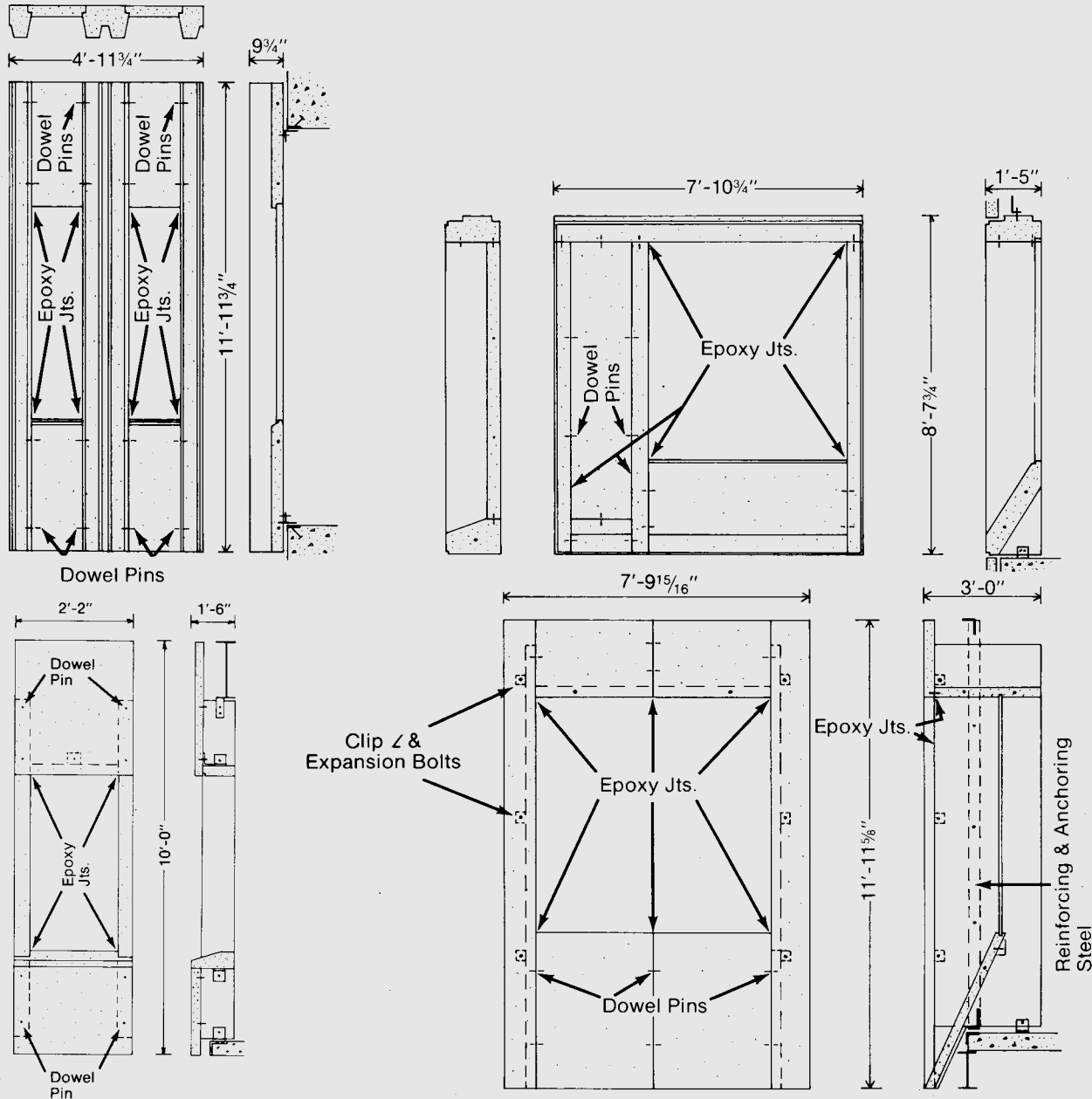

epoxy preassemblies

Shown are four assemblies utilizing high strength adhesives, dowel pins, expansion bolts, and reinforcing steel, when required. All component pieces of limestone are precision cut. Epoxy assembly joints are held to $\pm \frac{1}{8}$ " tolerance when finished for delivery. The assembly appears to be one large sculptured piece of stone with epoxy joints relatively hard to detect.

A combination of textured and smooth finishes can easily be combined into one unit.

Installation of preassembled units into the building structure has eliminated individual piece leveling, plumbing, and aligning. Assemblies reduce installation time.

All stones contained in an assemblage are inter-anchored to each other and the whole assemblage anchored to the structure. Epoxy serves as a joint filler and component unitizer.

Joints between units are sealed with backer rods & elastomeric joint sealants.



PREASSEMBLIES

STONE-STEEL

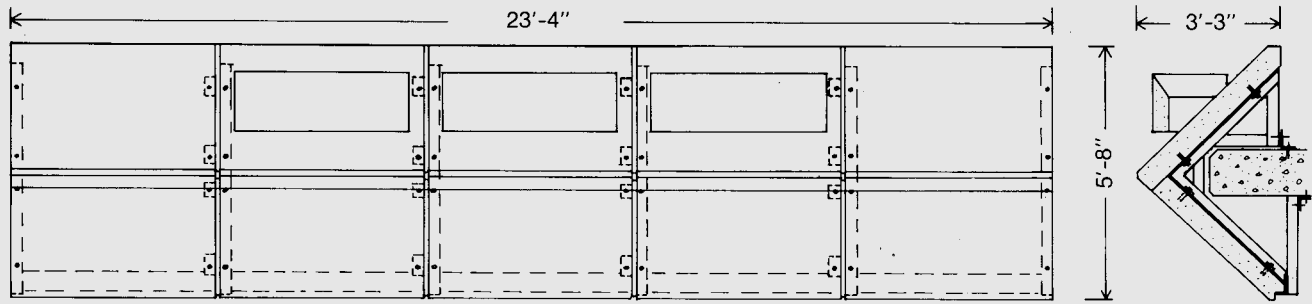

spandrel assemblies

Shown above are two examples of unitizing a multitude of individual spandrel stones with reinforcing and setting steel. Epoxy combines all pieces into one spandrel, and expansion bolts connect the unit to the steel reinforcing and setting steel. The steel framework is leveled and welded to the building structure at the time of installation.

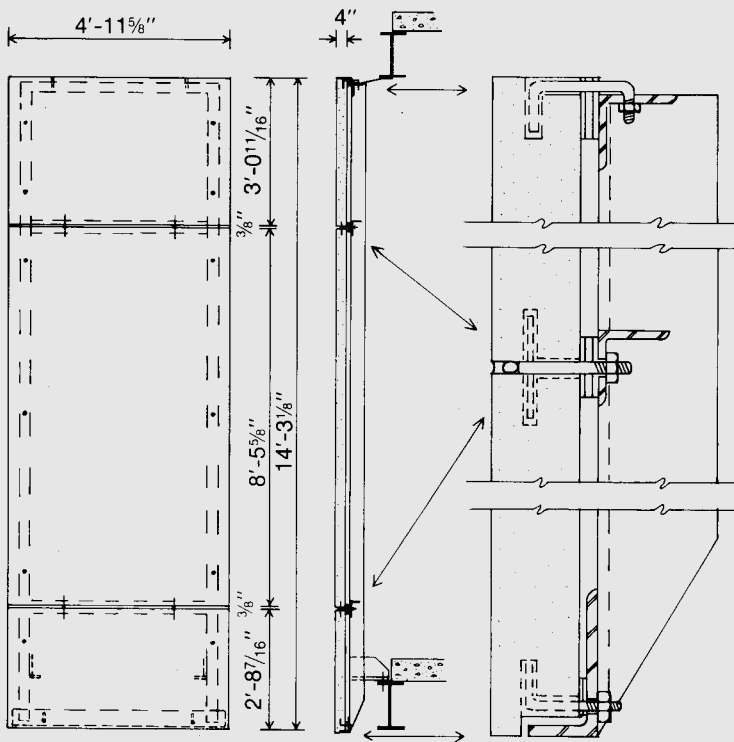
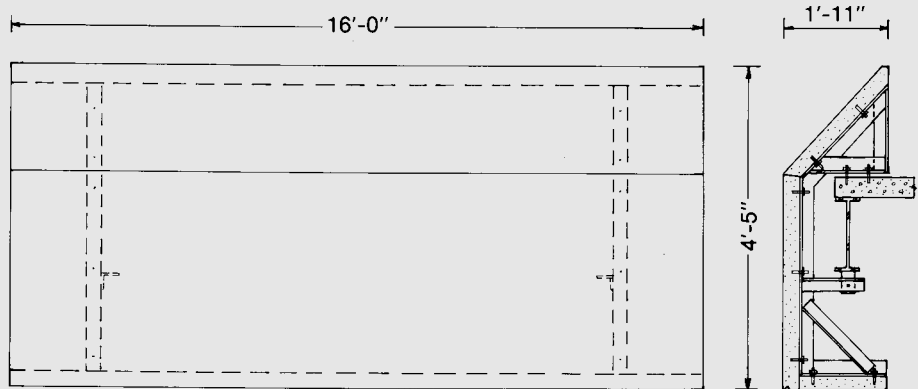

stone and steel frame

Shown at the left is an example of combining two or more pieces of stone panels with a steel frame for accelerated installations. The joints are sealed with elastomeric joint sealants and joint backer. All stone is shimmed and anchored to the steel framework. This type of installation eliminates the need for masonry back-up. By utilizing the strength of the steel it allows reduced thicknesses and sizes of stone panels, thereby reducing weight and cost.

PREASSEMBLIES – COMPOSITE STONE-CONCRETE-STEEL

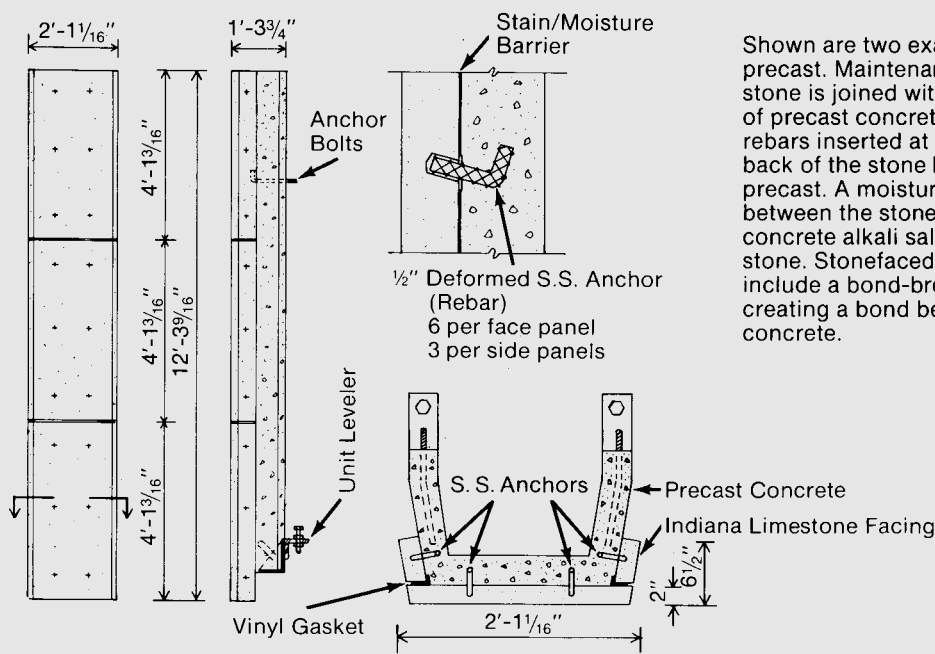
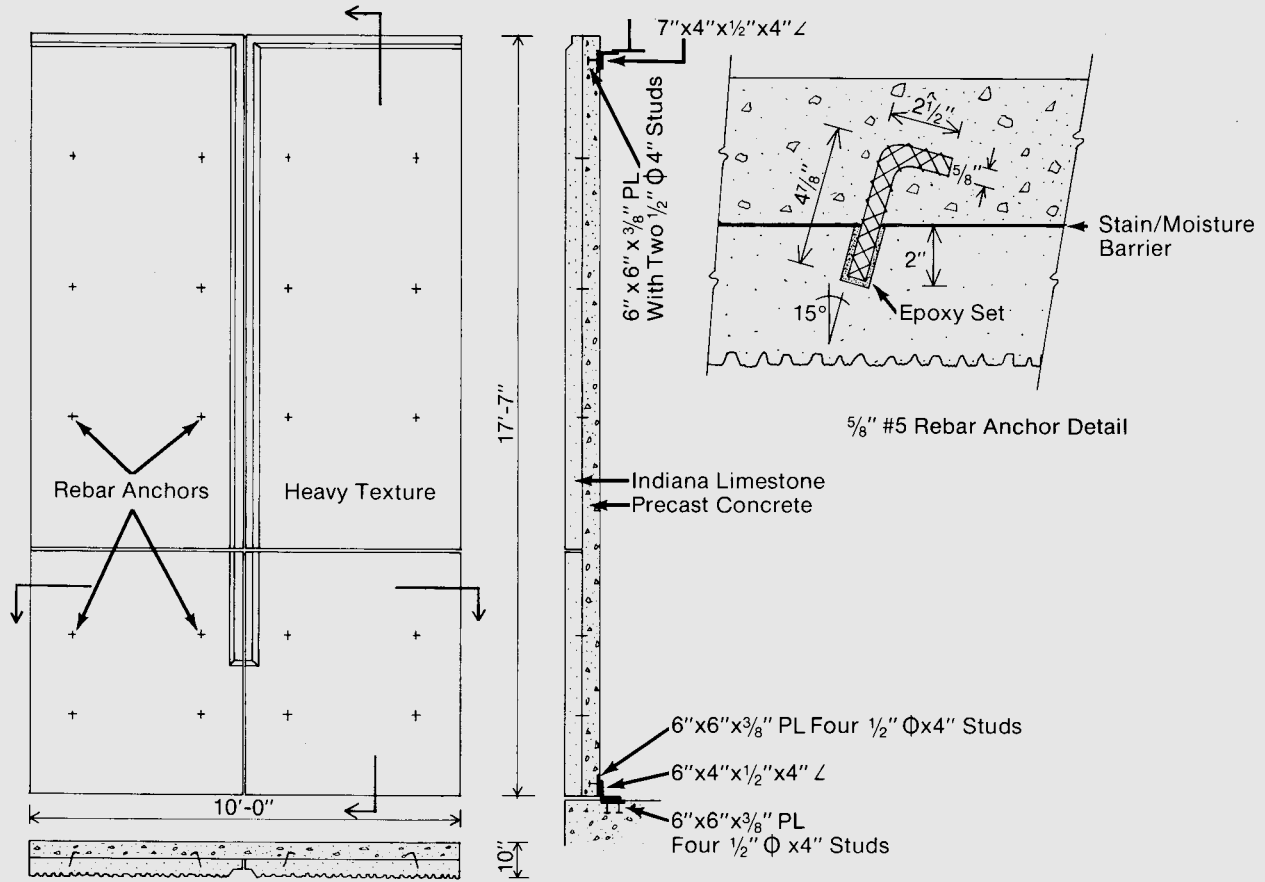

Shown are two examples of limestone faced precast. Maintenance free durability of limestone is joined with the reinforced strength of precast concrete. Stainless steel bent rebars inserted at opposite 15° angles in the back of the stone bond permanently to the precast. A moisture barrier is installed between the stone and concrete to eliminate concrete alkali salts from staining the limestone. Stonefaced precast designs typically include a bond-breaker film as well, to avoid creating a bond between stone and concrete.



CLASSIC ENTABLATURE, COLUMN, AND CAPITAL DETAILS

GREEK IONIC STYLE

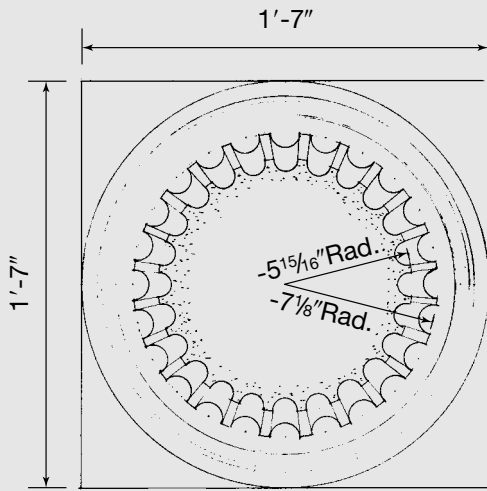

Detail of Fluting

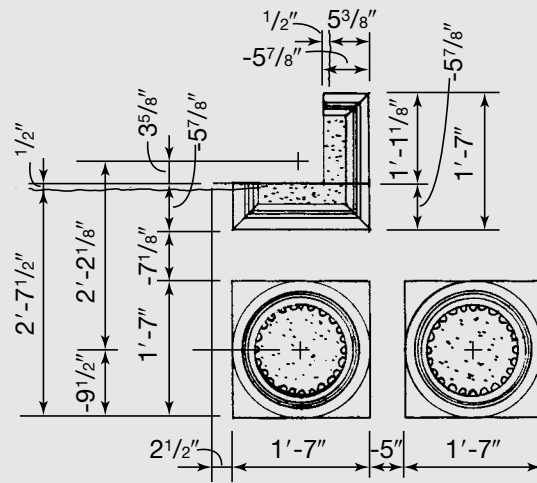

Plan thru Columns

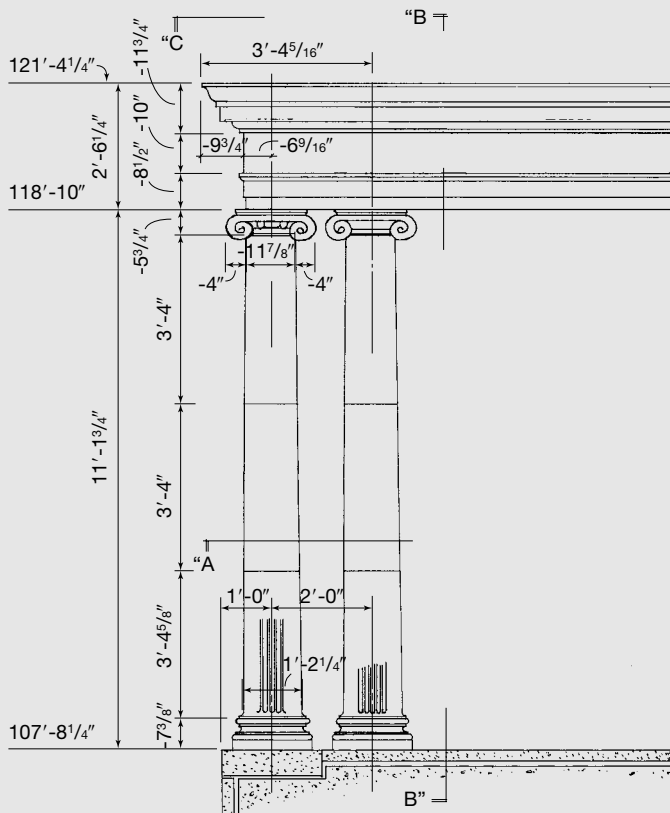

Elevation of Columns

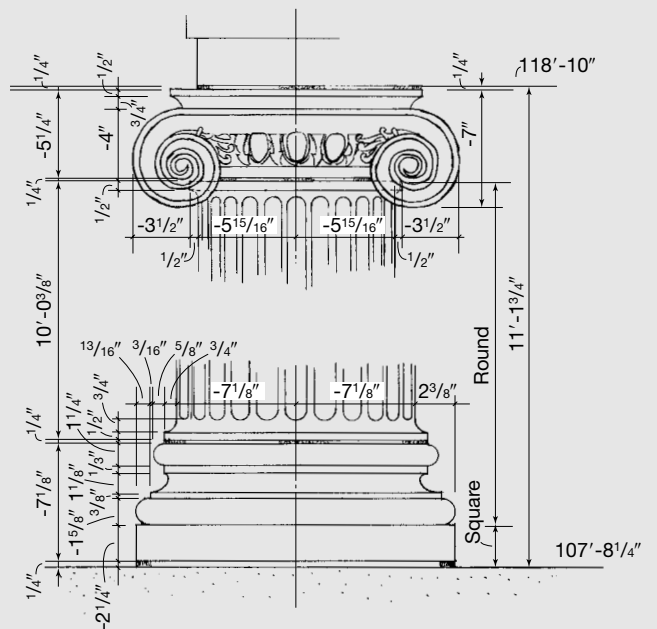

Elevation Details

CLASSICAL ENTABLATURE, COLUMN, AND CAPITAL ENTABLATURE, COLUMN, AND BASE SECTIONS GREEK IONIC STYLE

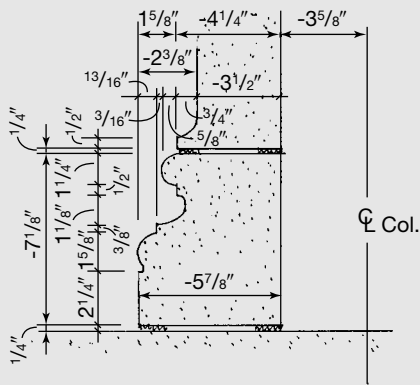

Typical Jointing between Shaft and Base

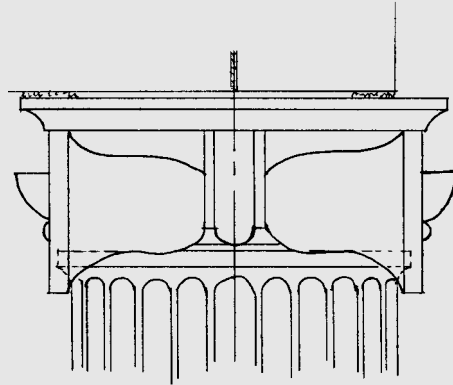

Side View of Cap

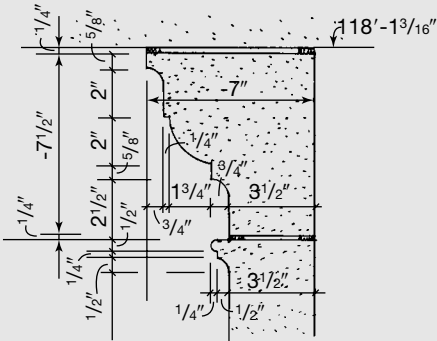

Typical Jointing between Shaft and Cap

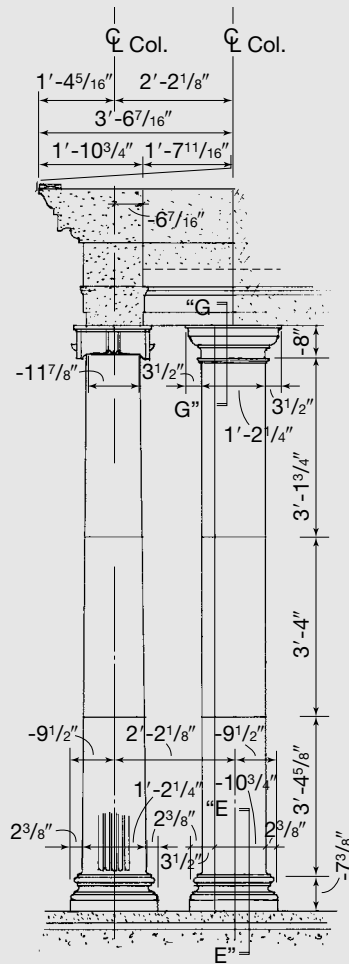

Section thru Columns

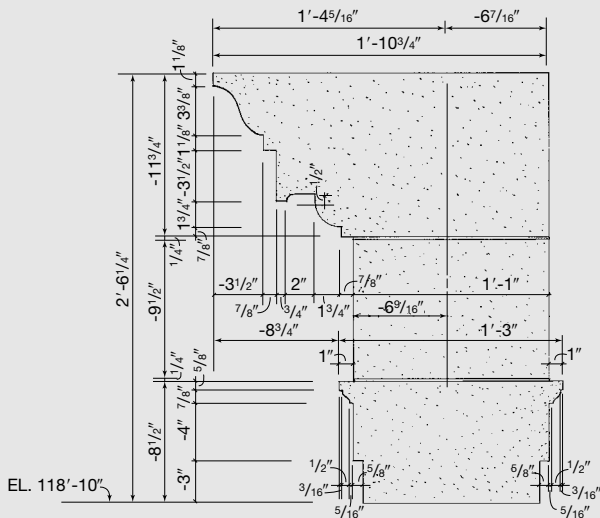

Cornice Detail above Cap



COLUMNS-CAPITALS-ENTABLATURES PROPORTIONS

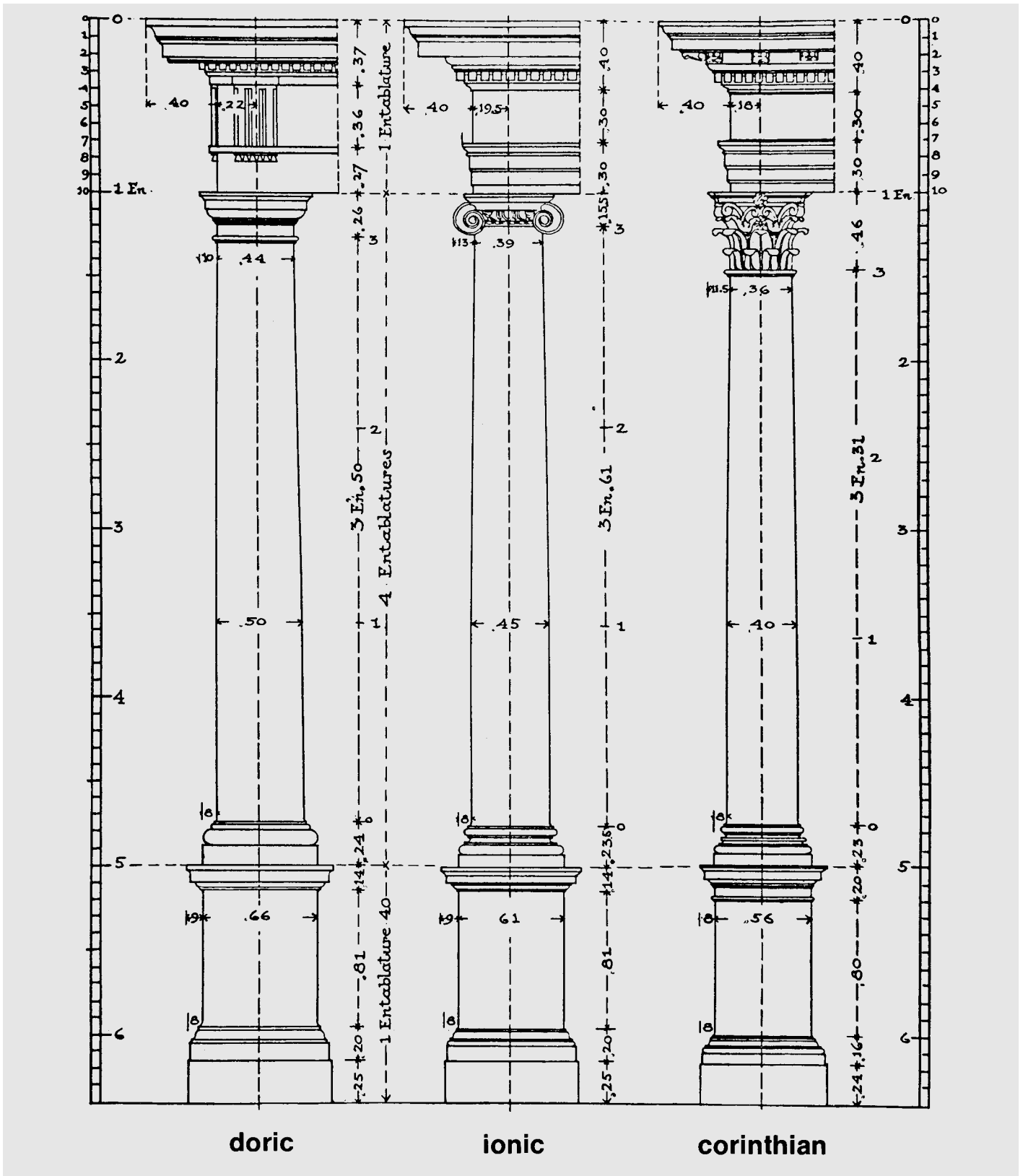

Column drum beds, and the beds of column bases and capitals, should be matched to their membering surfaces in the mill prior to shipment. The stone fabricator has the responsibility to produce column parts to the tolerance allowed for other "critical depth" situations.

GABLED PORTICO

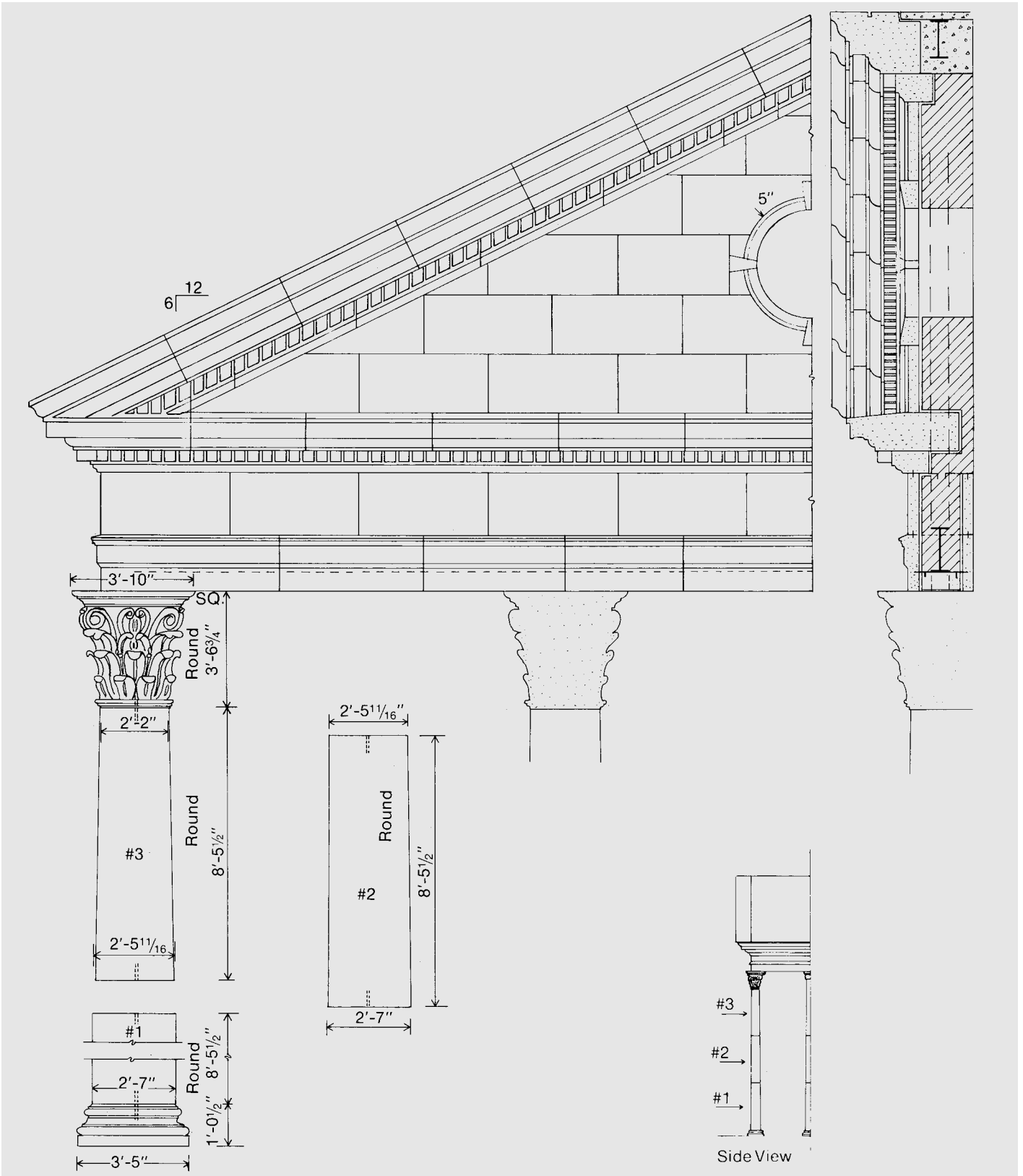

Column drum beds, and the beds of column bases and capitals, should be matched to their membering surfaces in the mill prior to shipment. The stone fabricator has the responsibility to produce column parts to the tolerance allowed for other "critical depth" situations.

BALUSTRADE AND BALUSTERS

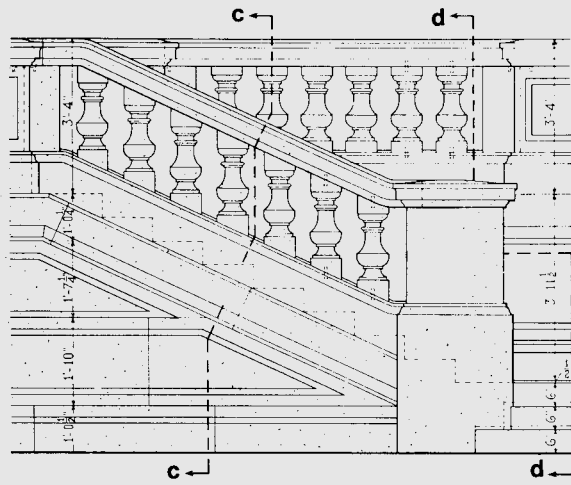

elevation

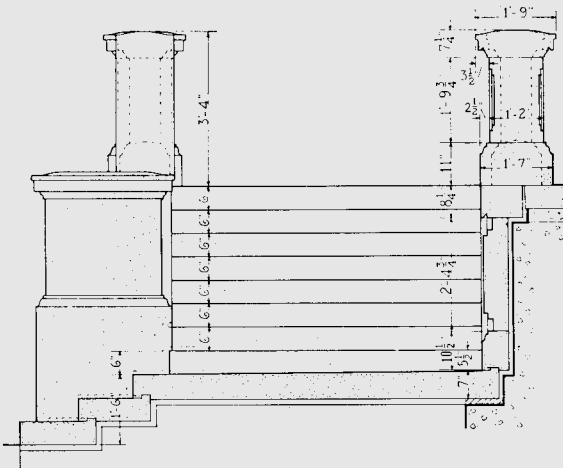

section a-a

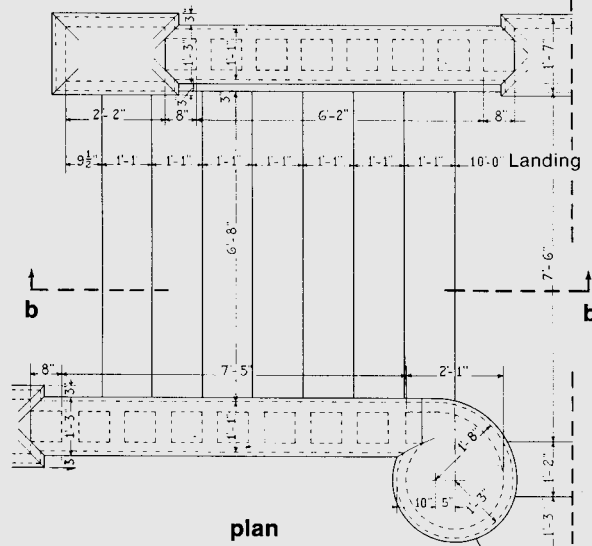

plan

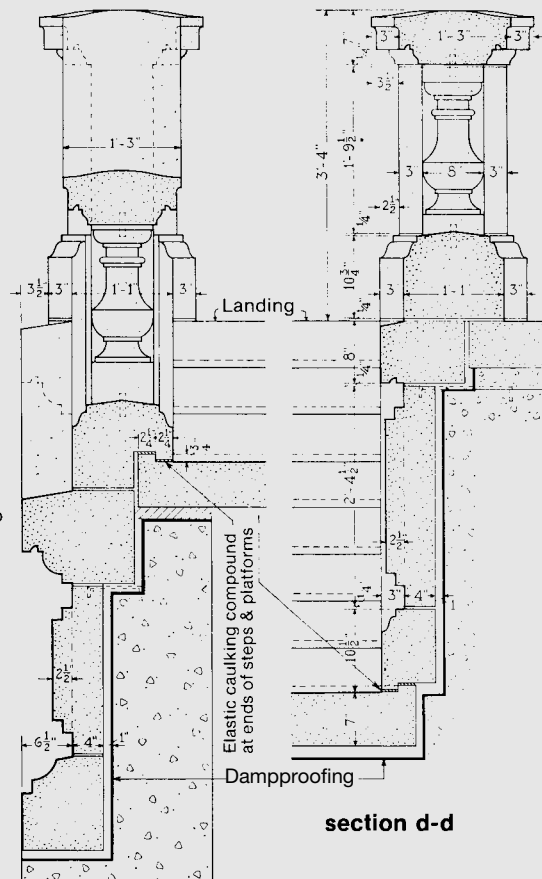

section c-c

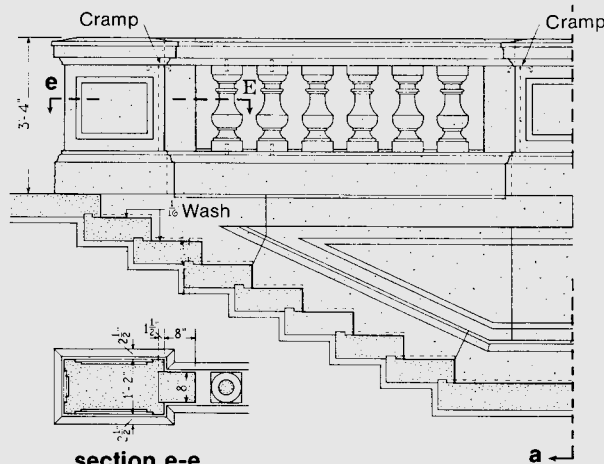

section e-e

section b-b

Elastic caulking compound
at ends of steps & platforms

Dampproofing

section d-d

ROSE WINDOW

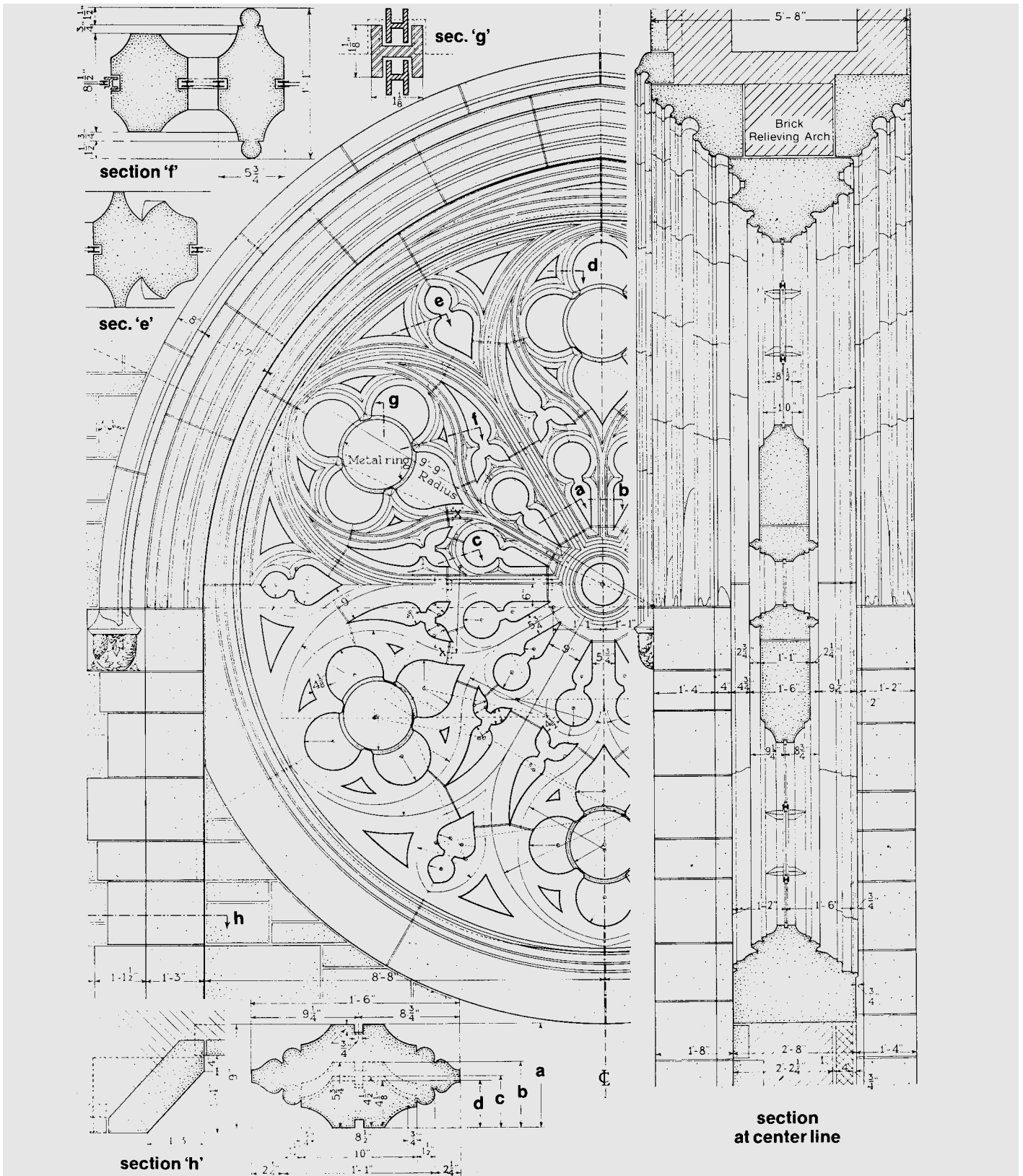

ashlar veneer and trim

The versatility of Indiana Limestone ashlar veneer suggests its consideration for almost any type of building or style of architecture. Whether used in the popular split face finish or one of the sawed finishes, ashlar veneer is one of the most attractive forms of Indiana Limestone and is also one of the least expensive. It shares the qualities common to all Indiana Limestone: rugged or tailored good looks, depending on design requirements; excellent weather face; dependable performance.

Produced as a standard product and furnished in random lengths to be cut as required at the jobsite, Indiana Limestone ashlar veneer is broadly available from a network of dealers over the country, most of whom also stock standard trim items which can be cut to length with ordinary jobsite masonry saws or hand tools. Window and door sills, coping and trim courses are produced in standard heights and thicknesses and require

no additional work other than cutting to proper length on the job. Ashlar veneer and its matching trim are set in mortar like any unit masonry product, and may be applied to any type of backup as illustrated in the two following pages. With ashlar veneer, no shop drawings or anchors are included, and the stone is priced per ton.

With no change in material specification or cost, Indiana Limestone ashlar veneer can emphasize contemporary lines, or complement a rustic, woody setting. It is widely used in the construction of smaller office buildings, shopping centers, apartments and condominiums as well as single-unit homes.

When limestone is used as trim, particularly as belt or string courses in nominal 4" thickness and less than 1'0" high, galvanized or stainless brick anchors penetrating the joint material only may be used and may be located in the top bed only. In course heights 1'0" high, but less than 1'6", standard stainless steel bent stone anchors should be used, and as a general rule, these may be located in the top beds of the stone only. In course heights 1'6" and over, conventional stainless steel bent stone anchors should be used in the top and bottom beds of the stone.

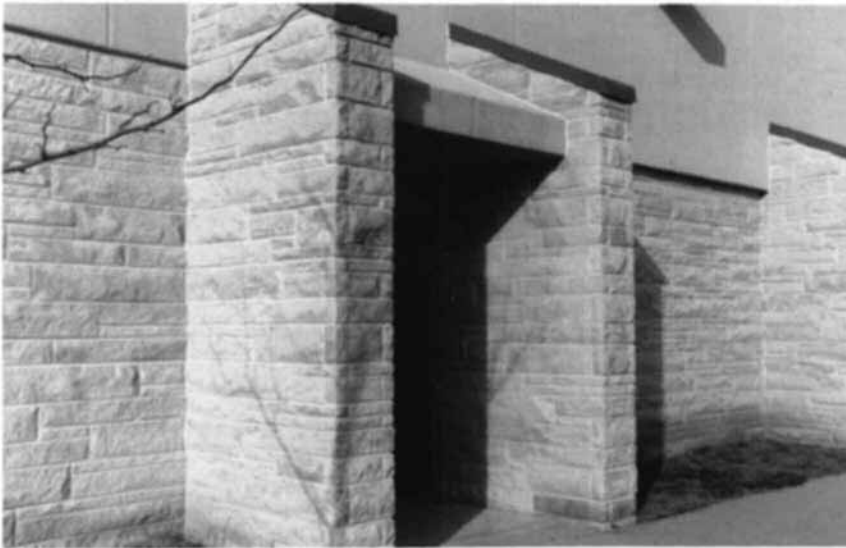



ASHLAR STONE VENEER STANDARD WALL PATTERNS

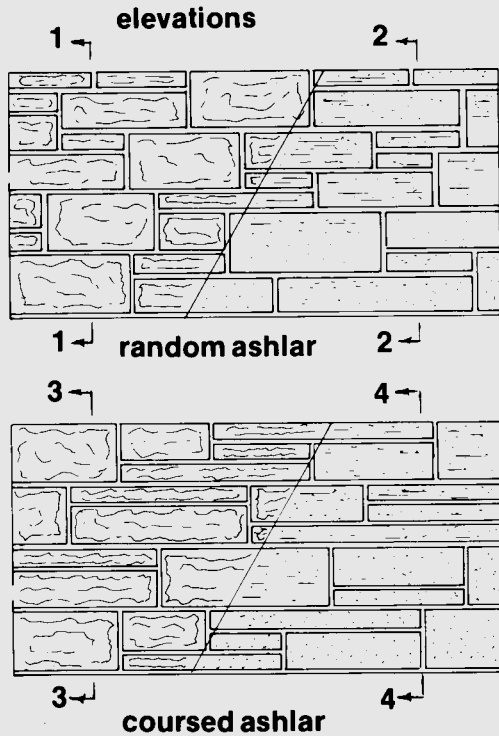

Random ashlar and coursed ashlar are both made from strips of limestone with lengths cut as desired at the jobsite. The only real difference between them is that the mason lays to a line with one (coursed) and does not with the other (random).

Standard course heights are 2 1/4", 5", 7 3/4", (and sometimes 10 1/2" and 13 1/4") based upon 1/2" beds and joints.

The most common and economical finish for this stone is split face. However, other standard industry sawed finishes are also available.

Either pattern may be varied further by the use of more than one thickness as shown in Section at right, thereby creating a three dimensional effect (staccato pattern).

Split face strip ashlar may have either sawed or split backs. Sawed backs allow a close tolerance in setting. Split backs allow the mason to select a face for greater boldness.

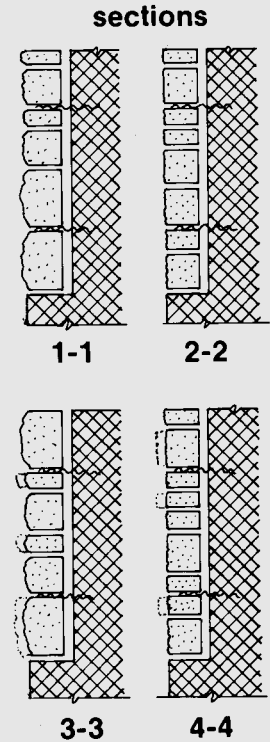

WEBWALL AND DRYWALL

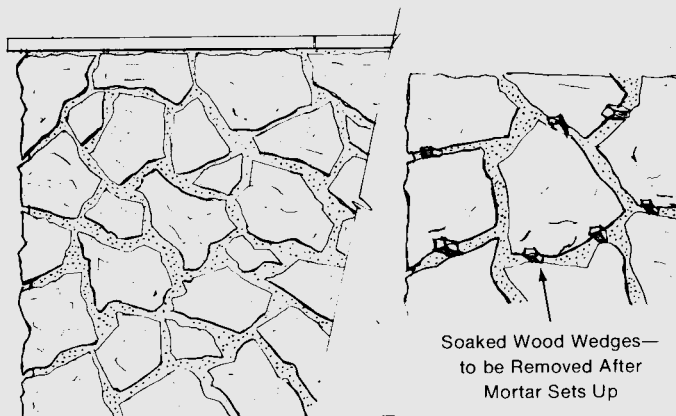

Soaked Wood Wedges—
to be Removed After
Mortar Sets Up

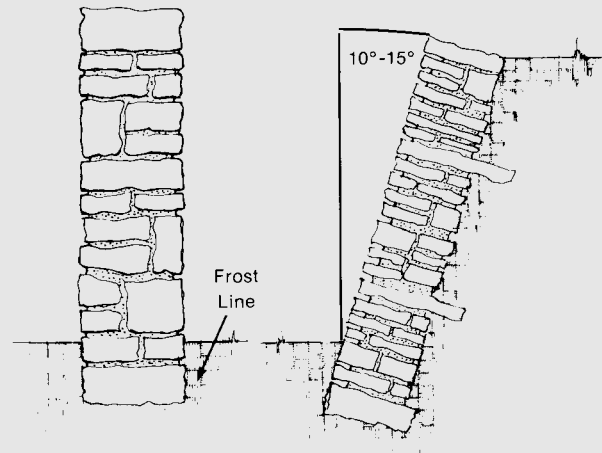

Webwall patterns are attractive and easy to set. The web-wall style is a veneer and must be set against a firm backup and on a solid foundation or ledge. Shaping stones with mallet or chisel can create smaller joints. Wedges may be used occasionally to hold stones in place until mortar sets. Sawed wall coping is particularly effective used with these freeform patterns.

Grade control with simple, inexpensive retaining walls is both practical and attractive. Dry-set, properly sloped walls form natural terraces and provide planting areas for flowers and ivy.

ASHLAR STONE VENEER

RANDOM ASHLAR ANCHORAGE

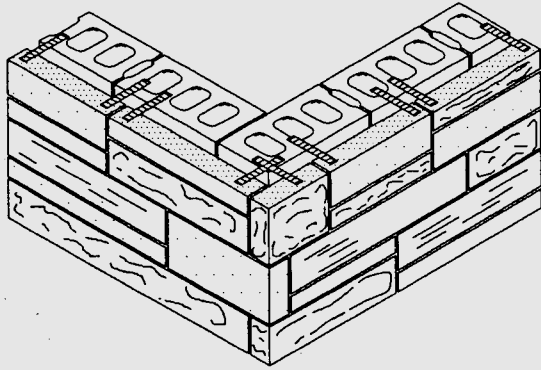

Stone Veneer with Bond Stones Anchored to Concrete Block Backing.

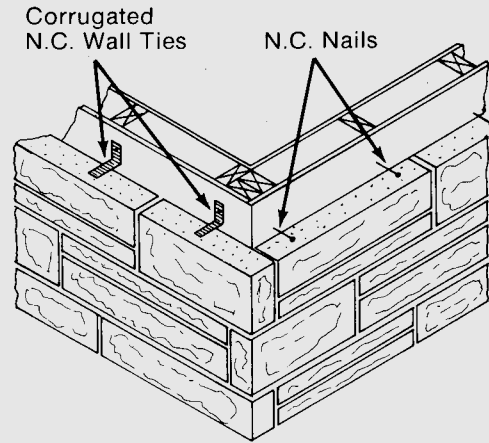

Stone Veneer Anchored to Wood Frame Backing

TRIM—WINDOW SILLS, COPING & WALL CAPS

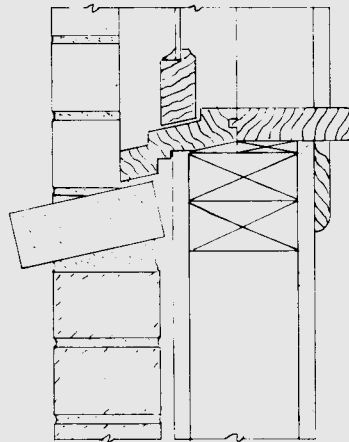
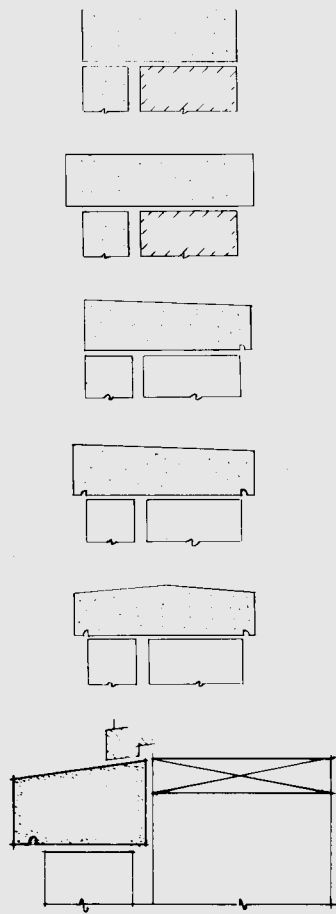

Flat sawed-stone sills may be tipped for wash surface, or set flat in windows or as capping for wing-wall extensions. This is particularly effective when used as band course at sill level. Dealer or his supplier can provide specially sawed shapes where checked-out areas are needed.

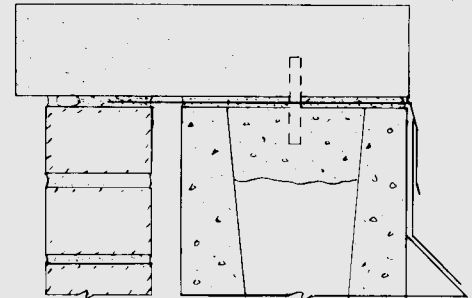

Parapet Coping

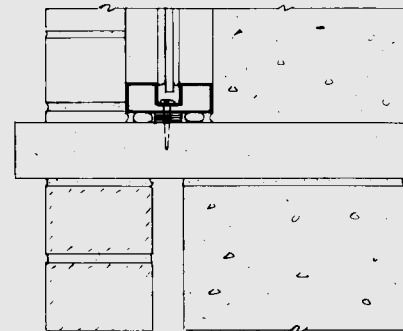

"Through-the-Wall" Sill for Fixed Window

Additional information on this subject is contained in ILI's publication "The Finishing Touch."



TYPICAL DETAILS

QUOINS, WATERTABLES AND BASE COURSES

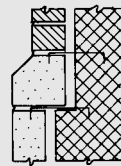
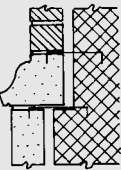
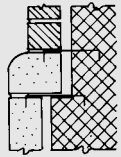
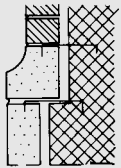

a 1

Typical
Watertables

Note: See shaded box, page 33, under Flashing and Metalwork.

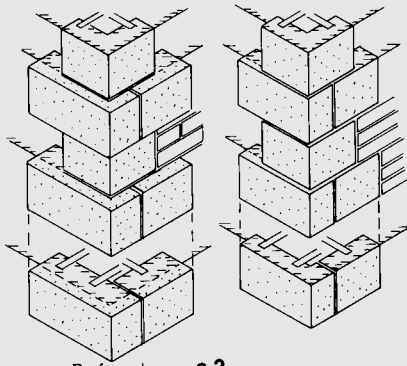

Preferred **c 2**
Typical Quoin Details

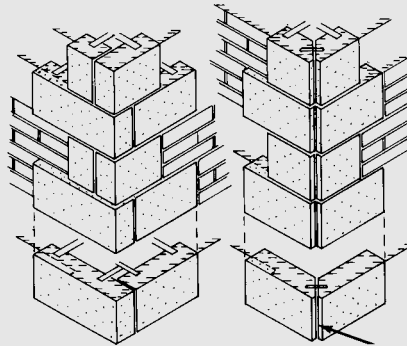

Quirk Miter

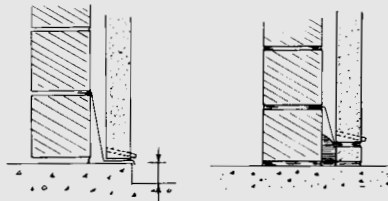

Note: Isolate stone from grade moisture with a concrete ledge or a dampproofed starter course with flashing as shown.

If this undergrade condition cannot be avoided, stone below earth or concrete grade **MUST** be protected by dampproofing. See comments pp. 13, 30, 31 & 32.

NOTE: Never cover unprotected stone with dirt. Protect stone from mud being splashed upon it during construction.

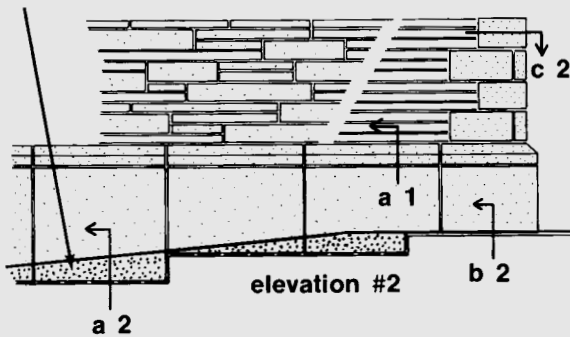

elevation #2

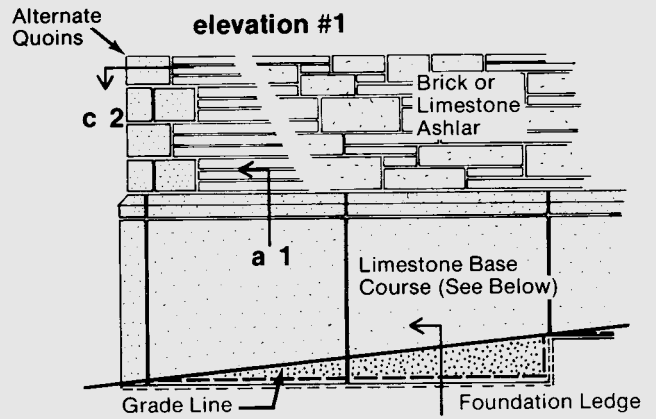

elevation #1

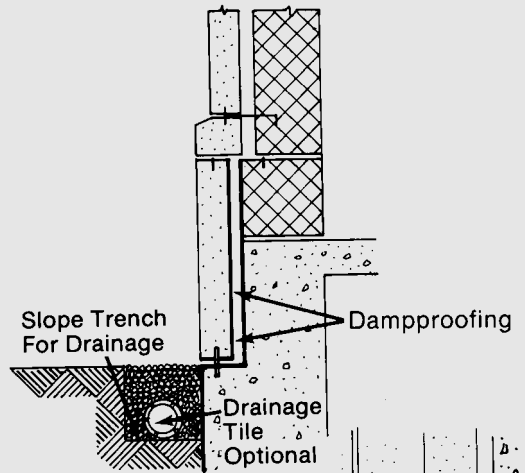

section b 2

Grade Line at Foundation Line

See Section b-2
for continuation

Weep Holes

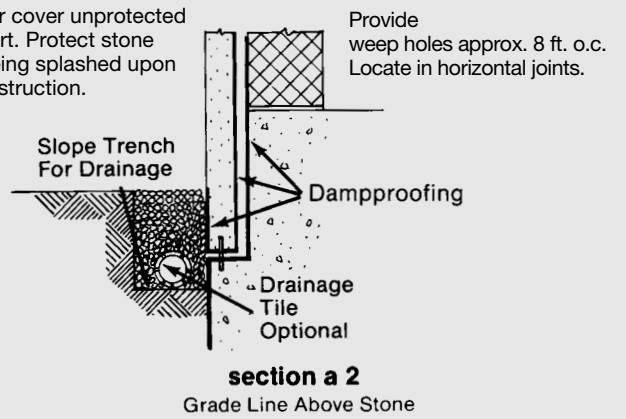

section a 2

Grade Line Above Stone

SECTION IV

case histories

Invitation	85
A PORTFOLIO OF LIMESTONE PROJECTS	86-113
Textured Panels	114
Sun Screen	115
Limestone Fountain	116
Historic Restoration	117
Post Tensioned Spandrels	118
Continuous Kerf—Aluminum Support System	119
Limestone on Precast	120
Steel Girt System	121
Preassembled Units	122
Plant-installed Support Frames	123
Vertical and Horizontal Plane Changes	124

an invitation from the committee on case histories

The Case History Section of the *Indiana Limestone Handbook* is continually updated. Each reprinting of the *Handbook* (every two years, on the average) sees new Histories being added.

Buildings considered for use in the section need not be totally of Indiana Limestone. Beauty and architectural excellence, interesting or unique construction methodology, unusual or unusually good treatment of stone areas, the use of stone to solve difficult design problems: all these factors are weighed in the selection of Case History projects.

Architects, general contractors and owners who feel that a building with which they have been associated or which is presently under construction or contemplated fits one of these categories are invited to send photos and architectural drawings to the Institute. The Handbook Committee responsible for the Case History section will review such material promptly, and will insure its ultimate safe return.

Case Histories include descriptive material considered pertinent to the specific area of interest, and the Case History Committee will arrange for detail drawings and elevations where required. Good final or progress photographs are a part of each History.

Projects chosen for inclusion in the Case History section are tastefully credited both on the inside front cover of the *Handbook* and on the Case History page itself.

Interested persons should write to Case History Committee, in care of the Institute, and include descriptive material, drawings and photographs with their first communication.

This is an ongoing effort, and buildings submitted for consideration will be kept in an active file until a final decision is made, after which time additional material may be requested by the Committee; unneeded material will be returned.

A Portfolio
of
Projects
in
Indiana
Limestone



Indiana State Museum

Indianapolis, Indiana

Ratio Architects, Inc.
Indianapolis, IN



Photos: © 2002 Jeff Goldberg/Esto. All rights reserved.

Simmons-Gill House

Chicago, Illinois

Bauhs & Dring Architects and Planners
Chicago, Illinois

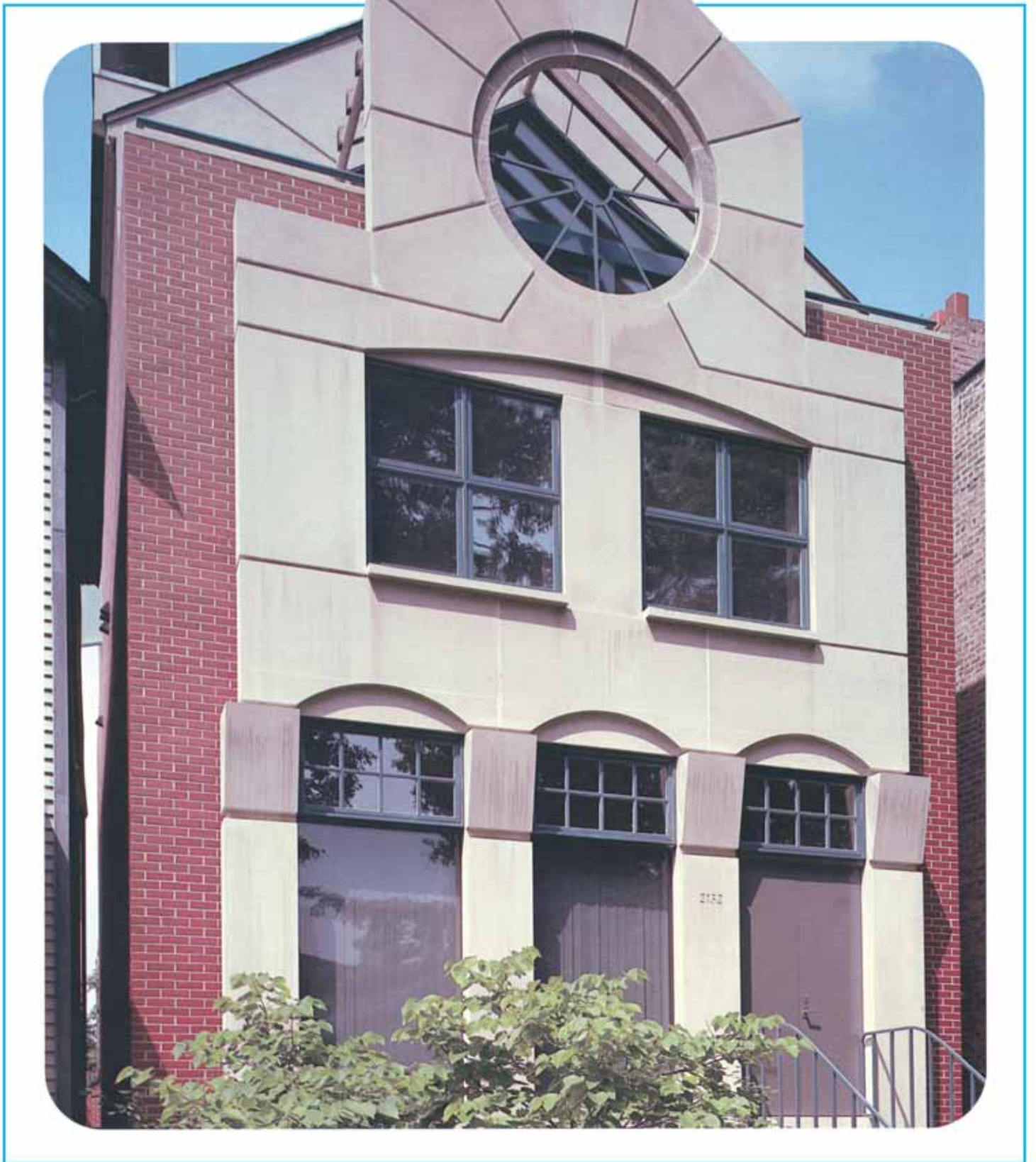

Muhlenberg Library

Allentown, Pennsylvania

Geddes Brecher Qualls Cunningham Architects
Philadelphia, PA



1999 Broadway Denver

Denver, Colorado

C. W. Fentress and Assoc., P.C.
Denver, CO



The Crescent

Dallas, Texas

John Burgee Architects with Philip Johnson
New York, NY

Shepherd & Partners
Dallas, Texas



The United States Holocaust Memorial Museum

Washington, DC

James Ingo Freed of Pei Cobb Freed & Partners
New York, NY

Notter, Finegold & Alexander, Inc., Associate Architects
Boston, MA



Procter and Gamble Headquarters

Cincinnati, Ohio

Kohn Pedersen Fox Associates, P.C.
New York, NY



Software Engineering Institute Carnegie Mellon University

Pittsburgh, Pennsylvania

Bohlin-Powell-Larkin-Cywinski Architects
Philadelphia, PA
Burt Hill Kosar Rittelmann Associates
Butler, PA



Virginia Museum of Fine Arts

Richmond, Virginia

Hardy Holzman Pfeiffer Associates
Washington, DC



The Ronald Reagan Building and International Trade Center

Washington, DC

Pei Cobb Freed & Partners
New York, NY



Seattle Art Museum

Seattle, Washington

Venturi Scott Brown and Associates
Philadelphia, PA

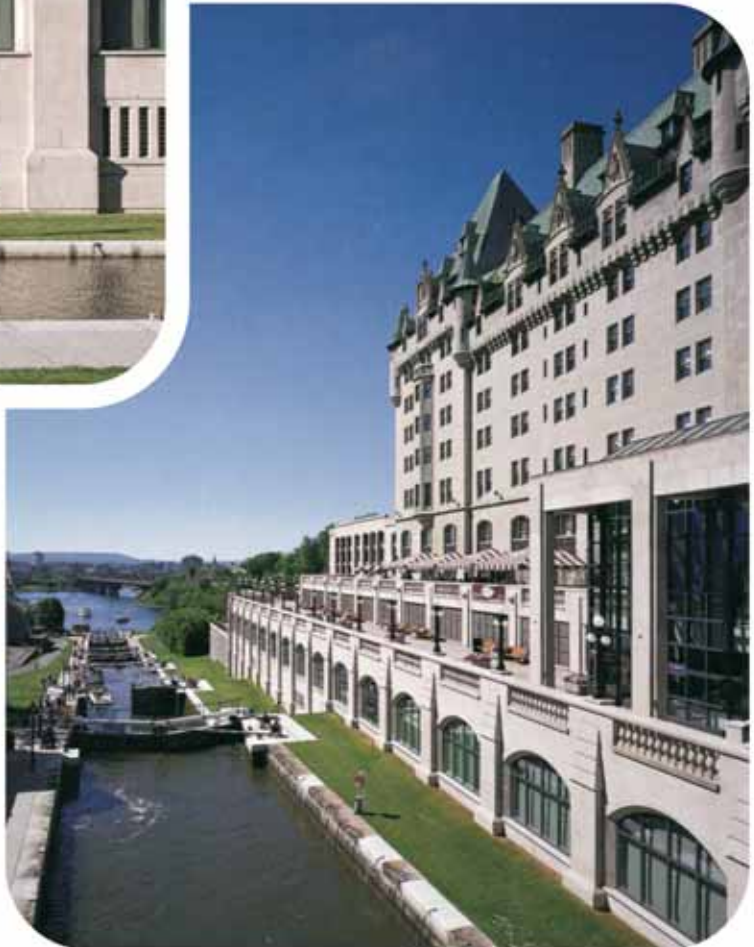

Photo: Matt Wargo for VSBA

Chateau Laurier Terrace Rehabilitation/ Canadian Museum of Contemporary Photography

Ottawa, Ontario, Canada

Rysavy & Rysavy, Architects
Sioux Falls, SD



Commonwealth-Edison Company Switching Station

Chicago, Illinois

Tigerman, Fugman, and McCurry, Architects
Chicago, IL

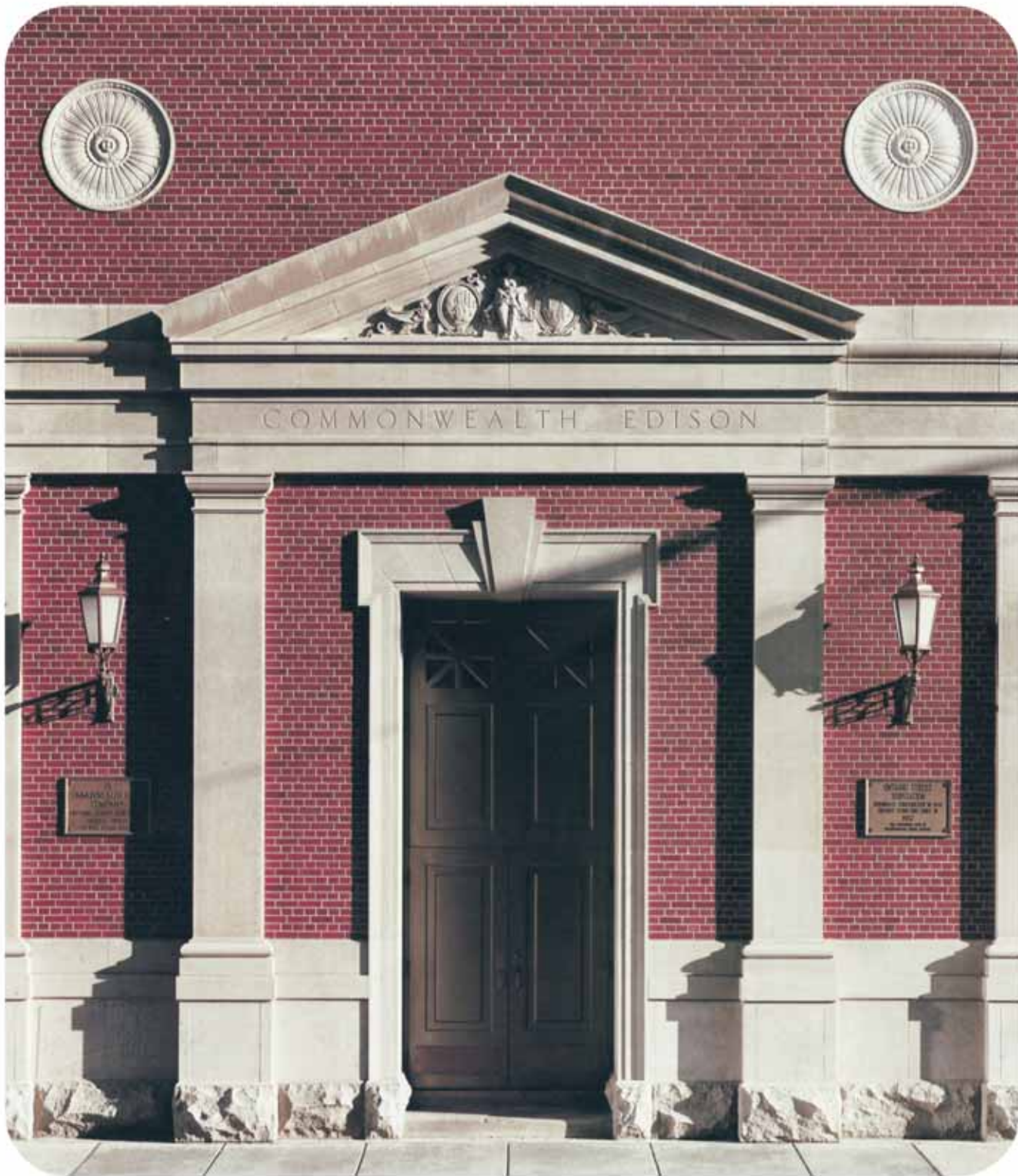

Market Square

Washington, DC

Morris Architects
Houston, TX
Hartman-Cox Architects
Washington, DC



Emmis Communications World Headquarters

Indianapolis, Indiana

Ratio Architects, Inc.
Indianapolis, IN

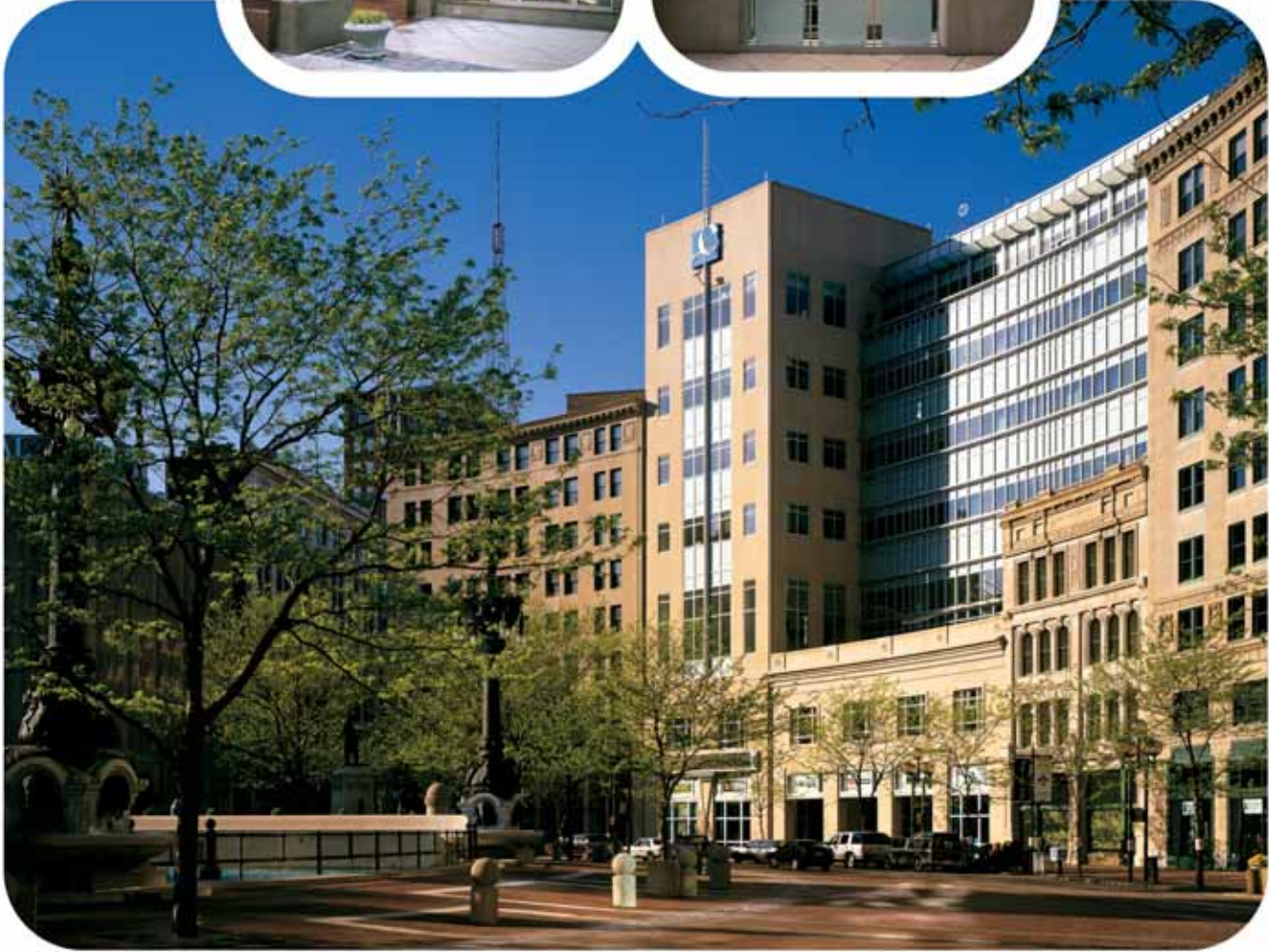

Photography: Jon Miller, Hedrich Blessing

The Robert & Judi Newman Center for the Performing Arts

University of Denver
Denver, Colorado

G. Cabell Childress, FAIA University of Denver Architect Emeritus
Mark E. Rodgers, AIA University of Denver Architect

Anderson Mason Dale Architects
Denver, Colorado



Central Safety Building

Columbus, Ohio

Brubaker/Brandt, Inc.; Moody/Nolan, Ltd., Architects
Columbus, OH



Indiana State Office Building

Indianapolis, Indiana

Howard Needles Tammen & Bergendorf, Architects
Indianapolis, IN



Alabama Judicial Center

Montgomery, Alabama

Barganier, McKee & Sims, Architects
Montgomery, AL



Union Planters National Bank Headquarters Building

Memphis, Tennessee

Hnedak Bobo Group, P.C., Architects
Memphis, TN



Gazebo

Muncie, Indiana

Millennium Park

Chicago, Illinois

OWP&P Architects
Chicago, IL

Cary Schafer Designs
Fort Wayne, IN

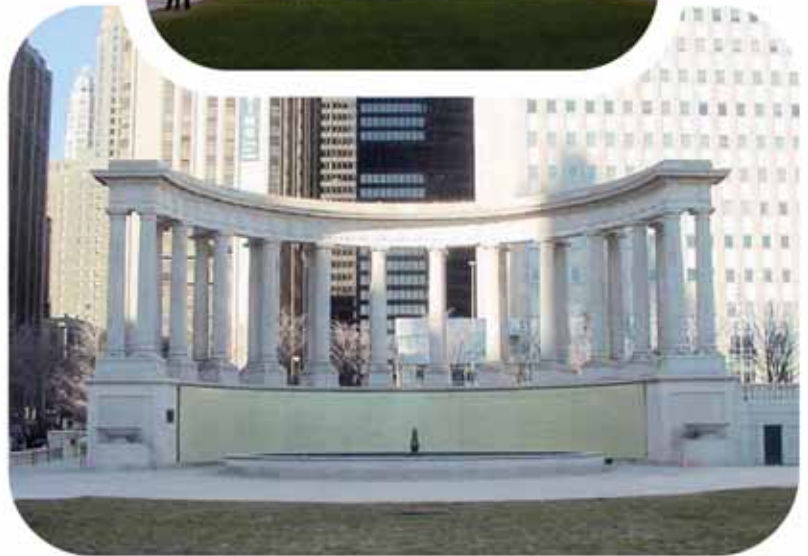

Photos: Bob Harr, Hedrich-Blessing



Photos: Cary Schafer

Weinstein Hall
University of Richmond
Richmond, Virginia

SMBW Architects
Richmond, VA



Constitution Center

Philadelphia, Pennsylvania

Pei Cobb Freed and Partners
New York, NY



Duke University Divinity School

Durham, North Carolina

Hartman-Cox Architects
Washington, DC



Photos: Bryan Becker Photography

Indiana Historical Society

Indianapolis, Indiana

CSO Schenkel Shultz Architects
Indianapolis, IN



Christian Brothers College High School

Town & Country, Missouri

Mackey Mitchell Associates Architects
St. Louis, MO



Paul Barret Jr. Library, Rhodes college

Memphis, Tennessee

Architects: Hanbury Evans Wright Viattas & Company, Norfolk, VA
Shepley Bullfinch, Boston, MA



Photos: Stephen Rintoul

CASE HISTORY

TEXTURED PANELS



Willowbrook Park Office Bldg. # 6
Indianapolis, Ind.
Architect: Cooler, Schubert & Assoc., Inc.

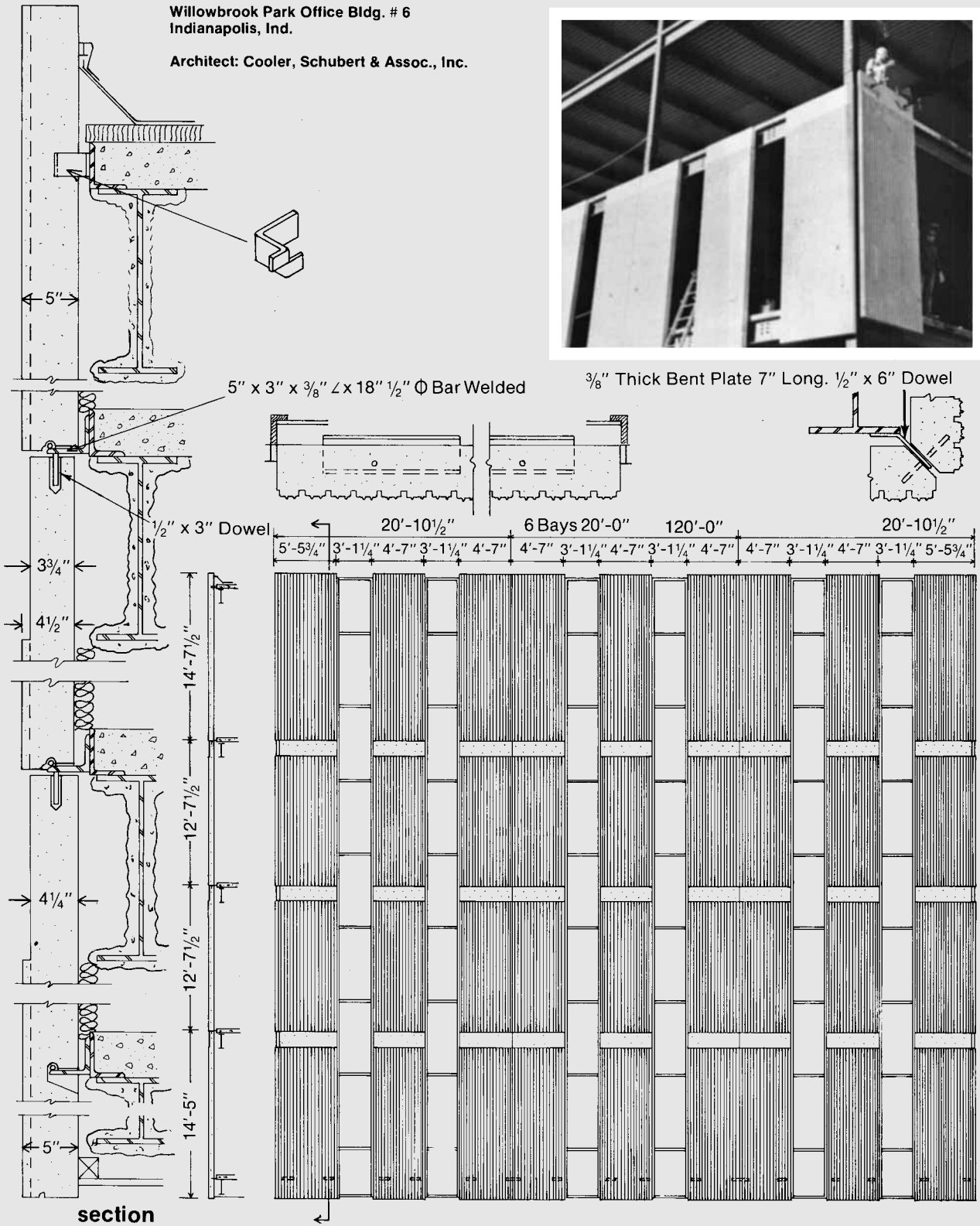



CASE HISTORY

SUN SCREEN



Main Library Addition
The Ohio State University, Columbus, Ohio
Architects: Lorenz, Williams, Lively & Likens

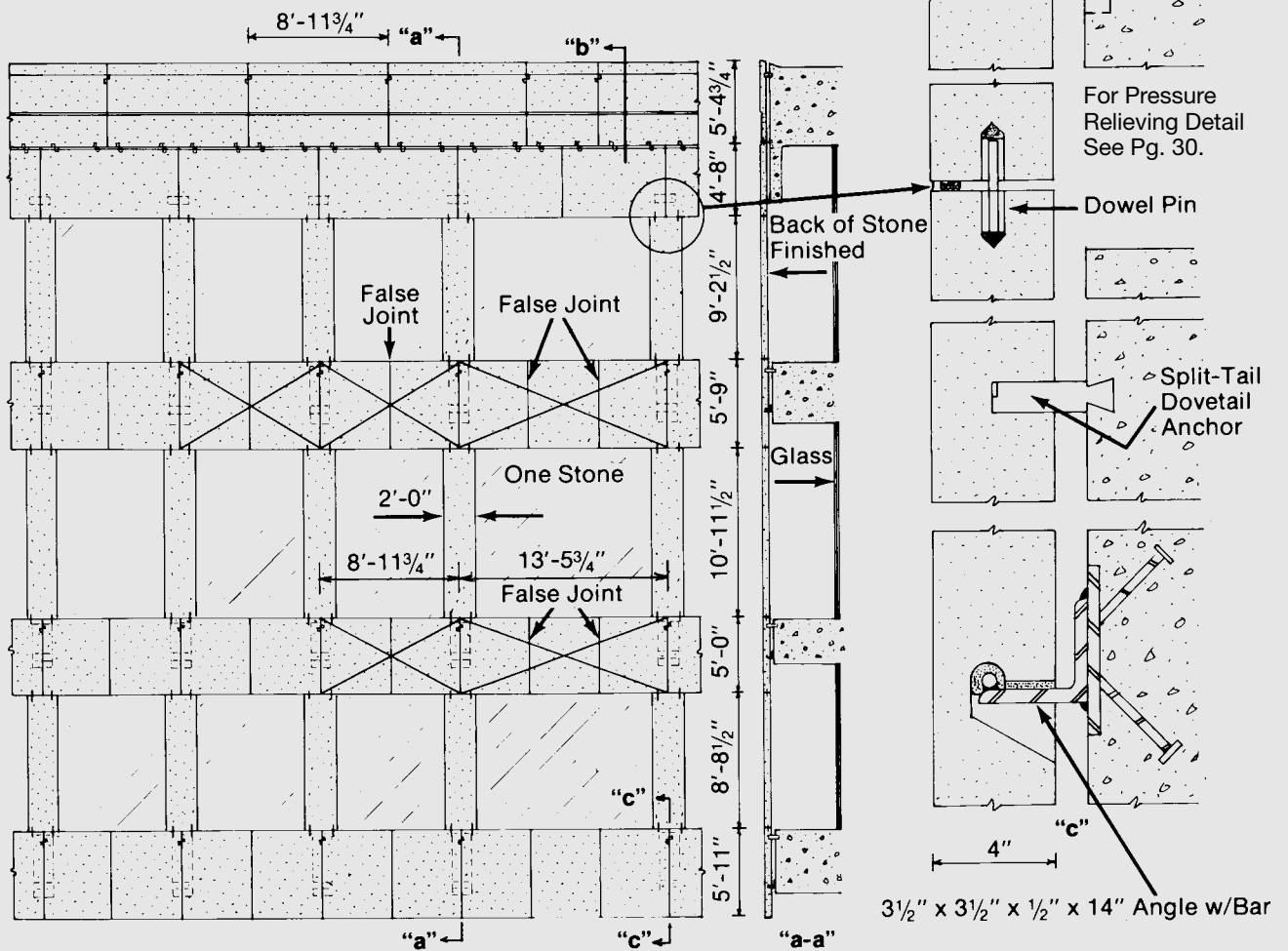

CASE HISTORY

LIMESTONE FOUNTAIN



North Wing Addition
Virginia Museum of Fine Arts, Richmond, Va.

Architects: Hardwicke Associates Inc.
Lawrence Halprin & Associates

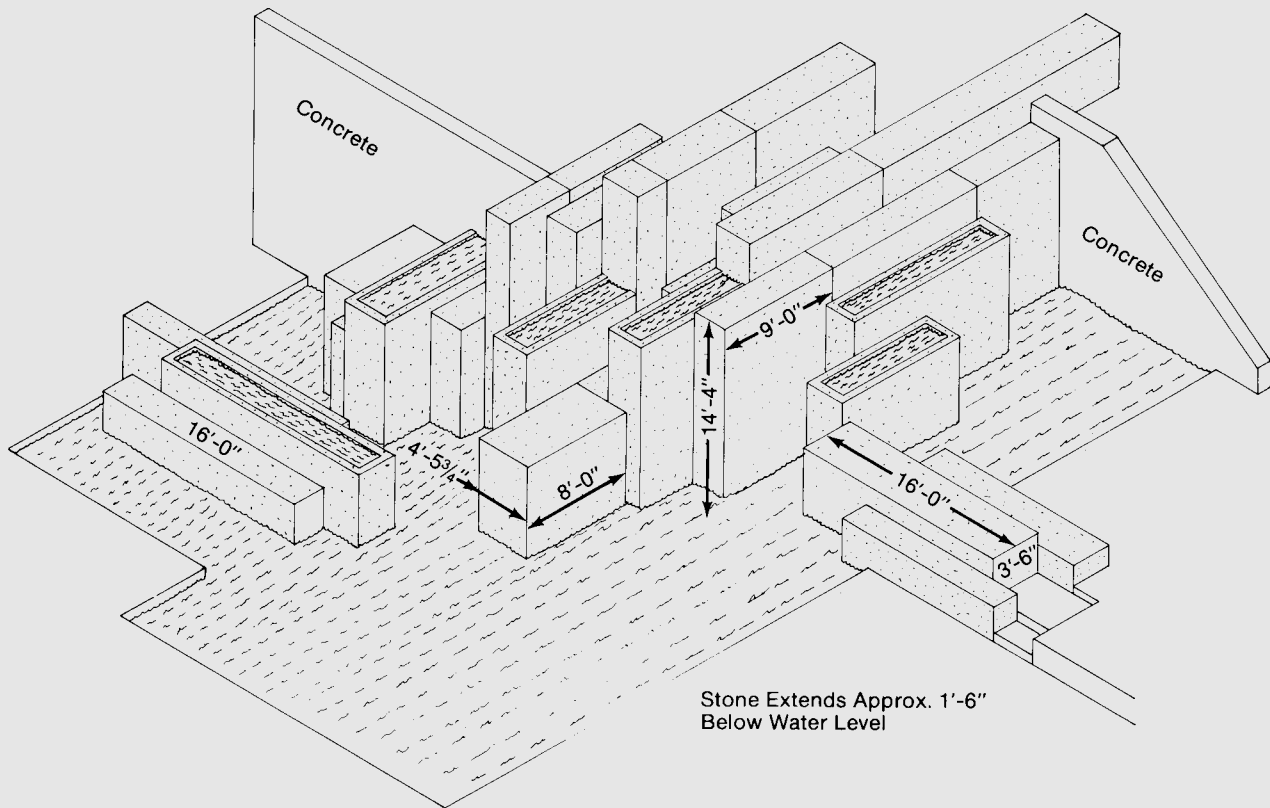

Stones Containing Pools have
Been Epoxy Assembled to Form Pool Area.

CASE HISTORY

HISTORIC RESTORATION

Gate House Stairs • Louisville Water Co., Louisville KY

Alvord • Burdick & Howson • Engineers

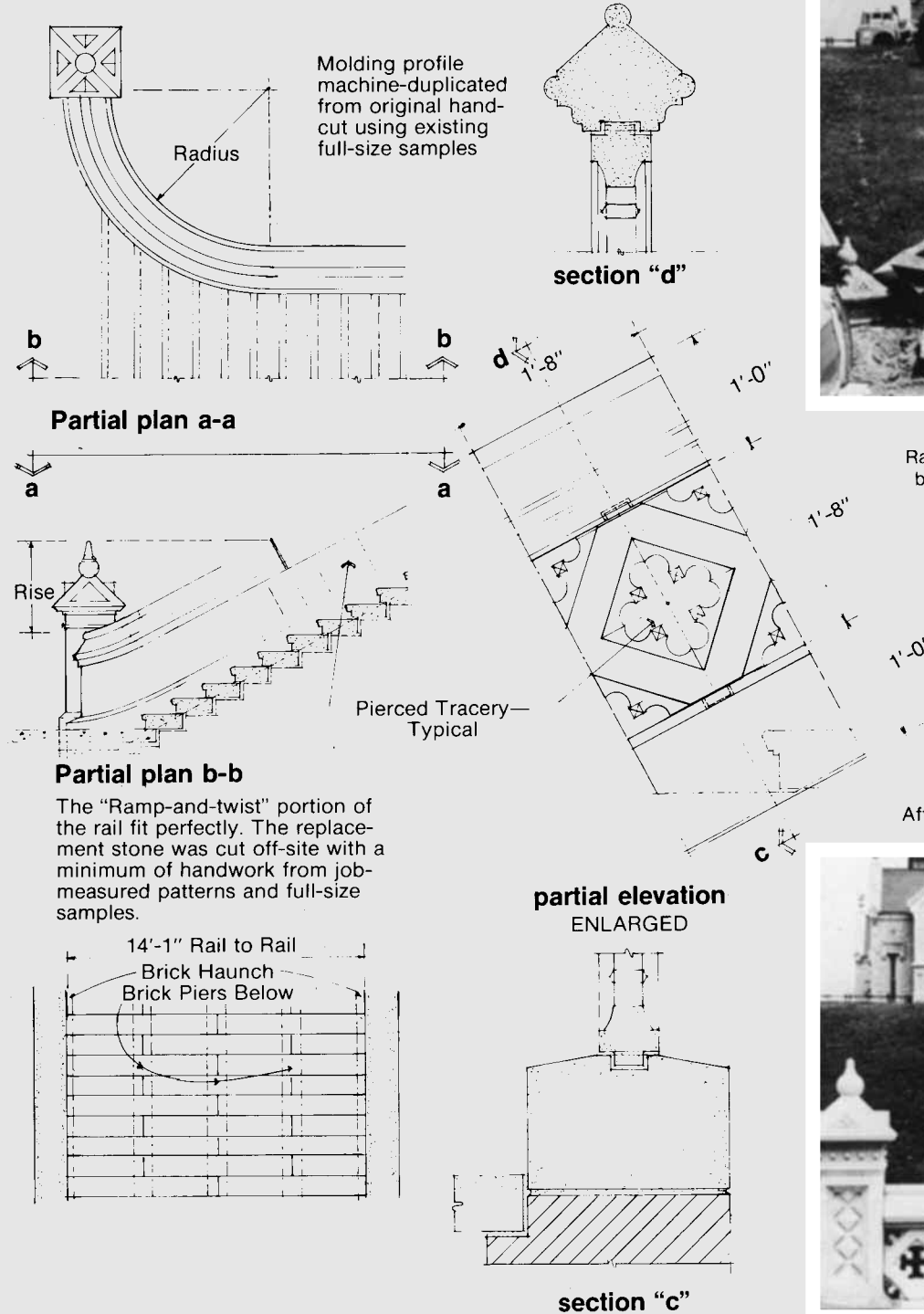

Before.
Rails destroyed
by a tornado.



After Restoration

CASE HISTORY

POST TENSIONED SPANDRELS

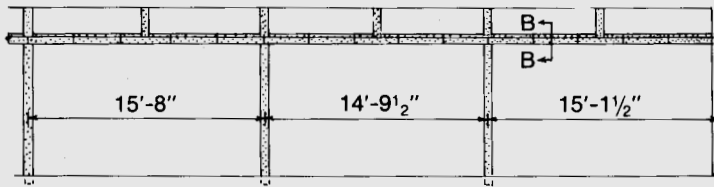
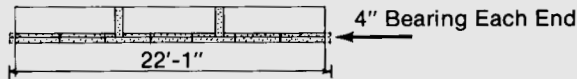
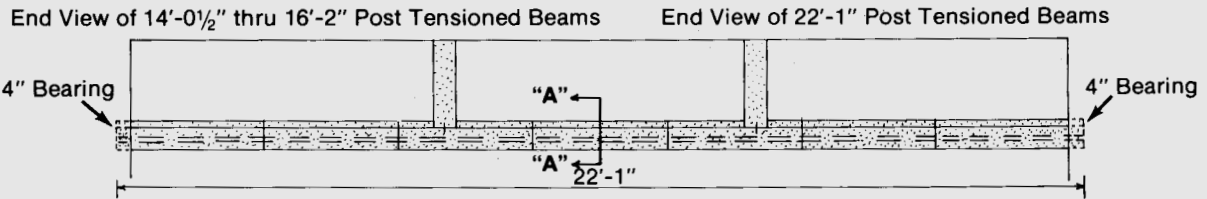
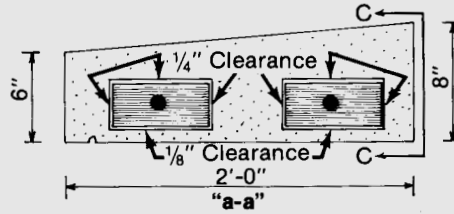
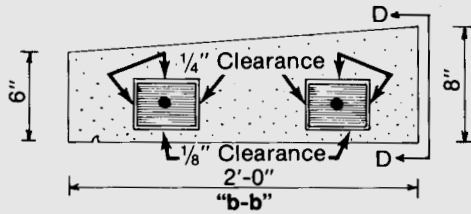
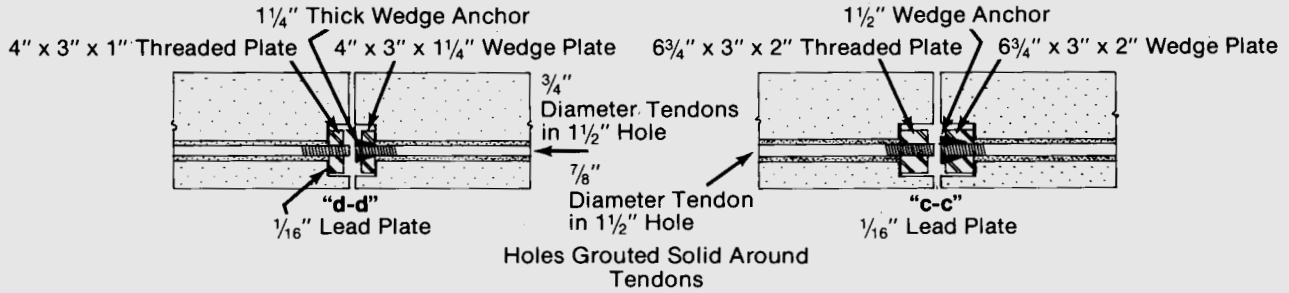

Civic Center
Government Building, Baton Rouge, La.

Architects: Desmond, Miremont, Burks



CASE HISTORY

CONTINUOUS KERF/ALUMINUM SUPPORT SYSTEM



Equitable Tower West
New York, NY

Architects: Edward Larrabee Barnes Associates

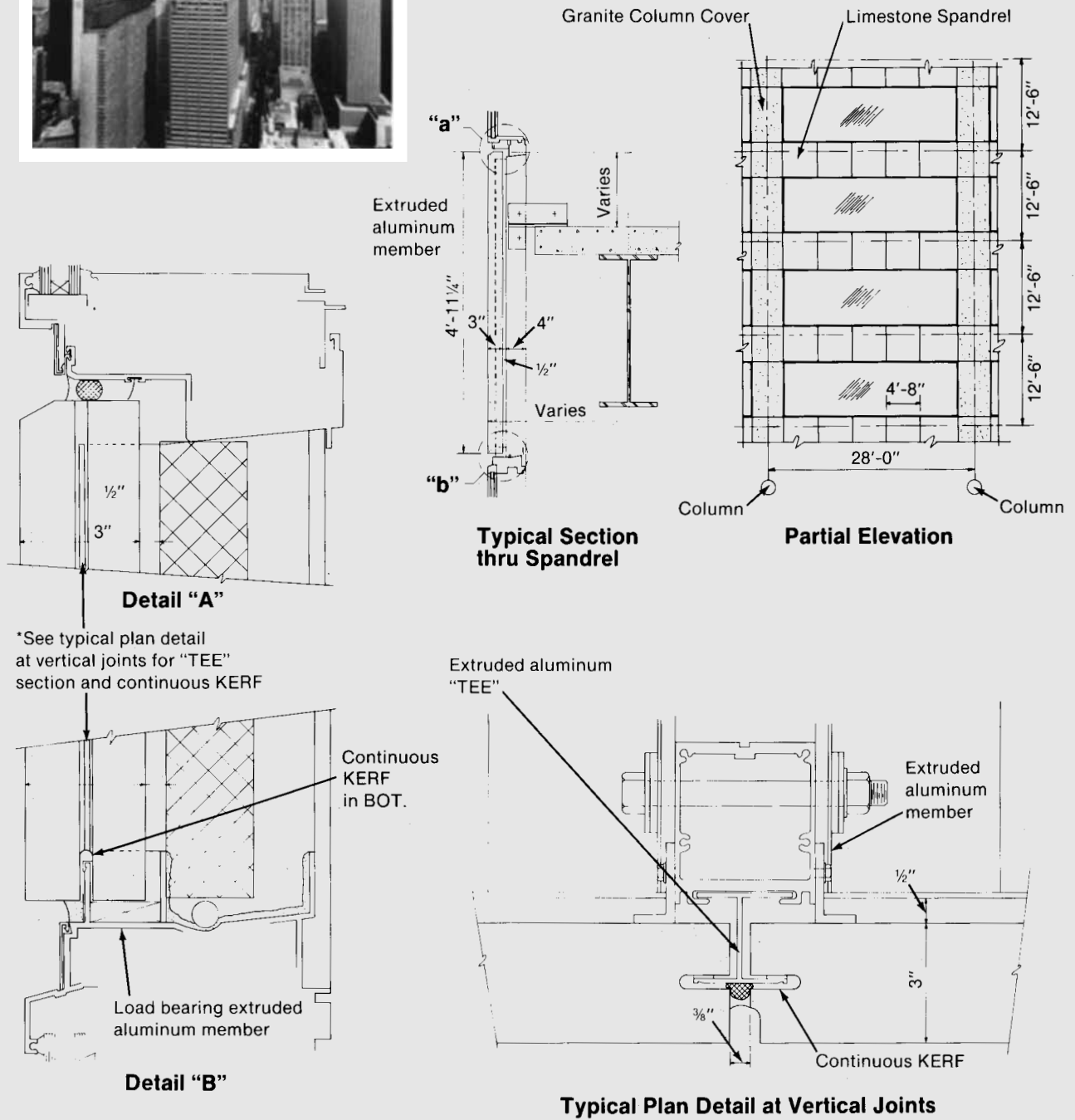

CASE HISTORY

LIMESTONE ON PRECAST



NBC Building
Chicago, IL

Architects: Skidmore, Owings and Merrill

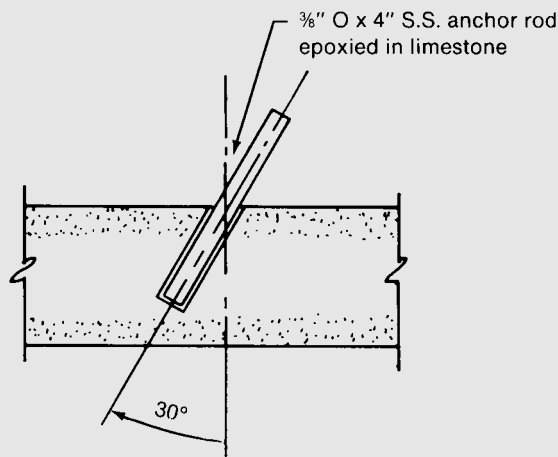

Typical Limestone to Precast Anchor
(Number of anchors per stone varies)

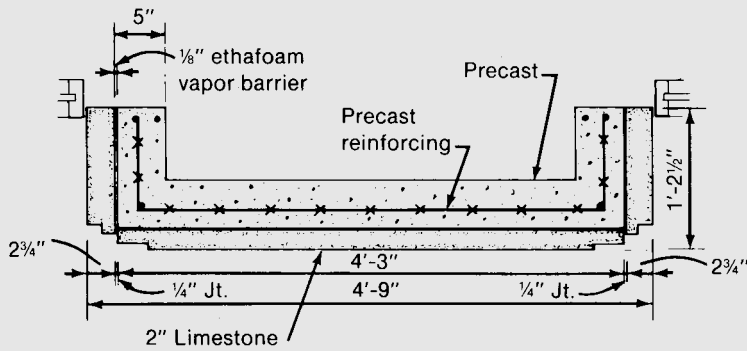

Plan of Typical Column Cover

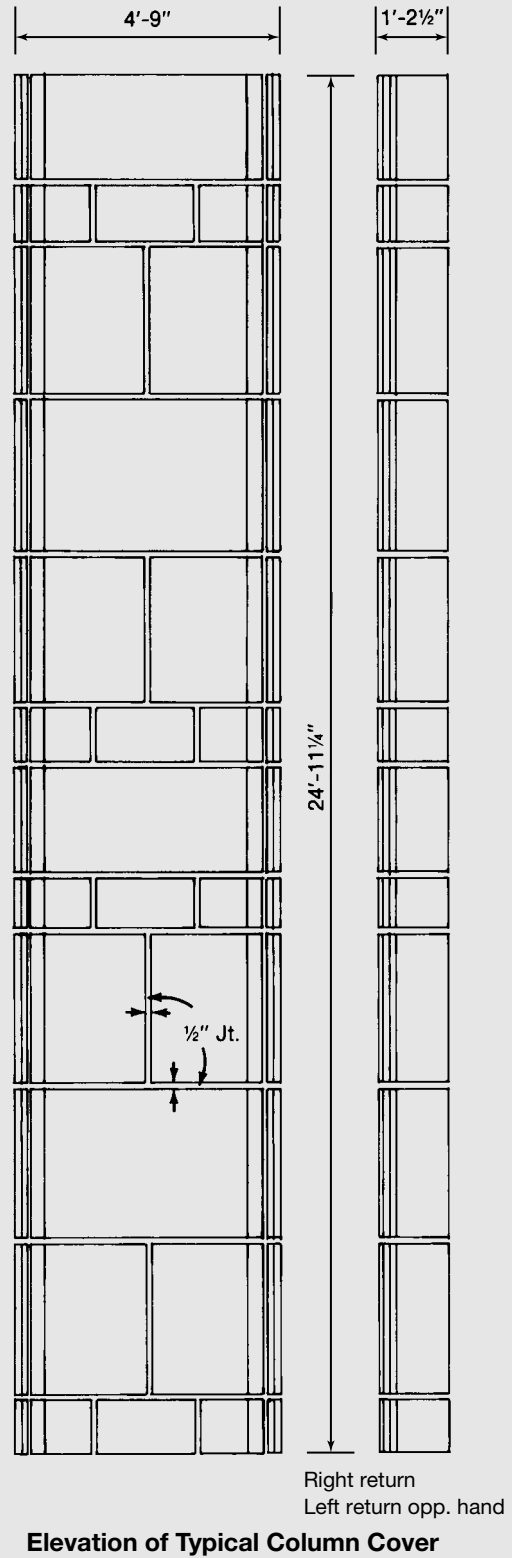



CASE HISTORY

STEEL GIRT SYSTEM

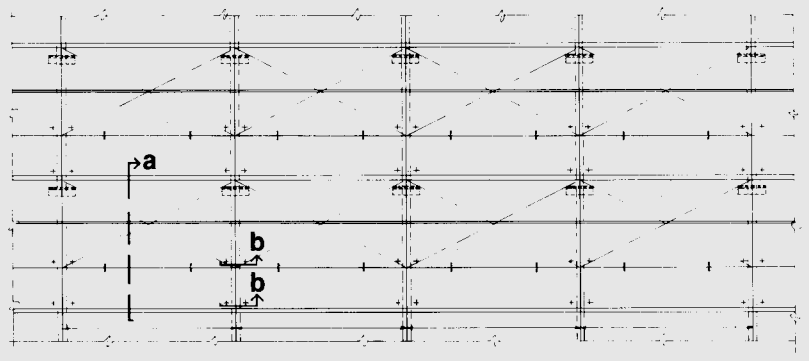
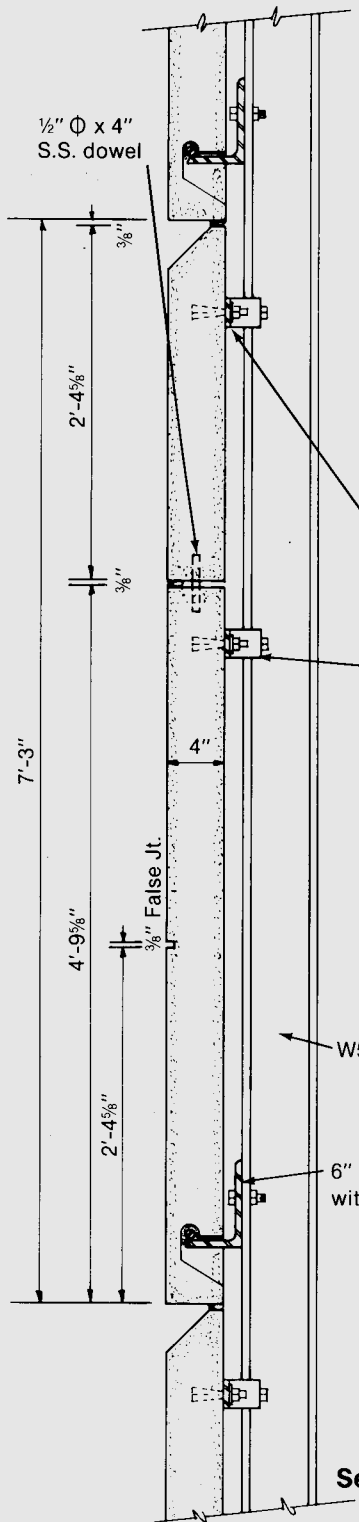

Partial Elevation

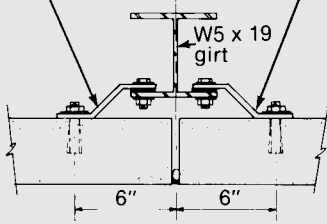

Plan Detail "B"

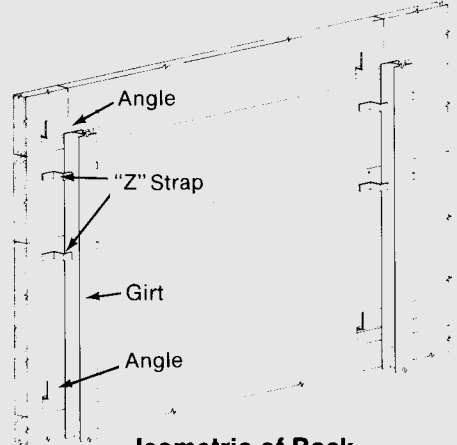

Isometric of Back of Typical Panels

Dallas Museum of Arts
Dallas, TX
Architects: Edward Larrabee Barnes Associates



CASE HISTORY

PREASSEMBLED UNITS



Farm Credit Banks of Wichita
Wichita, KS

Architects: NMT/Walk Jones & Francis Mah

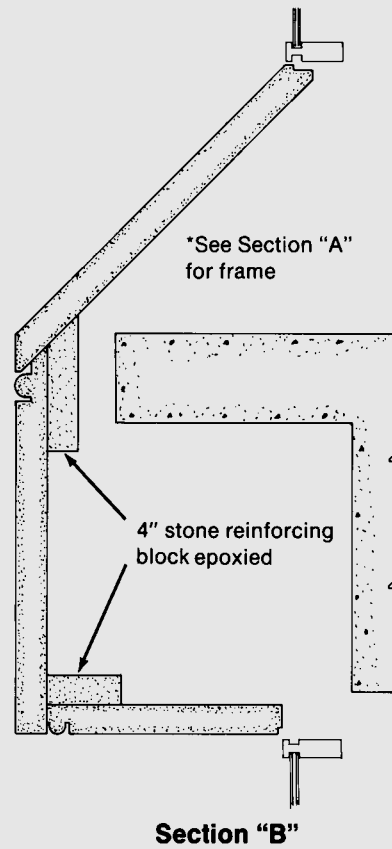
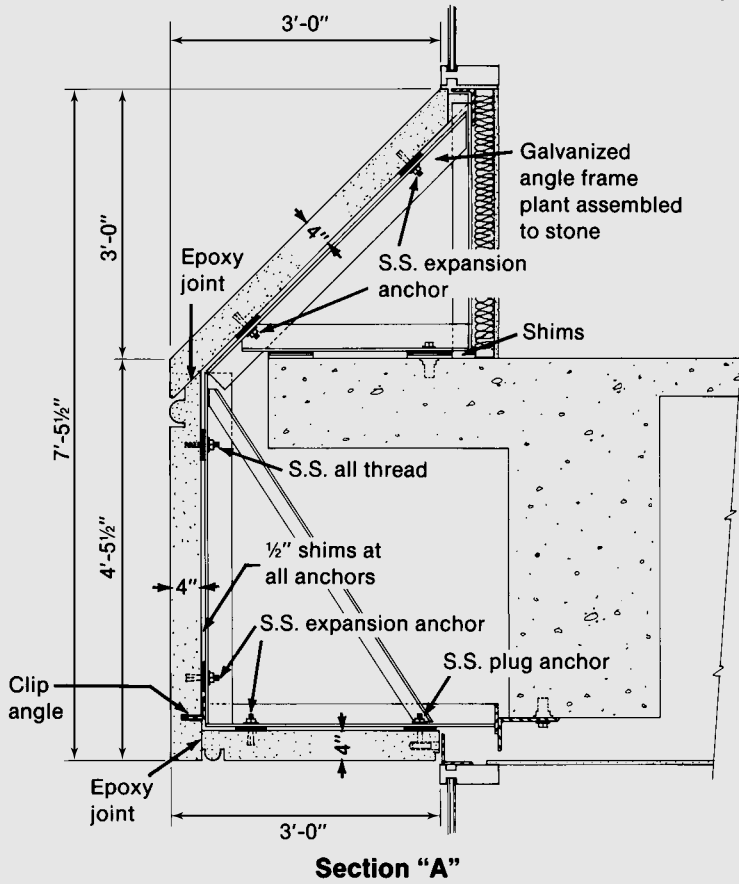
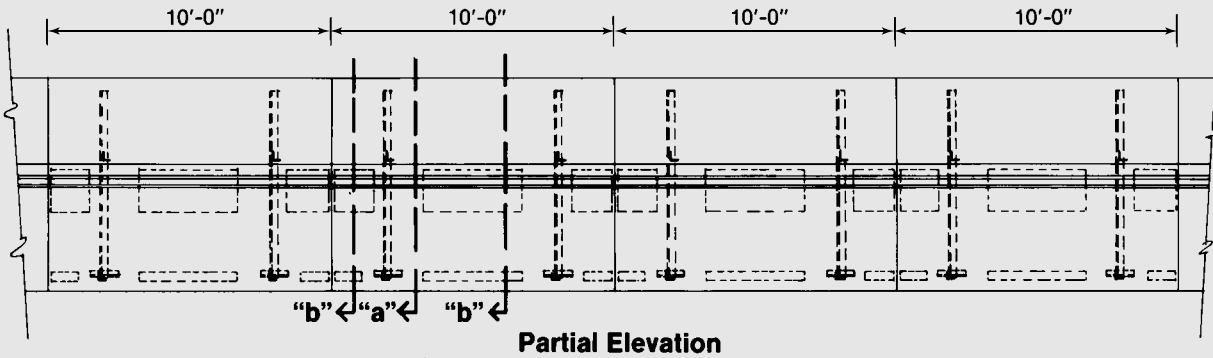



CASE HISTORY

PLANT-INSTALLED SUPPORT FRAMES

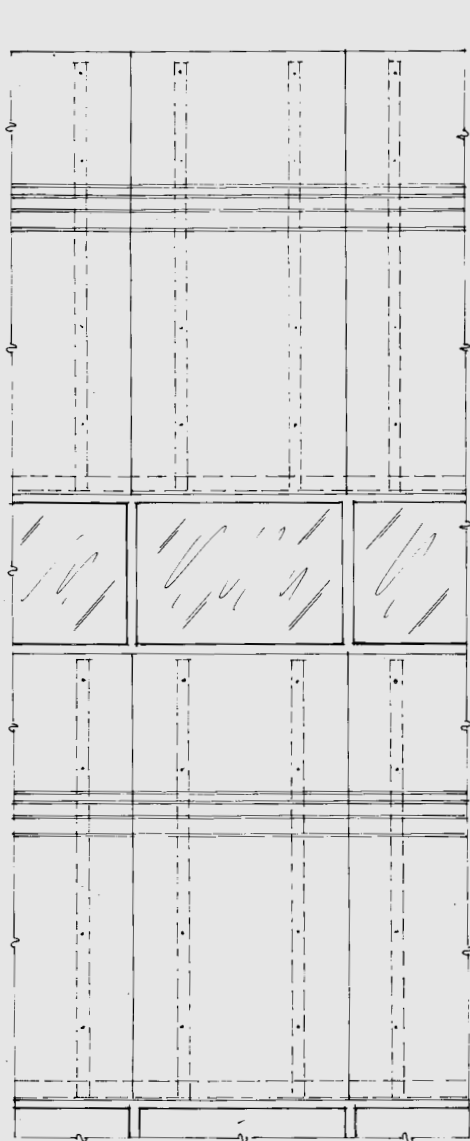

partial elevation

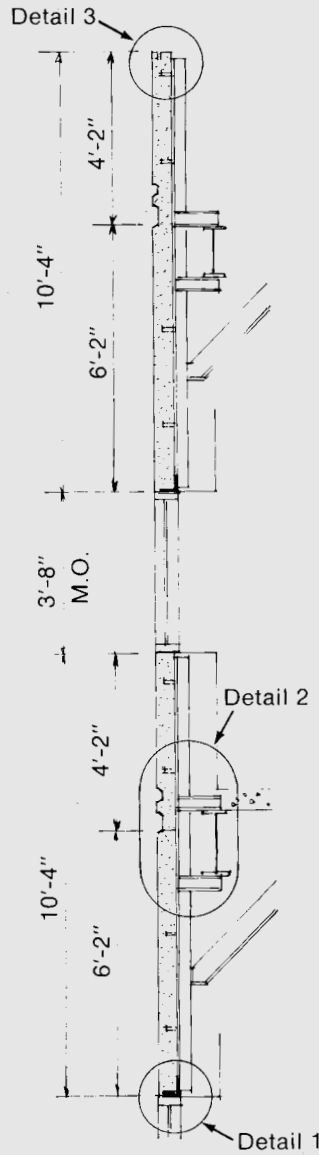

section

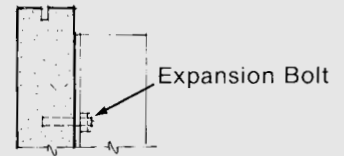

detail 3

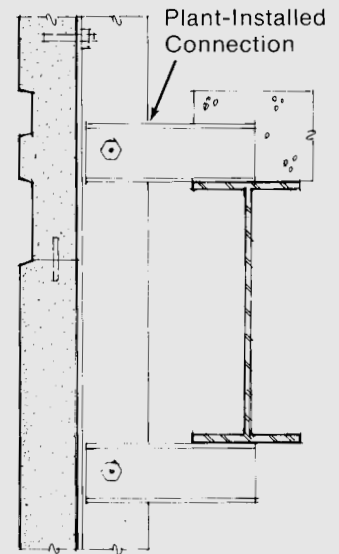

detail 2

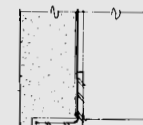

detail 1

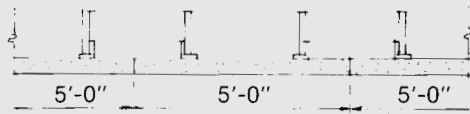

partial plan

Channel 13 WTHR Building
Indianapolis, Indiana

Architects: Browning • Day • Pollak Associates, Inc.



CASE HISTORY

VERTICAL AND HORIZONTAL PLANE CHANGES



American United Life Insurance Building
Indianapolis, Indiana

Architects: Skidmore Owings & Merrill

1/2" Expansion Bolts

Plant-Installed
Connection

Epoxy-Filled Slot

detail 'c'

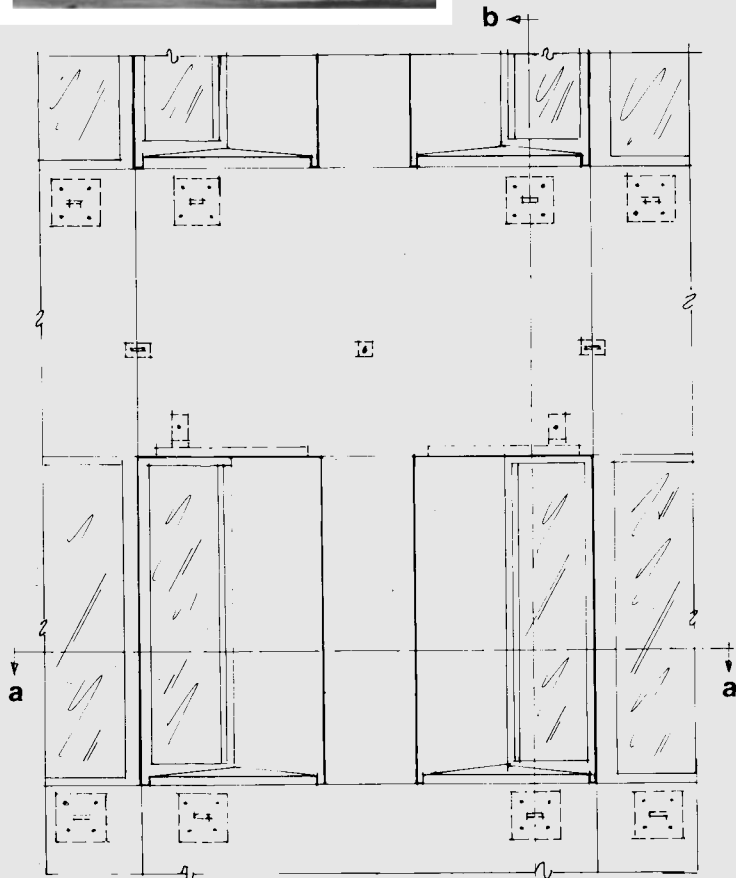

partial elevation b

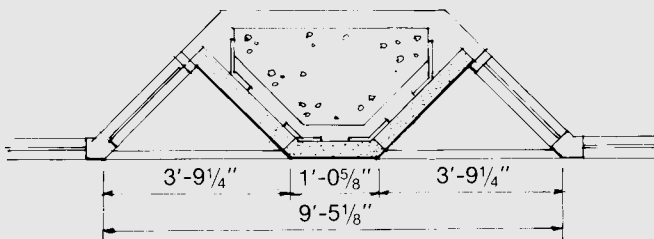

partial plan a-a

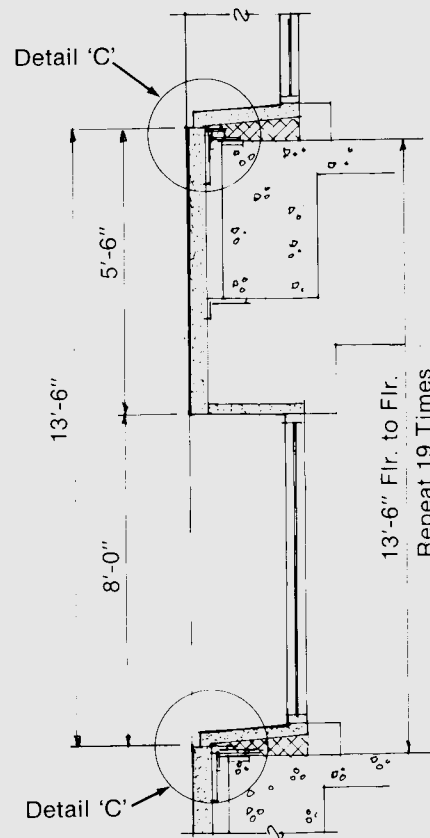

section b-b

SECTION V

specifications, technotes, glossary, index

Specifications for Cut Indiana Limestone	126
Specifications for Setting Cut Indiana Limestone with Mortar Joints	127
Specifications for Erecting Cut Indiana Limestone with Sealant Joints	129
Specifications for Preassembled Units	132
Performance Specifications	133-142
Specifications for Ashlar Stone Veneer and Sawn Stone Trim	142
Technotes	143-151
Glossary	152-153
Index	154

I. SPECIFICATIONS FOR CUT INDIANA LIMESTONE

This section, describing production, should be used with Section II when mortar is the joint closer, or with Section III when sealants are used. If no coursed or rough ashlar is involved (see Section VI), no further specifications are required for limestone in standard masonry buildings.

1. work included

The work under this contract shall include all labor and material necessary to furnish and satisfactorily install the Cut Indiana Oolitic Limestone in accordance with the drawings and as hereinafter specified.

2. description of stone

All limestone specified or shown on drawings shall be Indiana Oolitic Limestone, as quarried in Lawrence, Monroe, and Owen Counties, Indiana. Stone shall be

_____ (Specify grade & color)

and shall have a _____ finish.
(Specify finish)

3. samples

The supplier or fabricator shall submit three (3) samples, ___ x ___" (specify size), for approval by the architect. The samples shall in general be typical of the grade, color and finish specified. This sample and the standards established by the Indiana Limestone Institute shall form the basis of the contract agreement.

4. standard practice

The architect reserves the right to approve the material supplier for cut stone before this portion of the work is awarded. Stone and workmanship quality shall be in accordance with **Industry Standards and Practices** as set forth by the Indiana Limestone Institute of America, Inc., Bedford, Indiana. The stone supplier shall be a member in good standing of that organization.

5. cutting and setting drawings

The cut stone supplier shall prepare and submit to the architect for approval, complete cutting and setting drawings for all of the cut Indiana Limestone work. Such drawings shall show in detail the sizes, sections, and

dimensions of stone, the arrangement of joints and bonding, anchoring and other necessary details. All jointing as shown by the architect on the contract drawings shall be followed, unless modifications are agreed upon in writing, or indicated upon the approved shop drawings. If the contract drawings do not show the intent of the jointing, it will be the fabricator's responsibility to establish the jointing in accordance with industry standards and practices. The general contractor shall furnish all field dimensions necessary for fabrication.

The cutting and setting drawings shall be based upon and follow the drawings and full size details prepared by the architect except where it is agreed in writing or shown on the approved shop drawings that changes be made. Each stone indicated on the setting drawings shall bear the corresponding number marked on an unexposed surface.

Provision for the anchoring, dowelling, and cramping of work, in keeping with standard practices, and for the support of stone by shelf angles and loose steel, etc., when required, shall be clearly indicated on the cutting and setting drawings.

6. carving and models

All carving shall be done by skilled carvers in a correct and artistic manner, in strict accordance with the spirit and intent of the approved shaded drawings, or from models furnished or approved by the architect.

7. cutting

All stone shall be cut accurately to shape and dimensions and full to the square, with jointing as shown on approved drawings. All exposed faces shall be dressed true. Beds and joints shall be at right angles to the face, and joints shall have a uniform thickness of $\frac{3}{8}$ " unless otherwise shown or noted on drawings.

Reglets for flashing, etc., shall be cut in the stone where so indicated on the drawings.

Molded work shall be carefully executed from full size details supplied by architect, and must match satisfactorily at joints. All exposed arrises shall be in true alignment and slightly eased to prevent snipping.

8. repairing damaged stone

Repair of stone is an accepted practice and will be permitted. Some chipping is expected; repair of small chips is not required if it does not detract from the overall appearance of the work, or impair the effectiveness of the mortar or sealant. The criteria for acceptance of chips and repairs will be per standards and practices of the industry unless other criteria are mutually agreed upon by the limestone supplier and the architect.

9. back-checking and fitting to structure or frame

Stone coming in contact with structural work shall be back-checked as indicated on the approved shop drawings. Stones resting on structural work shall have beds shaped to fit the supports as required.

Maintain a minimum of 1" between stone backs and adjacent structure. (**Note:** many bolted connections will require more space than this; 2" space may be more desirable. Large-scale details should illustrate and control these conditions.)

10. cutting for anchoring, supporting, and lifting devices

Holes and sinkages shall be cut in stones for all anchors, cramps, dowels and other tie-back and support devices per industry standard practice and/or approved shop drawings. However, expansion anchor holes shall be drilled at jobsite by mason or erector to facilitate alignment.

No holes or sinkages will be provided for contractor's handling devices unless arrangement for this service is made by the contractor with the stone supplier.

Note: It is not recommended that Lewis pins be used for stones less than 3¹/₂" thickness.

11. cutting and drilling for other trades

Any miscellaneous cutting and drilling of stone necessary to accommodate other trades will be done by the cut stone fabricator only when necessary information is furnished in time to be shown on their shop drawings and details, and when work can be executed before fabrication. Cutting and fitting, due to jobsite conditions, will be the responsibility of the general contractor.

Incidental cutting such as for window frame clips, etc., which is normally not considered to be the responsibility of the stone supplier, will be provided only by arrangement by the contractor with the stone supplier.

12. loading and shipment

The cut Indiana Limestone shall be carefully packed for transportation with exercise of all customary and reasonable precautions against damage in transit. All cut stone under this contract shall be loaded and shipped in the sequence and quantities mutually agreed upon by the general contractor or erector and the material supplier.

13. unloading and storage at jobsite

All stone shall be received and unloaded at the site with necessary care in handling to avoid damaging or soiling.

Stone shall be stored clear of the ground on nonstaining skids (cypress, white pine, poplar, or yellow pine without an excessive amount of resin). Chemically treated wood should not be used. DO NOT use chestnut, walnut, oak, fir, and other woods containing tannin.

Stone shall be covered with waterproof paper, clean canvas or polyethylene.

II. SETTING CUT INDIANA LIMESTONE (WITH MORTAR)

This section describes the setting and further handling of limestone where mortar joints are used. In conjunction with Section I, no further stone sections are necessary for specifying hand-set cut stone.

14. work included

The work under this contract shall include all labor and materials necessary for the satisfactory installation of cut Indiana Limestone in accordance with the provisions set out herein.

15. setting mortar

Setting mortar shall be ASTM C-270 Type N (indicate other type if desired) composed of (select:) one part portland cement, one part mason's lime, and six parts sand mixed with potable water (or:) one part masonry cement and two and three-fourths part sand mixed with potable water.

16. pointing mortar

Pointing mortar shall be composed of one part (white or other) portland cement, one part hydrated lime, and six parts white sand passing a #16 sieve.

17. expansion joints

Joints shall be adequate to allow for thermal and structural differential movement. Filler material for these joints shall be nonstaining.

18. weeps

Plastic or other weep tubes, or felt wicks, shall be placed in joints where moisture may accumulate within the wall, such as at base of cavity, continuous angles, flashing, etc., or as shown on architectural drawings.

19. stone anchors and attachments

Provide anchors and attachments of type and size required to support the stonework fabricated from the following metals for conditions indicated below:

Stainless Steel, AISI Type 304 or 316, for anchors and expansion bolts embedded within the stone.

Hot-Dip Galvanized Steel as follows:

Galvanized malleable iron for adjustable inserts embedded in the concrete structure.

For anchor bolts, nuts and washers not in direct contact with stone; comply with ASTM A 307, Grade A, for material and ASTM C 153, Class C, for galvanizing.

For steel plates, shapes and bars not in direct contact with stone; comply with ASTM A 36 for materials and ASTM A 123 for galvanizing.

For expansion bolts not in direct contact with stone use zinc plated or cadmium plated bolts with stainless steel expansion clips.

For steel angles supporting limestone; comply with ASTM A 36 for materials and ASTM A 123 for galvanizing. Supports protected with one shop coat of zinc-rich or other rust-inhibiting paint, and one job coat of similar, compatible paint, may be used at the discretion of the architect.

20. dampproofing for stain prevention:

Where indicated on drawings, coatings of either (a) cementitious waterproof stone backing or (b) bituminous dampproofing shall be applied on backs, beds, and joints of all stones used at grade. Dampproof all adjacent concrete surfaces on which limestone will rest, including concrete or cmu haunches and ledges, as well as support angles.

A. Dampproof unexposed surfaces of stone to at least 1'-0" above grade.

B. Dampproof joints only to within 1" of finished surfaces when using bituminous or asphaltic solutions.

C. Stones extending below grade shall be dampproofed as above, and in addition shall be dampproofed to the level of grade on their face surfaces which are covered.

D. Cementitious coatings must be allowed to cure before treated stone is set. Due care must be exercised in handling all dampproofed stone to avoid chipping or off-setting.

21. setting

A. All Indiana Limestone shall be set accurately in strict accordance with the contract and shop drawings.

B. When necessary, before setting in the wall, all stones shall be thoroughly cleaned on all exposed surfaces by washing with fiber brush and soap powder, followed by a thorough drenching with clear water.

C. All stone joint surfaces not thoroughly wet shall be drenched with clear water just prior to setting.

D. Except as otherwise specially noted, every stone shall be set in full beds of mortar with all vertical joints slushed full. Completely fill all anchor, dowel, and similar holes. Unless otherwise noted, all bed and joint widths shall be $\frac{3}{8}$ ".

E. Lead or plastic setting pads shall be placed under heavy stones, column drums, etc., in same thickness as joint, and in sufficient quantity to avoid squeezing mortar out. Heavy stones or projecting courses shall not be set until mortar in courses below has hardened sufficiently to avoid squeezing.

F. Joints can be tooled when initial set has occurred, or raked out 1" and pointed later. If pointed with sealant, the raked depth and sealant applications shall conform to manufacturer's instructions. (See p. 25.)

G. Projecting stones shall be securely propped or anchored until the wall above is set.

H. Only the ends of lugged sills and steps shall be embedded in mortar. Balance of joint shall be left open until finally pointed.

I. All cornice, copings, projecting belt courses, other projecting courses, steps, and platforms (in general, all stone areas either partially or totally horizontal) should be set with unfilled vertical joints. After setting, insert properly sized backup material or backer rod to proper depth, and gun in sealant. (See p. 25 and the following specification section for more information on sealant joints.)

J. In cold weather, International Masonry Industry All-Weather Council recommendations for setting from 40 degrees to 20 degrees F shall be followed, except that no additives shall be used in the setting mortar, and below 20 degrees F all work shall be done in heated enclosures.

22. protection of finished work

A. Receipt, storage, and protection of cut stonework prior to, during and subsequent to installation shall be the responsibility of the mason contractor.

B. During construction, tops of walls shall be carefully covered at night, and especially during any precipitation or other inclement weather.

C. At all times, walls shall be adequately protected from droppings.

D. Whenever necessary, substantial wooden covering shall be placed to protect the stonework. Nonstaining building paper or membrane shall be used under the wood. Maintain all covering until removed to permit final clearing of the stonework.

23. cleaning

The stone shall be washed with fiber brushes, mild soap powder or detergent and clean water or approved mechanical cleaning process.

Special consideration and protection shall be provided when brickwork is cleaned above the limestone. Strong acid compounds used for cleaning brick will burn and discolor the limestone.

Use of sand blasting, wire brushes or acids will only be permitted under special circumstances, approved by architect.

III. ERECTING CUT INDIANA LIMESTONE (WITH SEALANT JOINTS)

This section is used in conjunction with Section I, when the primary joint closing material will be sealant in lieu of mortar. One of these combinations (Section I with either Section II or III) is usually the only specification required for hand-set cut stone applications in standard or traditional masonry construction. (Users may wish to refer to ILI Technote on Joint Sealants for Indiana Limestone.)

14. work included

The work under this contract shall include all labor and materials necessary for the satisfactory installation of cut Indiana Limestone in accordance with the provisions set out herein.

15. joint sealants

A. Joint Sealant (specify type)

1. Multicomponent polysulfide or polyurethane as per Federal Specification TT-S-00227e (Com-NBS) Amendment-3, October 9, 1970, Type II, NonSag, Class B and A.S.A. Specification A116.1 (1967).

2. One part polysulfide meeting Interim Federal Specification TT-S-00230c, Type II (Com-NBS) Amendment-2, October 9, 1970.

3. One part acrylic polymeric sealant as per U.S. Federal Specification TT-S-00230c, Type II (Com-NBS) Amendment, October 1, 1970. (Use of acrylics should be limited to those joints where anticipated movement is minimal.)

4. One or two parts Silicone as per Federal Specifications TT-S-001543 (Com-NBS) Amendment.

5. One part Hypalon Sealant as per U.S. Federal Specifications TT-S-00230 (Com-NBS), February 2, 1970, Type II, Class B.

6. One part Polyurethane as per Federal Specification TT-S-00230c, Type II.

B. Primer, when required, shall be nonstaining and nonacidic, and shall be used as recommended by manufacturer of sealant in writing to architect, having been tested before for staining and durability on samples of actual surfaces to be sealed.

(If primers are required, *they should be applied to the confines of joint surfaces* after stone is installed into the wall. In some instances it may be advisable to apply primer to the stone before the stone is installed into the wall. Application procedures should be as recommended by manufacturer of the sealant, in writing, to the architect.)

C. Backup materials and preformed joint fillers shall be nonstaining, compatible with sealant and primer, and of a resilient nature, such as closed cell resilient foam, sponge rubber, or of a supporting type, such as closed cell rigid foam, cork or non-impregnated fiberboard. Materials impregnated with oil, bitumen or similar materials shall not be used. Size and shape shall be as indicated by joint detail in drawings.

Sealant shall not adhere to backup material and shall be as recommended by sealant manufacturer in writing to architect.

D. Bond breakers, when required, shall be (polyethylene tape)—(other) as recommended by manufacturer of sealant in writing to architect.

E. Solvents, cleaning agents and other accessory materials shall be nonstaining to Indiana Limestone and shall be recommended by sealant manufacturer in writing to the architect.

16. expansion and control joints

Joints shall be adequate to allow for thermal and structural differential movement. Filler material for these joints shall be nonstaining and compatible with the sealing compound.

17. weep systems

Plastic or other weep tubes, or felt wicks, shall be placed in joints where moisture may accumulate within the wall, such as at base of cavity, continuous angles, flashing, etc., or as shown on architectural drawings.

18. stone anchors and attachments

Provide anchors and attachments of type and size required to support the stonework fabricated from the following metals for conditions indicated below:

Stainless Steel, AISI Type 304 or 316, for anchors and expansion bolts embedded within the stone.

Hot-Dip Galvanized Steel as follows:

Galvanized malleable iron for adjustable inserts embedded in the concrete structure.

For anchor bolts, nuts and washers not in direct contact with stone; comply with ASTM A 307, Grade A, for material and ASTM C 153, Class C, for galvanizing.

For steel plates, shapes and bars not in direct contact with stone; comply with ASTM A 36 for materials and ASTM A 123 for galvanizing.

For expansion bolts not in direct contact with stone use zinc plated or cadmium plated bolts with stainless steel expansion clips.

For steel angles supporting limestone; comply with ASTM A 36 for materials and ASTM A 123 for galvanizing. Supports protected with one shop coat of zinc-rich or other rust-inhibiting paint, and one job coat of similar, compatible paint, may be used at the discretion of the architect.

19. dampproofing for stain prevention:

Where indicated on drawings, coatings of either (a) cementitious waterproof stone backing or (b) bituminous dampproofing shall be applied on backs, beds,

and joints of all stones used at grade. Dampproof all adjacent concrete surfaces on which limestone will rest, including concrete or cmu haunches and ledges, as well as support angles.

A. Dampproof unexposed surfaces of stone to at least 1'-0" above grade.

B. Dampproof joints only to within 1" of finished surfaces when using bituminous or asphaltic solutions.

C. Stones extending below grade shall be dampproofed as above, and in addition shall be dampproofed to the level of grade on their face surfaces which are covered.

D. Cementitious coatings must be allowed to cure before treated stone is set. Due care must be exercised in handling all dampproofed stone to avoid chipping or off-setting.

20. setting procedures and conditions

A. All Indiana Limestone shall be set accurately in strict accordance with the contract and shop drawings.

B. When dictated by the condition of the stone prior to setting, all Indiana Limestone shall be thoroughly cleaned with fiber brushes and soap powder before erection. Otherwise, stone shall be cleaned after erection. Power cleaning systems which will not harm stone or joints may be used.

C. Limestone shall be set on concrete, clip angles or continuous angles bedded in mortar. Lead setting pads or other setting shims, buttons, or sheets of resilient, low-durometer material approved by the architect may be used in lieu of or in combination with mortar. Where load-bearing joints occur between stones (that is, joints without concrete or steel support areas), similar bedding materials shall be used to support the load and to maintain joint width. Unless otherwise noted, all bed and joint widths shall be $\frac{3}{8}$ ".

D. Mortar joints shall be raked back sufficiently to accept backup material or bond breaker plus sealant bead. Apply no sealant directly against mortar.

E. Fill all anchor slots, dowel holes, and other sinkages with mortar, lead wool, sealant, approved shim or other material.

21. workmanship, installation

A. General

1. Use contractors specializing in the application of sealants and apply in conformance with manufacturer's written directions.

2. Sealant contractor shall examine all other work surfaces and joint dimensions to receive the work of this section and report to the general contractor all conditions not acceptable.

3. All joint surfaces shall be neatly pointed or tooled to provide the contour as indicated on drawings.

4. For application of sealant when air temperature is below 40 degrees F or above 95 degrees F, consult sealant manufacturer for recommendations.

B. Preparation

1. Thoroughly clean all joints, removing all foreign matter such as dust, oil, grease, water, surface dirt, and frost. Sealant must be applied to the clean joint surface or primer.

2. Stone should be cleaned where necessary by grinding (sand-water) blast-cleaning, mechanical abrading, or a combination of these methods as required to provide a clean, sound base surface for sealant adhesion.

(a) Loose particles present or resulting from grinding, abrading, or blast-cleaning shall be removed (by blowing out joints with oil-free compressed air or vacuuming joints) prior to application of primer or sealant.

3. All joints to receive sealant shall be as indicated on architectural drawings. Do not seal joints until they are in compliance with drawing, or meet with the approval of the architect.

(a) Joints to receive sealant and backing shall be a minimum of $\frac{3}{8}$ " wide by no more than $\frac{3}{8}$ " deep, unless otherwise approved.

(b) Depth of the sealant may be equal to the width in joints up to $\frac{1}{2}$ " wide. For expansion and other joints $\frac{1}{2}$ " to 1" wide, depth shall not be greater than $\frac{1}{2}$ the applied sealant width. For joints exceeding 1" in width, depth shall be $\frac{3}{4}$ " maximum or as directed by sealant manufacturer. For joints exceeding 2" in width, depth shall be as directed by sealant manufacturer.

4. Joints to receive sealant, backup material or preformed joint filler shall be cleaned out and raked to full width and depth as required by sealant contractor or others.

5. Joints shall be of sufficient width and depth to accommodate specified backup material or preformed joint filler, and sealant. Limestone shall be free of water repellents and other surface treatments. If there is a question that surface treatment may be present, contact sealant manufacturer for test for adhesion before proceeding with the sealant work.

C. Application

1. Install backup material or joint filler, of type and size specified, at proper depth in joint to provide sealant

dimensions as detailed. Backup material shall be of suitable size and shape so that, when compressed (25% to 50%), it will fit in joints as required. Sealant shall not be applied without backup material and, if necessary, bond breaker strip. Use specified bond breaker strip between sealant and supporting type backup material. Bond breaker strip shall be used in all joints where sufficient depth for backup does not exist. (**Note:** Closed-cell polyethylene may cause gas bubbles in sealant bead if compressed in excess of 25%.)

2. Apply masking tape, where required, in continuous strips in alignment with joint edge. Remove tape immediately after joints have been sealed and tooled as directed.

3. Prime surfaces, where required, with primer as recommended by sealant manufacturer.

4. Follow sealant manufacturer's instructions regarding mixing, surface preparation, priming, application life, and application procedure.

5. Apply, tool, and finish sealant as required. When tooling white or light colored sealants, use (clean water-wet or dry) tool or tooling solution recommended by sealant manufacturer.

6. Clean adjacent surfaces free of sealant or soiling resulting from this work as work progresses. Use solvent or cleaning agent, nonstaining to limestone, as recommended by sealant manufacturer. All finished work shall be left in a neat, clean condition.

22. protection of finished work

A. Receipt, storage, and protection of cut stonework prior to, during, and subsequent to installation shall be the responsibility of the general contractor.

B. During construction, tops of walls shall be carefully covered at night, and especially during any precipitation or other inclement weather.

C. Whenever necessary, substantial wooden covering shall be placed to protect the stonework. Nonstaining building paper or membrane shall be used under the wood. Maintain all covering until removed to permit final clearing of the stonework.

23. cleaning

The stone shall be washed with fiber brushes, soap powder and clean water or approved mechanical cleaning process.

Special consideration and protection shall be provided when brickwork is cleaned above the limestone. Strong acid compounds used for cleaning brick may burn and discolor the limestone.

Use of sand blasting, wire brushes or acids will only be permitted under special circumstances, approved by architect.

IV. SPECIFICATIONS FOR UNITS PREASSEMBLED WITH THERMO-SETTING RESIN

This section describes the fabrication of pre-assembled stone panels. It may be used by itself, in those cases where no hand-set stone is required. If a more complete description of the milling process is desired, this section may be used with Section I. Typically, the joints within preassembled stone units are closed with adhesive. Joints between units are closed with sealant. Refer to Section III.

14. work included

The work under this contract shall include all labor and material for furnishing the assemblies of Indiana Limestone in accordance with the drawing and specifications, using high-strength adhesives and mechanical connections when required.

15. stone

Units shall be constructed of Indiana Limestone quarried in Lawrence, Monroe, and Owen Counties, Indiana. Stone shall be _____

(Specify grade & color)

and shall have a _____ finish.

(Specify finish)

16. adhesive

The adhesive shall be a two-component epoxy consisting of epoxy resin, hardener, inert mineral filler and

thixotropic agent. The filler content shall not exceed 50% of the total composition by weight.

17. qualifications

The adhesive used shall meet the following minimum requirements after a 7-day cure at 75 degrees F:

18. samples

Two sample units of stone bonded together with adhesive shall be submitted showing stone and joint quality. Samples shall be 6" long, 3" wide, 3/4" thick, bonded together on the large face, at right angles. No fabrication or assembly shall begin until approval of sample is obtained.

Property	Value	Test Method
Tensile Bond Strength*	Cohesive failure in stone	ASTM C-321
Tensile Elongation	2.5%	ASTM D-638
Tensile Strength	3,500 psi	ASTM D-638
Compressive Double Shear*	400 psi	MMM G-650A
Compressive Strength	6,000 psi	ASTM D-695
Shore "D" Hardness	75	ASTM D-1706
Water Absorption (24 hours)	0.50%	ASTM D-570

*Note: These tests represent bond strength. Other tests are made on the adhesive only.

Note: Accepted industry practice allows 1/8" adhesive joints.

19. drawings

The stone fabricator shall submit to the architect for approval detailed drawings showing the epoxy joint construction he proposes to use, including mechanical anchoring.

20. shop assembly requirements

A. Stone must be dry and free from grease, oil, dirt, loose particles, and efflorescence. Clean compressed air should be employed to blow stone dust from the pores of the stone. Artificial heat is recommended for the removal of moisture from the stone which has not had the opportunity to dry following fabrication. No

moisture should be observed creeping into areas to be bonded following the removal of artificial heat.

B. Units shall not be assembled when the stone temperature and the surrounding air temperatures are below 50 degrees F or above 95 degrees F. Assembly of units below 50 degrees F is permitted when the temperature of the stone units and the adhesive is raised by artificial heating to a temperature above 50 degrees F. After the units have been joined, artificial heat should continue to be applied to the stone adjacent to the joint area to give the adhesive the curing temperature above 50 degrees F. Approved clips, frames, expansion bolts, and other mechanical connections are installed during this process in strict accordance with approved shop drawings.

C. Adhesives shall be mixed in parts by weight or parts by volume in strict accordance with manufacturer's instructions, with strict compliance to the manufacturer's recommendations on the "pot life" of the adhesive.

D. Upon joining the stone members together, use suitable clamps or bracing to maintain proper alignment until the adhesive sufficiently hardens.

E. Assembled limestone units shall not be moved until the adhesive has cured sufficiently to assure that there will be no joint slippage. Curing shall continue until tests indicate that the adhesive has reached the required hardness (Shore D). When stones are pressed together, the adhesive will ooze out of the joint. On exposed joints, in a textured finish, it is recommended that the excessive adhesive be removed after the adhesive has taken on its initial hardening. The extra adhesive can then be scraped away with a putty knife. Any excessive adhesive on smooth finish is best removed after complete hardening with the use of power sanders.

21. transportation and storage

Extreme care shall be taken to insure that the assembled units are free of any torsional stress during transportation, handling, and storage.

22. erection

A. The stone fabricator shall make provisions for the employment of the necessary lifting methods of the assembled units, in cooperation with the erector. Such lifting devices as clamps, slings, Lewis pins, etc., shall be furnished by the erector.

B. All assembled units of Indiana Limestone shall be erected in strict accordance with the contract and the shop drawings.

V. PERFORMANCE SPECIFICATIONS

The use of a performance specification implies the need for expertise beyond that which typically exists in the office of the designer or specifying authority. In the case of stone cladding, such an expert is an experienced skin-and-connection design engineer. Specifiers should determine, based on preliminary designs, whether such skills are needed. Need will be determined by one or more of the following: knowledge of the performance records of the contemplated systems, materials or connections; complexity of the cladding and/or connection system; unusual or extreme loading conditions; unusual frame or structural configuration.

If it is determined that no such need exists, DO NOT USE THIS SECTION. One of the earlier sections of this specification, describing conventional methods and materials with known or easily predictable performance records, will prove more economical and effective.

If such need is seen to exist, contract documents should make clear who is responsible for providing the engineering services, and the extent of the services expected. Such services may include design of the stone cladding, its thicknesses and its connections, and the supervision of any necessary testing of small-size specimens and scale or full-size mockups. The experience and capacity to produce satisfactory designs and supervision should be assured.

SECTION 04400— STONework

PART 1—GENERAL

1.1 related documents:

Related documents include but are not limited to Drawings, Specifications, and General Provisions of the Contract; ASTM C-568, Standard Specification for Limestone Building Stone; ASTM C-97, Test Methods for Absorption and Bulk Specific Gravity of Building Stones; ASTM C-99, Test Method for Modulus of Rupture of Building Stone; ASTM C-170, Test Method for Compressive Strength of Building Stone; *Indiana Limestone Handbook*, latest edition; *Contractors Handbook on Indiana Limestone*, latest edition; *ILI Technote on Safety Factors*; and other applicable ILI Technotes.

1.2 summary:

1.2.1 Extent of limestone work is indicated on drawings and schedules.

1.2.2 General: Provide Indiana Limestone cladding in accordance with the contract documents. The work shall include the following:

Limestone facade panels.

Limestone preassembled units.

Limestone copings, sills, soffits, lintels, and miscellaneous features.

Steel support and retention connections for stonework, including necessary shims.

Secondary structural steel framing for stonework where not shown or not sized on structural drawings.

Mockups.

Installation of stonework.

1.2.3 Related Work Specified Elsewhere:

Exterior stone paving (sitework).

Unit masonry.

Sealants.

Secondary steel framing for stone support and anchorage as shown and sized on structural drawings.

Interior stone and paving and exterior stone paving.

1.2.4 Installation of preset concrete inserts

1.2.5 Installation of preset masonry inserts

1.3 system description:

1.3.1 General: Design, fabricate, and install stonework to withstand normal loads from wind, gravity, movement of building structure, and thermally induced movement, as well as to resist deterioration under conditions of normal use including exposure to weather, without failure.

1.3.2 Performance Requirements—General: The cladding requirements shown by the general stone details are intended to establish basic dimensions of units or modules, plus profiles and sight lines for the stonework. Within these limitations, the contractor shall be responsible for the design of the stonework, and shall request approval of, and make whatever modifications and additions to the details as may be required to fulfill the performance requirements. The visual concept shall be maintained as shown, including profiles and alignment of components.

The requirements for the stone support and anchorage as shown by the details are intended to establish the basic intent of the stone anchorage system. The contractor shall be responsible for the design of the support and anchorage system and shall request approval of,

and make whatever modifications and additions to the details as may be required to fulfill the performance requirements. Final shapes and locations shall be as designed by a registered professional engineer.

Engineering Calculations: This engineer shall be a registered professional engineer experienced in cladding design to design the cladding support and retention system. The system shall include all items required to connect the stone cladding to the structure (or secondary framing) as shown and detailed on the structural and architectural drawings. The cladding engineer shall be registered in the state of _____ and shall prepare engineering calculations for the justification of all principal stonework, units, fasteners, and anchorage components for compliance with the criteria established in the performance requirements of this section. The calculations shall be submitted to the architect for review and approval. After review, revisions, and final approval, the cladding engineer shall certify a record copy of the calculations with professional engineer's stamp or seal. Based on the design loads, material properties, and safety factors (all as defined in this section), the calculations shall include, as a minimum, the following information:

Stone loads, stresses, and safety factors.

Support and anchorage loads, stresses, safety factors, design loads, and allowable loads.

Stone thicknesses.

Support and anchorage sizes.

Drawings of all support and anchorage items in sufficient detail for fabrication and for the detailing and completion of the shop drawings as prepared by the stone fabricator. The cladding engineer shall review all stone shop drawings prepared by stone installer or fabricator.

1.3.3 Performance Requirements—Stone:

Physical Properties: The Indiana Limestone physical properties shall meet or exceed the values listed in the Indiana Limestone Institute of America, Inc. *Handbook* (ILIA), latest edition.

Safety Factors—Stone: Safety factors for Indiana Limestone shall be not less than as listed in the *Technote on Safety Factors*, as published by ILIA.

Connections and Attachments for Limestone: Support and Retention Steel: All steel shapes, plates and straps shall be designed to carry the design loads with safety factors and allowable stresses in accordance with the American Institute of Steel Construction, Inc. (AISC) except that steel supports carrying gravity loads shall be stressed not more than 50% of the yield stress in bending.

Connections into the Stone: Expansion bolts, straps, hooks, anchors, and other devices shall be designed to carry the design loads with safety factors not less than listed in ILIA *Technote on Safety Factors*.

Attachments to the Structure: Connections and attachments to the structure or secondary framing shall be designed to carry the design loads with safety factors or allowable stresses in accordance with the following:

Welds: Structural Welding Code (AWS D1.1 and AISC).

Expansion Bolts: Per ICBO evaluation report for the specific bolt to be used. If an ICBO report is not available, use not less than the following:

Safety Factors:

Into 4,000 psi concrete—4 to 1

Into grouted CMU—6 to 1

The combined load factor for combined tension and shear shall satisfy the ILIA *Technote on Safety Factors*.

Bolts: AISC.

Concrete Embedded (Cast-in) items: PCI or manufacturer's recommendations, whichever is more conservative. The safety factor shall be not less than 4 to 1 based on concrete failure.

Design Loads: All cladding and cladding attachments shall be designed to carry the following design loads with safety factors not less than specified in this section:

Wind Loads: (Latest Edition) UBC (or applicable code or wind tunnel test results).

Seismic Loads: Per code where applicable.

Vertical Loads:

Dead Loads: Actual computed weight of cladding.

Live Loads: (Latest Edition) UBC (or applicable code).

Provisions for Fabrication and Erection Tolerances: Design, detail and fabricate connections to provide allowance for fabrication tolerances, erection tolerances, and structural deflections.

Concrete structural fabrication and erection tolerances are specified in Division-3 section "Concrete Work."

Structural steel fabrication and erection tolerances are specified in Division-5 section "Structural Steel."

Control of Corrosion: Prevent galvanic and other forms of corrosion by insulating metals and other materials from direct contact with non-compatible materials, or by suitable coating.

1.4 submittals:

1.4.1 Product Data: Submit manufacturer's technical data for all stone, stonework accessories, and other manufactured products required.

1.4.2 Shop Drawings: Submit cutting and setting drawings indicating sizes, dimensions, sections and profiles of stones; arrangement and provisions for jointing, supporting, anchoring, and bonding stonework; and details showing relationship with, attachment to, and reception of, related work. The drawings shall include the details as developed by the cladding engineer as defined in the performance requirements section.

Include large scale details of decorative surfaces and inscriptions.

1.4.3 Samples: Submit the following samples:

Limestone samples in form of sets of three, consisting of stones not less than 12" square. Sample sets will show a range of variations in color and grain to be expected in completed work.

Sealant samples for each type and color of joint sealant required.

1.4.4 Data for Limestone Cladding: For limestone cladding, submit the following data which has been signed and stamped by a qualified professional engineer registered in _____ who thereby

NAME OF STATE

certifies preparing or supervising the preparation of the data to comply with the performance requirements and recognized engineering principles and practices:

Engineering calculations as defined in the performance section.

Connection details as defined in the performance section.

1.5 quality assurance:

1.5.1 Single Source Responsibility for Stone: Obtain limestone from a single quarry source with resources to provide materials of specified consistent quality. The fabricator and the quarry shall have sufficient capacity to quarry, cut, and deliver the stonework on schedule. Both fabricator and quarry must be members in good standing of Indiana Limestone Institute.

1.5.2 Single Source Responsibility for Mortar Materials: Obtain mortar ingredients of uniform quality and from one manufacturer for each cementitious and admixture component and from one source or producer for each aggregate.

1.5.3 Single Source Responsibility for Other Materials: Obtain each type of stone accessory, sealants and other materials from one manufacturer for each product.

1.5.4 Information on Drawings and in Specifications establishes requirements for both aesthetic effects and performance of the limestone cladding. Aesthetic effects are indicated by dimensions, arrangement, alignment and profiles of components and assemblies as they relate to sight lines and relationships to one another and to adjoining work. Performance is indicated by criteria that is subject to verification by either preconstruction or field test, if applicable, or by inservice experience.

Do not modify intended aesthetic effects, as judged solely by architect, except with architect's approval and only to the extent exclusively needed to comply with performance requirements. Where modifications are proposed, submit comprehensive explanatory data to architect for review and approval.

1.5.5 Installer Qualifications: Engage an installer with not less than 10 years experience and who has successfully completed stonework similar in material, design and extent to that indicated for this project. Submit list of completed projects; include project names, addresses, and names of architects and owners.

1.5.6 Preconstruction Tests: Contractor shall obtain material tests as noted below:

Preconstruction Testing Service: Contractor shall employ and pay qualified independent testing laboratories to perform preconstruction testing indicated.

Test limestone for compliance with physical property requirements for Limestone Building Stone, Type II, as listed in ASTM C-568. Conduct tests using specimens randomly selected from, and representative of, actual materials proposed for incorporation in the work.

The following test reports shall be submitted:

ASTM C 99 Modulus of Rupture
ASTM C 170 Compressive Strength

1.5.7 Field-Constructed Mockup: Prepare mockups for the stonework if applicable. Purpose of mockups is further verification of selections made for color and finish under sample submittals and establishing standard of quality for aesthetic effects expected in completed work. Build mockups to comply with following requirements.

Locate mockups on site where indicated or, if not indicated, as directed by architect.

Build mockups containing elements typical of the stonework in this project. The extent of the mockup shall be defined by this section.

Erect mockups only after notifying architect when construction will begin.

Retain mockups during construction as standard for

judging completed stonework. When directed, demolish mockups and remove from site.

Option: Acceptable mockup may be incorporated into the work.

1.5.8 Qualifications for Welding Work: Qualify welding operators in accordance with AWS "Standard Qualification Procedure."

Provide certification that each welder employed in the work is qualified for welding processes involved by having satisfactorily passed AWS qualification tests and, if applicable, by undergoing recertification. Retesting for recertification shall be contractor's responsibility.

1.6 delivery, storage and handling:

1.6.1 Deliver masonry materials to project in undamaged condition.

1.6.2 Store and handle stone and related materials to prevent their deterioration or damage:

Do not use pinch or wrecking bars on stonework.

Lift with wide-belt type slings where possible; do not use wire rope or ropes containing tar or other substances which might cause staining.

Store stone on non-staining wood skids or pallets, covered with non-staining, waterproof membrane. Place and stack skids and stone to distribute weight evenly and to prevent breakage or cracking of stones.

Store cementitious materials off the ground, under cover and in dry location.

1.7 project conditions:

1.7.1 Protect stonework during erection as follows:

Cover top of walls with non-staining waterproof sheeting at end of each day's work. Cover partially completed structures when work is not in progress. Extend cover a minimum of 24" down both sides and hold securely in place.

Prevent staining of stone from mortar, grout, sealants, and other sources. Immediately remove such materials from stone without damage to the stonework.

Protect base of walls from rain-splashed mud and mortar splatter by means of coverings spread on ground and over wall surface.

Protect sills, ledges and projections from droppings of mortar and sealants.

1.7.2 Cold Weather Protection: Comply with the following requirements.

(Part 1.7.2 should be part of the specifications in those projects where mortar is used in setting, and where freezing weather is a possibility.)

Remove ice or snow formed on stonework beds by carefully applying heat until top surface is dry to the touch.

Remove stonework damaged by freezing conditions.

Perform the following construction procedures while stonework is progressing:

Temperature ranges indicated apply to air temperatures existing at time of installations.

In heating mortar materials, maintain mixing temperatures selected within 10 degrees F (6 degrees C); do not heat water for mortar to above 160 degrees F (71 degrees C).

Mortar: At 40 degrees F (4.4 degrees C) and below, produce mortar temperatures between 40 degrees F (4.4 degrees C) and 120 degrees F (49 degrees C) by heating mixing water and, at temperatures of 32 degrees F (0 degrees C) and below, sand as well. Always maintain temperature of mortar on boards above freezing.

At 25 degrees F (-4 degrees C) to 20 degrees F (-7 degrees C), heat both sides of walls under construction using salamanders or other heat sources and use windbreaks or enclosures when wind is in excess of 15 mph.

At 20 degrees F (-7 degrees C) and below, provide enclosure and auxiliary heat to maintain an air temperature of at least 40 degrees F (4.4 degrees C) for 24 hours after setting stonework and heat stones so that they are above 20 degrees F (-7 degrees C) at time of installation.

PART 2—PRODUCTS

2.1 materials, general:

2.1.1 Comply with referenced standards and other requirements indicated applicable to each type of material required.

2.1.2 Provide stone from a single quarry for each grade, color, and finish of stone required.

2.1.3 Make quarried blocks available for inspection by architect.

2.2 limestone:

Limestone Building Stone Standard: ASTM C 568.

2.2.1 Classification: Category II (Medium Density).

2.2.2 Variety: Indiana Limestone.

2.2.3 Finish of Exterior Limestone Cladding: As follows:

Finish Indiana Limestone cladding to match standard finish of Indiana Limestone Institute, Inc. designated below.

(Finish name—insert here)

(OR)

Finish Indiana Limestone to match approved samples and/or mockups of Indiana Limestone.

2.2.4 Furnish Stone in accordance with approved samples and jobsite mockup for type, variety, grade (if applicable), color, and other characteristics relating to aesthetic effects.

2.2.5 Indiana Limestone Grade and Color: Provide color indicated below in accordance with grade and color classification established by Indiana Limestone Institute, Inc. (ILI).

(Quality and color names)

2.3 mortar and grout materials:

2.3.1 Portland Cement: ASTM C 150, Type I except Type III may be used for cold weather construction. Provide gray or white cement as needed to produce mortar color required.

2.3.2 Hydrated Lime: ASTM C 207. Type S.

2.3.3 Aggregate: ASTM C 144; and as indicated below:

For joints narrower than 1/4" use aggregate graded with 100 percent passing the No. 8 sieve and 95 percent the No. 16 sieve.

2.3.4 Water: Clean, non-alkaline and potable.

2.4 stone anchors and attachments:

2.4.1 Provide anchors and attachments of type and size required to support the stonework fabricated from the following metals for conditions indicated below:

Stainless Steel, AISI Type 304 or 316, for anchors and expansion bolts embedded within the stone.

Hot-Dip Galvanized Steel as follows:

Galvanized malleable iron for adjustable inserts embedded in the concrete structure.

For anchor bolts, nuts and washers not in direct contact with stone; comply with ASTM A 307, Grade A, for material and ASTM C 153, Class C, for galvanizing.

For steel plates, shapes and bars not in direct contact with stone; comply with ASTM A 36 for materials and ASTM A 123 for galvanizing.

For expansion bolts not in direct contact with stone use zinc plated or cadmium plated bolts with stainless steel expansion clips.

For steel angles supporting limestone; comply with ASTM A 36 for materials and ASTM A 123 for galvanizing. Supports protected with one shop coat of zinc-rich or other rust-inhibiting paint, and one job coat of similar, compatible paint, may be used at the discretion of the architect.

2.4.2 Dovetail Slots: Where required, furnish dovetail slots, with filler strips, of slot size required to receive anchors provided, fabricated from 0.0336 (22-gage) galvanized sheet steel complying with ASTM A 446, G90.

2.5 preassembled units— Indiana Limestone:

Performance Requirements: Performance requirements defined elsewhere in this section apply to the preassembled units.

2.5.1 Adhesive: The adhesive shall be a two-component epoxy consisting of epoxy resin and hardener.

Adhesive Properties: The adhesive used shall meet the following minimum requirements after a 7-day cure at 75 degrees Fahrenheit.

Property	Value	Test Method
Tensile Bond Strength*	Cohesive failure in stone	ASTM C-321
Tensile Elongation	2.5%	ASTM D-638
Tensile Strength	3,500 psi	ASTM D-638
Compressive Double Shear*	400 psi	MMM G-650A
Compressive Strength	6,000 psi	ASTM D-695
Shore "D" Hardness	75	ASTM D-1706
Water Absorption (24 hours)	0.50%	ASTM D-570

*Note: These tests represent bond strength. Other tests are made on the adhesive only.

2.5.2 Samples: Two sample units of stone bonded together with adhesive shall be submitted showing stone and joint quality. Samples shall be 6" long, 3" wide, 3/4" thick, bonded together on the large face, at

right angles. No fabrication or assembly shall begin until approval of sample is obtained.

Industry practice permits 1/8" thick adhesive joints.

2.5.3 Drawings: The epoxy joint construction including mechanical anchoring and framing shall be shown on the shop drawings.

2.5.4 Shop Assembly Requirements: Stone shall be dry and free from grease, oil, dirt, loose particles, and efflorescence. Clean compressed air should be employed to blow stone dust from the pores of the stone. Heat is recommended for the removal of moisture from the stone prior to applying epoxy. No moisture should be observed creeping into areas to be bonded following the removal of heat.

Units shall not be assembled when the stone temperature and the surrounding air temperatures are below 50 degrees F or above 95 degrees F. Assembly of units below 50 degrees F is permitted when the temperature of the stone units and adhesive is raised by heating to a temperature above 50 degrees F. After the units have been joined, heat should continue to be applied to the stone adjacent to the joint area to give the adhesive the curing temperature above 50 degrees F. Approved clips, frames, expansion bolts, and other mechanical connections shall be installed in strict accordance with approved shop drawings.

Adhesives shall be mixed in parts by weight or parts by volume in strict accordance with manufacturer's instructions, with strict compliance to the manufacturer's recommendations on the "pot life" of the adhesive.

Upon joining the stone members together, suitable clamps or bracing shall be used to keep the stone in proper alignment until the adhesive sufficiently hardens. Process shall include any and all shims needed to insure proper alignment.

Assembled limestone units shall not be moved until the adhesive has cured sufficiently to assure there will be no joint damage. Curing shall continue until the adhesive has reached the required hardness. When stones are pressed together, the adhesive shall flow out of the joint. On exposed joints, in a textured finish, it is recommended that the excessive adhesive be removed after the adhesive has taken on its initial hardening. The extra adhesive may be scraped away with a putty knife. Any excessive adhesive on smooth finish may be removed after complete hardening with the use of power sanders.

All dowels, anchors, expansion bolts, bearing plates, and other steel items in direct contact with the stone or contained within the stone shall be stainless steel AISI Type 304 or 316. Frames, plates, and other steel shapes not in direct contact with the stone shall be ASTM A-36

hot-dipped galvanized after fabrication per ASTM A-123. Bolts not in contact with the stone shall be ASTM A-325 or equal and shall be galvanized or plated with zinc or cadmium.

Fabricate and assemble structural framing in shop to comply with AISC *Specifications for the Design, Fabrication, and Erection of Structural Steel for Buildings*, including “Commentary” and Supplements thereto as issued, and as indicated on final shop drawings.

Weld or bolt connections to comply with the following requirements:

Install high strength threaded fasteners to comply with AISC *Specifications for Structural Joints using ASTM A-325 or A-490 bolts* approved by the Research Council on Riveted and Bolted Structural Joints of the Engineering Foundation (RCRBSJ).

Weld connections to comply with AWS D1.1 *Structural Welding Code—Steel*.

2.5.5 Transportation and Storage: Extreme care shall be taken to insure that the assembled units are free of torsional stress during transportation, handling, and storage.

2.5.6 Erection: The stone fabricator shall make provisions for the employment of the necessary lifting methods of the assembled units, in cooperation with the erector. Such lifting devices as clamps, slings, etc., shall be furnished by the erector.

2.6 stone accessories:

2.6.1 Setting Shims: Lead, stainless steel, or plastic shims, non-staining to stone, sized to suit joint thicknesses and bed depths of stonework involved without intruding into required depths of joint sealants.

2.6.2 Concealed Sheet Metal Flashing: Fabricate from stainless steel or other material complying with requirements specified in Division-7 Section “Flashing and Sheet Metal,” in thicknesses indicated but not less than 0.015” thick.

2.6.3 Plastic Tubing Weeps: Medium density polyethylene, outside diameter of 1/4” and of length required to extend between exterior face of stone and cavity behind.

2.7 elastomeric sealants:

Refer to Section 07900.

2.8 mortar and grout mixes:

2.8.1 General: Do not add mixtures including coloring pigments, air-entraining agents, accelerators, retarders,

water repellent agents, anti-freeze compounds, or calcium chloride, unless otherwise indicated.

2.8.2 Mixing: Combine and thoroughly mix cementitious materials, water and aggregates in a mechanical batch mixer; comply with referenced ASTM standard for mixing time and water content, unless otherwise indicated.

2.8.3 Setting Mortar: Comply with ASTM C 270, Proportion Specification, for types of mortars and applications required below, unless otherwise indicated:

Set Indiana Limestone with Type N mortar.

2.9 stone fabrication:

2.9.1 General: Fabricate stonework in sizes and shapes required to comply with the requirements as shown on approved shop drawings.

2.9.2 Comply with recommendations of the Indiana Limestone Institute of America, Inc. (ILI) as published in the *Indiana Limestone Handbook* (latest edition).

2.9.3 Cut and drill sinkages and holes in stones for anchors, fasteners, supports and lifting devices as indicated or needed to set stonework securely in place; shape beds to fit supports.

2.9.4 Cut stones to produce pieces of thickness, size and shape indicated or required and within fabrication tolerances recommended by ILI.

2.9.5 Thickness of Exterior Stone Cladding:

Provide stone thicknesses required to comply with performance requirements but not less than shown on architectural drawings. Use tables in *Indiana Limestone Handbook* as a guide to size requirements.

2.9.6 Control depth of stones and back-checks to maintain a clearance between backs of stones and surfaces or projections of structural members, fireproofing (if any), backup walls and other work behind stones.

2.9.7 Cut joints (bed and vertical) straight and at 90 degree angle to face, unless otherwise indicated.

2.9.8 Quirk-miter corners, unless otherwise indicated; shall provide for cramp anchorage in top and bottom bed joints of corner pieces.

2.9.9 Cut stones to produce joints of uniform width and in locations indicated.

Joint Width: _____

2.9.10 Contiguous Work: Provide chases, reveals, reglets, openings and similar features as required to accommodate contiguous work.

2.9.11 Fabricate molded work, including washes and drips, to produce stone shapes having a uniform profile throughout their entire length and with precisely formed arrises slightly eased to prevent snipping, and matched at joints between units.

2.9.12 Carve and cut decorative surfaces and inscriptions to conform with shaded drawings or models approved by architect. Use skilled stone carvers experienced in the successful performance of work similar to that indicated.

2.9.13 Finish exposed faces and edges of stones to comply with requirements indicated for finish under each type and application of stone required and to match approved samples and field-constructed mock-ups.

PART 3—EXECUTION

3.1 examination:

3.1.1 Require installer to examine surfaces to receive stonework and conditions under which stonework will be installed and to report in writing any conditions which are not in compliance with requirements. Do not proceed with installation until surfaces and conditions comply with requirements indicated in specifications or elsewhere for execution of other work which affects stonework.

3.2 preparation:

3.2.1 Advise installers of other work about specific requirements relating to placement of inserts, flashing reglets and similar items which will be used by stonework installer for anchoring, supporting and flashing of stonework. Furnish installers of other work with drawings or templates showing locations of these items. General contractor or concrete contractor will provide drawings to locate weld-plates and embeds for connection of stone skin or its system.

3.2.2 Clean stone surfaces which have become dirty or stained prior to setting to remove soil, stains and foreign materials. Clean stones by thoroughly scrubbing stones with fiber brushes followed by a thorough drenching with clear water. Use only mild cleaning compounds that contain no acid, caustic or abrasives.

3.3 setting stone, general:

3.3.1 Execute stonework by skilled mechanics, and employ skilled stone fitters at the site to do necessary field cutting as stones are set.

Use power saws to cut stones; for exposed edges, produce edges which are cut straight and true. Mallet and

chisel cutting will be permitted provided craftsmen are skilled in their use.

3.3.2 Contiguous Work: Provide chases, reveals, reglets, openings and other spaces as indicated for accommodating contiguous work. Close up openings in stonework after other work is in place with stonework which matches that already set.

3.3.3 Set stones to comply with requirements indicated on drawings and final shop drawings. Install anchors, supports, fasteners and other attachments indicated or necessary to secure stonework in place. Shim and adjust anchors, supports and accessories to set stones accurately in locations indicated with uniform joints of widths indicated and with edges and faces aligned according to established relationships and indicated tolerances.

3.3.4 Dampproofing for stain prevention: Where indicated on drawings, coatings of either (a) cementitious waterproof stone backing or (b) bituminous dampproofing shall be applied on backs, beds, and joints of all stones used at grade. Dampproof all adjacent concrete surfaces on which limestone will rest, including concrete or cmu haunches and ledges, as well as support angles.

A. Dampproof unexposed surfaces of stone to at least 1'-0" above grade.

B. Dampproof joints only to within 1" of finished surfaces when using bituminous or asphaltic solutions.

C. Stones extending below grade shall be dampproofed as above, and in addition shall be dampproofed to the level of grade on their face surfaces which are covered.

D. Cementitious coatings must be allowed to cure before treated stone is set. Due care must be exercised in handling all dampproofed stone to avoid chipping or off-setting.

3.3.5 Construction Tolerances: Set stones to comply with the following tolerances:

Variation from Plumb: For lines and surfaces of columns, walls and arrises, do not exceed 1/4" in 10', 3/8" in a story height or 20' maximum, nor 1/2" in 40' or more. For external corners, expansion joints and other conspicuous lines, do not exceed 1/4" in any story or 20' maximum, nor 1/2" in 40' or more.

Variation from Level: For grades indicated for exposed lintels, sills, parapets, horizontal grooves and other conspicuous lines, do not exceed 1/2" in any bay or 20' maximum, nor 3/4" in 40' or more.

Variation of Linear Building Line: For position shown in plan and related portion of columns, walls and partitions, do not exceed 1/2" in any bay or 20' maximum, nor 3/4" in 40' or more.

Variation in Cross-Sectional Dimensions: For columns and thickness of walls from dimensions indicated, do not exceed minus 1/4", nor plus 1/2".

NOTE—The tolerances in this section are masonry industry setting tolerances and are provided for the convenience of the specifier. As a production industry, the Indiana Limestone industry can not and does not control them.

3.3.6 Provide expansion joints, control joints and pressure-relieving joints of widths and at locations indicated or required.

Sealants, expansion, and other joints are specified in Division 7 Section "Joint Sealers."

Use no mortar or shims in expansion joints.

3.4 setting stonework with sealant joints:

3.4.1 Support stonework on gravity supports, and insert anchors for lateral loads, of type and number indicated on final shop drawings, and complying with requirements indicated for material and performance.

3.4.2 Attach anchors securely to stones and to backup surfaces.

3.4.3 Attach framing for stone support system to structural frame of building at connection points indicated by welded or bolted field connections complying with the following requirements:

Install high strength threaded fasteners to comply with AISC *Specifications for Structural Joints using ASTM A 325 or A 490 bolts* approved by the Research Council on Riveted and Bolted Structural Joints of the Engineering Foundation (RCRBSJ).

Weld connections to comply with AWS D1.1 *Structural Welding Code Steel*.

Provide joints to exclude water or permit its escape to exterior of building. Provide weeps at locations where water could accumulate due to condensation or other causes.

For galvanized surfaces of assembled framing, comply with ASTM A 780 for cleaning field welds, bolted connections and abraded areas and application of galvanizing repair paint.

For shop-painted surfaces, clean field welds, bolted connections, and abraded areas, immediately after erection. Apply paint to exposed areas using same material as used for shop painting.

3.4.4 Fill anchor holes with non-staining mortar or sealant.

Where dowel holes occur at pressure-relieving joints, provide compressive material above and below dowels.

3.4.5 For stones supported on clip or continuous angles, set stones on non-corrosive and non-staining shim material in sufficient area to support the load. Mortar may be used in lieu of shims provided that setting pads are provided to maintain joint sizes if stone weight squeezes out mortar.

Place setting buttons of adequate size, in sufficient quantity, and of same thickness as indicated joint width, to prevent mortar from squeezing out and to maintain uniform joint widths. Hold buttons back from face of stone to provide space for backer rope and sealant.

The joint between bottom of relieving angles and top surface of stones below angles shall be free of mortar or shims to avoid load transfer.

3.4.6 Install concealed flashing at continuous shelf angles, lintels, ledges and similar obstructions to the downward flow of water so as to divert such water to the exterior.

3.4.7 Keep cavities open where unfilled space is indicated between back of stone veneer and backup wall; do not fill cavities with mortar or grout.

3.4.8 Place weepholes/vents in joints where moisture may accumulate including base of cavity walls, above shelf angles and flashing. Locate weepholes/vents at intervals not exceeding 2' and those serving as vents only, at intervals not exceeding 5' horizontally and 20' vertically.

3.4.9 Where mortar is used in setting stones on anchors or elsewhere, rake out mortar from joints to depths adequate to receive sealants and sealant backings

3.4.10 Embed ends of lugged sills on shims or mortar; leave balance of joint open until final sealing.

3.4.11 Set the stonework with open vertical joints for installation of joint sealants. Use no shims or spacers in vertical joints.

3.5 installation of joint sealants:

Specified in Section 07900.

3.6 adjusting and cleaning:

3.6.1 Repairing Damaged Stone: Repair of stone is an accepted practice and will be permitted. Some chipping is expected; repair of small chips is not required if it does not detract from the overall appearance of the work, or impair the effectiveness of the mortar or sealant. The criteria for acceptance of chips and repairs

will be per standards and practices of the industry unless other criteria are mutually agreed upon by the limestone supplier and the architect.

3.6.2 Remove and replace stonework of the following description:

Stones so damaged that repair is impossible, either structurally or aesthetically.

Defective joints.

Stones and joints not in conformance with approved samples and field-constructed mockups.

Stonework not complying with other requirements indicated.

3.6.3 Replace in manner which results in stonework conforming to approved samples and field-constructed mockups, complying with other requirements and showing no evidence of replacement.

3.6.4 Clean stonework using clean water and stiff bristle fiber brushes. Do not use wire brushes, acid type cleaning agents, or other materials or methods which could damage stone. Mechanical or pressure cleaning methods may be used if approved by architect. Protect limestone when adjacent brick is being acid-washed.

3.7 protection:

Provide final protection and maintain conditions, in a manner acceptable to fabricator and installer, which ensures stonework being without damage or deterioration at time of substantial completion.

VI. SPECIFICATIONS FOR ASHLAR STONE VENEER AND SAWED STONE TRIM

This section can be used alone when the project requires only coursed or rough ashlar. It should be included with other sections in those projects where such stone use is in addition to cut stone.

1. work included

The work included in this section shall include all labor and material for the furnishing and setting of all interior and exterior Indiana Limestone ashlar veneer and sawed stone trim in accordance with drawings.

2. stone

A. General. Stone shall be (coursed ashlar) (webwall) (drywall)—specify—Indiana Limestone quarried in Lawrence, Monroe, and Owen Counties and produced by a member of the Indiana Limestone Institute.

B. Color. The stone shall be (unselected for color) (all buff) (all gray) (____% buff and ____% gray)—specify.

(use following for coursed ashlar only)

C. Finish. The face surface of the stone shall be (split face) (shot sawed) (chat sawed)—specify.

D. Dimensions.

1. Bed thickness shall be between 3" and 4".
2. Course heights shall be furnished in the following percentages: 15%—2¹/₄"; 40%—5"; 45%—7³/₄". (Specify other percentages and rises.)
3. Stone lengths shall be random, varying between 1'-6" and 4'-0", and shall be jointed at the job to lengths conforming to approved jointing pattern.

(use following for webwall and drywall only)

C. Finish. The face surface of the stone shall be rough broken.

D. Dimensions.

1. (Webwall only) Bed thickness shall be between 2" and 6".
(Drywall only) Bed thickness shall be _____ (specify: between 3" and 4" when used as veneer; random, varying between 4" and 2'-0" when used as full-thick or retaining wall).
2. (Webwall only) Exposed faces shall vary from 1/2 to 3 sq. ft.
(Drywall only) Exposed stone edges shall vary between 2" and 6" high.

E. Sawed stone sills and coping. These items shall be (specify color) Indiana Limestone sawed or otherwise dimensioned to the sizes shown on drawings, and anchored as shown or as detailed in large scale sections.

(following applies to all types)

3. setting stonework

A. Stone shall be set in strict accordance with approved profile and jointing pattern. Joints shall be _____" wide (specify).

B. Stone shall be anchored with non-corrosive wall ties spaced not over 18" horizontally and 24" vertically.

4. mortar

Mortar shall (be as specified for other masonry units) (conform to Type _____ (specify), ASTM C-270 requirements) with final color to be approved by architect.

5. handling and storage

All Indiana Limestone shall be shipped, unloaded and stored in such a manner as to avoid excess breakage and stain. Stone shall be stored at the job on planks, pallets, or timbers, clear of soil and soil splash.

6. cleaning

Finished stonework shall be washed clean and free of dirt, mortar and other objectionable accumulations. Remove mortar droppings and smears as work progresses. Final cleandown shall include brushing with fiber brushes and mild soap or detergent, and rinsing with clear water. Use no acids without prior approval. Protect stonework from rundown or splash when using acid on adjacent materials.

notes on ashlar stone

Coursed or random ashlar is defined as "Semi-Dimensional," having exact course heights and bed thickness, furnished in random lengths for jobsite fitting.

These products are used to best advantage when the variations of grain and natural characteristics are allowed to complement the stone color and jointing pattern.

Sawed or split stone is usually furnished between 3¹/₂" and 4" thick. The individual fabricator will produce only one dimension, but stones from various fabricators will not exceed 4" unless otherwise specified.

Where greater than standard course heights are required, they should be specified as 10¹/₂", 13¹/₄", and 16". These heights will work out well with the standard heights, but the changes in percentages will have to be specified. Standard heights are also available in other percentages, such as 50% 2¹/₄", and should be specified when desired.

When sawed or split ashlar is used in a random pattern, it is suggested that no vertical joint in the pattern be higher than the highest course height being used, no horizontal joint be more than three stones long, and that no two stones the same height be placed end to end.

ILI Technotes

Safety Factors

The following safety factors are intended as general guidelines for determining maximum design loads and stresses in Indiana Limestone, and in anchors and supports for Indiana Limestone. These values represent the minimum safety factors which the Institute considers to be good practice for most applications. The designer must always use judgment based on the specific application to determine proper safety factors. Proper safety factors may be more conservative than the values suggested in this bulletin, depending on the specific condition under consideration.

The physical properties of Indiana Limestone should be determined by lab test for the specific stone to be furnished. In lieu of lab tests, the minimum properties as listed in the Indiana Limestone Handbook, "Performance Tables," may be used to determine maximum allowable working stresses.

Safety Factors

STONE STRESSES

1. Stress Modes—Bending

1.1 Gravity Loads

Stone stressed in bending due to gravity loads: Use not less than 8 to 1 safety factor applied to the modulus of rupture to determine maximum allowable extreme fiber stresses.

1.2 Lateral Loads

Stone stressed in bending due to lateral loads (wind loads or seismic loads): Use not less than 8 to 1 safety factor applied to the modulus of rupture to determine maximum allowable extreme fiber stresses. A stress increase of 1/3 is permissible when the building code for the project permits this increase for other building materials. This provides a safety factor of not less than 6 to 1 for lateral load bending stresses.

1.3 Combined Gravity and Lateral Loads

Combined stone bending stresses due to gravity loads and lateral loads: Use not less than 8 to 1 safety factor applied to the modulus of rupture to determine maximum allowable extreme fiber stresses.

2. Stress Mode

- shear
- compression
- pure tension (axial loads)

Use not less than 8 to 1 safety factor applied to the ultimate test value (at failure) to determine maximum allowable working stresses.

3. Stone Stresses at Connection Points (Anchors)

For connection devices, the maximum allowable design load at the anchorage point of the device into the stone shall not exceed 25% of the failure load of the stone as determined by relevant tests performed on Indiana Limestone.

Anchoring devices subjected to both tension and shear shall be designed in accordance with the following interaction formula:

$$\frac{t}{T} + \frac{s}{S} < 1$$

t = applied tension load

T = allowable tension load

s = applied shear load

S = allowable shear load

The minimum depth of anchor embedment, the minimum center to center distance and the minimum edge distance shall be in accordance with the manufacturers' recommendations (expansion bolts and similar anchors).

It is good practice to install expansion bolts to an embedment depth greater than the recommended minimum depth. This results in substantial increases in the factor of safety with a negligible cost effect.

4. Stone Stresses at Post Tension Anchor Plates

These safety factors apply to stone stresses at post tension anchor plates which have been epoxied to the stone bearing surface to assure complete uniform pressure distribution. Tendon loads shall be precisely applied with specialized equipment by personnel experienced in the proper tensioning procedures.

Stone Compression Stress:

Stone Shear Stress:

Use not less than 6 to 1 safety factor applied to the ultimate test values (at failure) to determine maximum allowable working stresses.

Safety Factors

STEEL STRESSES—CONNECTIONS

5. Stress Mode—Gravity Connections

Maximum allowable bending stresses at gravity supports shall not exceed 50% of the yield stress (18,000 for A36 steel). All other allowable stress to be in accordance with *AISC Manual of Steel Construction*.

6. Stress Mode—Retention Connection (Wind loads and seismic loads)

All allowable stresses to be in accordance with *AISC Manual of Steel Construction*.

7. Stress Mode—Frames for Preassembly of Limestone Panels

All allowable stresses to be in accordance with *AISC Manual of Steel Construction*.

8. Stress Mode—Secondary Framing (Wind girders, braces, hangers)

All allowable stresses to be in accordance with *AISC Manual of Steel Construction*.

9. Stress Mode—Stainless Steel Anchors and Devices Contained within the Stone

Maximum allowable stresses shall be in accordance with *Stainless Steel Stone Anchors* published by the American Iron and Steel Institute (1975), except that the maximum design loads shall not exceed the values defined in Paragraph 3, Stone Stresses at Connection Points (Anchors).

10. Stress Mode—Post Tensioning Tendons and Hardware

Allowable stresses to be in accordance with recommendations of the tensioning materials supplier for the system to be used.

Anchors and Supports

Occasionally the terms “anchor” and “support” are confused or misused. This paper is intended to clarify these terms and their meanings.

The term “support” refers to any material or device which holds or supports stone due to gravity loads. Examples of this condition are concrete haunches at grade or floor slab, metal clip angles, metal plates, or other stones.

The term “anchor” or “tie-back” refers to a (usually) metal item—dowel, strap, disk or other shape, which

holds stone vertical or plumb, and is required to resist only lateral loads or horizontal loads.

Typically, an anchor or tie-back will be embedded in a slot or other sinkage in the stone. Where such embedded condition exists, the anchors in question must be of stainless steel or other noncorrosive material.

A common detail places a rod or blade at the toe of a gravity support (angle or plate) to prevent the stone from slipping or tilting at its base. Such a rod or blade is, actually and technically, a tie-back or anchor, and should be of stainless steel. The angle to which it is attached need not be stainless, but should be protected against rust. (ILI will comment on that procedure to inquirers.)

Among the few exceptions to these rules are the anchors used as gravity supports in soffit design, and the anchors which resist the shear loads associated with coping stones on the raked angle of a gabled roof. These appliances take the shape of anchors, but are so used that they resist gravity loads for these specialized stone applications.

Another example of the use of anchors as supports is the orientation of expansion bolts or other expanding appliances so that they carry gravity loads. (Please note that ILI recommends extreme caution in the use of expansion bolts as gravity supports. Such usage requires careful engineering analysis of the loads, conditions and safety factors required.)

Joint Sealants for Indiana Limestone

As the sealant industry continues to develop new and improved formulae for joint sealants, comments by observers outside that industry become quickly dated. Although ILI updates this Technote from time to time, in consultation with sealant manufacturers, users are urged to review manufacturers' data sheets, and to consult with sales engineers, prior to specifying or approving joint sealant materials for use with Indiana Limestone. ILI personnel are happy to advise on the matter as well.

Indiana Limestone Is a Good Substrate for Most Sealants

Indiana Limestone provides an excellent substrate for adhesion for most sealants in current use. While most materials do not require a primer, many manufacturers recommend their use for best adhesion to limestone.

This is a good point to confirm with the manufacturer, as some will not provide a guarantee unless primers are used. Care should be taken to not apply primers outside the joint area, as some may darken the stone.

Potential Problems with Sealants

Sometimes, the oils contained in sealant formulations cause stain at or under the surfaces of masonry materials. This condition is said to occur in Indiana Limestone with some formulations under some circumstances. In addition, some primers are said to cause stain. Materials which are well-known for their staining potential are oil-based caulks and butyl sealants, though not all butyls stain. ILI suggests oil-based caulks not be used with Indiana Limestone, and that staining tests be run on any butyls under consideration. The general question of stain potential should be part of the decision-making process in choosing joint closing materials. Users and specifiers may wish to pursue this question with manufacturers.

For all sealants, the contact surface of the stone must be dry, clean, dust-free, and frost-free. Some sealant formulations are temperature sensitive. All should be gunned against a backer rod or caulk-stop rope, and the rod or rope must be placed at the proper depth to assure good performance. Of all problems with sealants, failure to observe this rule is by far the most common source of trouble. The sealant bead must meet a ratio of depth-to-width described in the manufacturer's literature; usually that ratio is less than 1:1. Whatever the rule for the sealant being used, it should be followed.

One recurring complaint is the tendency of some formulations to attract dirt. Most manufacturers will have reduced this problem; this is a good question to raise with technical representatives.

Sealants Can Be Used in Mortar Joints

Sealant systems are not necessarily mutually exclusive with mortar systems. In some cases, both mortar and sealant joints are needed on the same project. Or, it may be desirable to face an occasional mortar joint with sealant to match other joints on the job.

The mortar must be raked back to a proper depth, and a sealant tape placed against it. The tape prevents sealant adhesion to the mortar. Sealants tend to fail when gunned against mortar, because they cannot adhere for any length of time to three surfaces. The tape acts as a bond-breaker. Tapes require less rake-depth than rods, and thus leave more mortar in the joint for bearing.

One Part or Two?

The general feeling in the sealant industry is that multi-component job-mixed sealant materials provide higher quality than one-component formulations. As technology improves, it seems likely that one-part sealants will be developed to equal the adherence and long-life qualities of the two-part (job-mixed) sealants. Some types of one-part, high-performance systems now are the equal of two-part systems, their makers claim. Professional sealant applicators are used to the critical measuring and mixing requirements of the two-part sealants; improper measuring and mixing can result in failed joints. One-part sealants tend to be goof-proof, but as a rule they are more expensive than comparable quality, job-mixed formulations. In general, two-part, internal cure systems set and cure more rapidly than one-part, air- or moisture-cure systems. Some sealant types, such as urethanes, are available in both one- and two-part systems. As this issue is so complex, and the technology is ever-changing, ILI suggests that interested inquirers contact sealant manufacturers for the latest information on this subject.

1. Urethanes/Polyurethanes: Tack-free 2-24 hours. Excellent adhesion, with no primer required for most substrates, though often suggested for best long-term adhesion on limestone. 15-20 year life. Good resistance to UV, ozone, and acid atmospheres. Can accommodate movement in the joint up to 50% of design width. Good color selection. -40 to +180 degrees F service temperature range.
2. Acrylic polymeric: Tack-free 1-2 hours after installation, excellent adhesion; 5-10 year life; good for dissimilar materials; -30 to +180 degrees F service temperature range; good resistance to UV, ozone and acid. 10-15% movement capability; primers not required; broad color selection.
3. Silicones: Tack-free time 5-30 minutes; excellent adhesion; 20 year life; service temperature -60 to +300 degrees F; good for dissimilar materials; excellent resistance to attack agents; may require primers; 50% movement capability; broad color selection; may cause staining.
4. Acrylic Latex: Tack-free time 15-30 minutes. Fair adhesion. Fair resistance to UV and ozone. No primers, 12-15% joint movement capability; limited colors; sealant bead accepts paint. Shrinkage and exterior usage ability a consideration in some formulations. 2-10 year life. Often tend to become brittle

with age, though some manufacturers indicate that many formulations do not.

Wood and Steel Stud Construction

ILI does not take an adversarial position regarding the use of steel or wood studs as backup material. Both systems can be made sufficiently stiff to support the lateral loads present in most areas. When ILI is asked to comment on such systems used in conjunction with Indiana Limestone, ILI will make the assumption that the system is sufficiently stiff to resist any lateral loading transferred to it from the stone through its anchoring system.

However, both wood and steel stud systems have potential drawbacks beyond lateral load resistance. These must be considered at the design stage.

Steel stud systems are controversial to some extent. Their connections are typically made with self-tapping screws which hold with only one or two threads, depending on the thickness of the stud material. Wall leaks may allow the entrance of sufficient moisture to attack the screw threads and reduce their strength over short periods. ILI recommends the use of bolts and nuts to attach stone anchors to steel studs and RECOMMENDS AGAINST THE USE OF SELF-TAPPING SCREWS FOR ATTACHMENT OF STONE ANCHORS TO STEEL STUDS.

Wood studs can be expected to shrink. Thus, stiff, brittle materials connected to them may be stressed, and masonry joints may fail. As in the case of steel studs, this condition may not be immediately apparent.

ILI's general rule covering both systems is to approve them as backup materials for Indiana Limestone assuming proper engineering assessment of lateral loads and connections to the studs has been done, and assuming that the weight of the stone in gravity is carried by some other system (as, transferred to grade through stone-on-stone construction).

In short, ILI does not recommend the practice of allowing wood or steel stud systems to carry gravity loads through attachment by supports to stud flanges or edges (as, continuous angles or clips attached to the stud flange and supporting stone in gravity).

ILI will comment on this subject to inquirers.

Indiana Limestone and Acid Rain

The question of polluted atmospheres worldwide has occupied the minds of people interested in the quality of the environment for several hundreds of years. Only within a recent time span has the effect of deleterious airborne materials, or “acid rain,” to use the common and accepted if somewhat inaccurate term, concerned architects, builders and their clients.

We need look only at newly cleaned masonry buildings in such cities as London and Paris to see the results of centuries of discoloration by wood and coal fires. Walls blackened with crusts, in some cases inches thick, were revealed in original colors seen for the first time in living memory.

This condition, that of accumulated dirt and scale, proved in the case of some materials to be a cover under which degradation had proceeded unobserved. Scholarly treatises on the subject offered case histories of twelfth- and thirteenth-century cathedral statuary where features had been completely eroded, apparently within the last three to four decades. The architectural press published graphic evidence of deterioration in all manner of materials, in every kind of environment. Paints appeared to be particularly delicate; aluminum, especially mill-finished, became pitted and corroded. Anodized finishes too seemed to show streaking and pitting. Coatings on glass flaked and bubbled.

Some masonry materials appeared to fare better than others in the same atmospheres. Certain classes of stone, predicted by common knowledge to be immune to attack, showed severe deterioration. While some carbonate rocks exhibited great degradation, others

showed little if any change. Some quartz and feldspar rocks escaped damage entirely; others crumbled.

The broadest of generalizations, based on reports from Europe, formed the basis of materials usage recommendations here in the Western Hemisphere, and claims and counterclaims about weather-resistant properties in materials became as important as aesthetics. Important voices were heard to question the very existence of pollution.

Still, in the New England states, *something* was causing massive fish-kills. Tree-covered mountains were denuded. Acrimonious political exchanges flew across the border between the U.S. and Canada. Coal-burning generating plants installed massively expensive scrubbers to remove sulphurous fumes from their stacks. U.S. car makers, after long and angry debate, installed expensive catalytic converters in the exhaust systems of their automobiles to reduce sulphurous emissions.

The smoke began, both literally and metaphorically, to clear. Air quality *did* improve notably in places, and it became obvious that the dramatic conclusions reached by groups and spokesmen on both sides of the question were far less dramatic than had been originally imagined, or were, simply, wrong.

As concern for integrity in construction materials increased, Indiana Limestone Institute (ILI) and its member companies began an intensive study of limestone performance. That effort, involving both visual inspection and physical testing of Indiana Limestone recovered from older buildings, is the subject of the following technote.

Durability and Weathering in Contemporary Atmospheres

Acid Rain in Vermont

During October, 1986, ILI personnel with disinterested observers examined Indiana Limestone buildings of various ages in Vermont, one of the New England states worst hit by acid precipitation. The object was to determine the extent of damage to the stone. The results of that trip are expressed in this excerpt from a report to the U.S. Department of the Interior by Indiana State

Geologist Emeritus, Dr. John B. Patton: “. . . acid precipitation or acid atmosphere, despite whatever damage to [flora and fauna] is attributable to it, does not seem to have affected the limestone . . . notably or measurably within the last several decades . . . We saw . . . structures dating from the first quarter of the 19th century that still had most of their original mortar in place, even though it was burned lime at that time, rather than portland [cement] mortar. Tool marks were still clear in the form of drafted margins and scabbling, and arrises were crisp. . . . I am not suggesting that acid rain . . . is to be taken lightly, but I doubt that it is a major factor in the durability of stone.”

The Soldiers and Sailors Monument in Indianapolis

These comments are supported by the appearance of stones from the several Vermont buildings pictured below. Shown also are details of the Soldiers and Sailors Monument, in Indianapolis, completed in 1902. In the years since its completion, it has been cleaned three times, once by unknown methods, once by sand-

blast, and most recently by a proprietary acid-based chemical. Sand-blasting and acidic chemicals are known to roughen surfaces of calcareous stones. Even so, and after nearly ninety years of exposure, the surface features of carvings on that monument are still nearly as crisp as they were originally. In protected areas, where little cleaning was necessary, original tool marks are sharp. Tool marks are still evident on most corners of the monument's shaft.



1.



2.

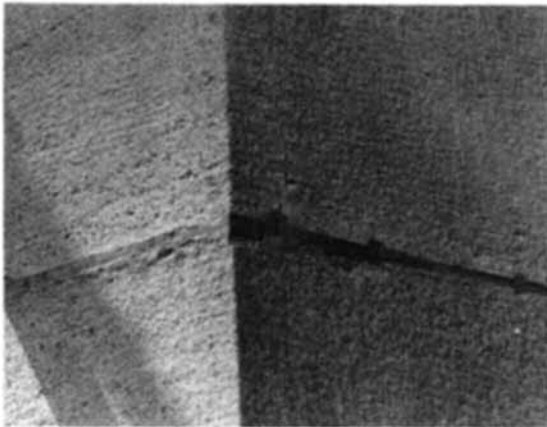

3.

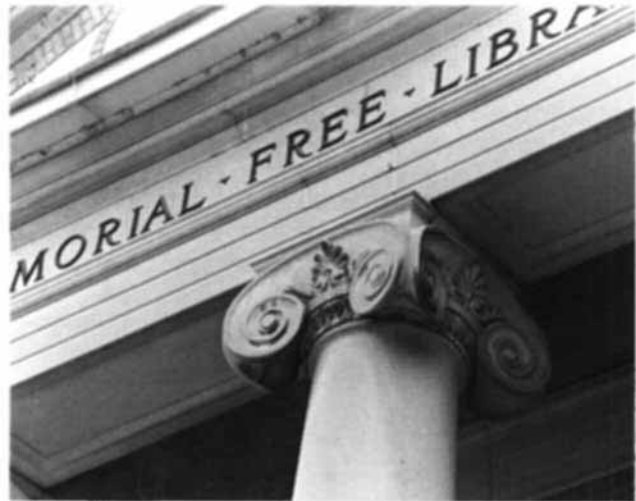

4.

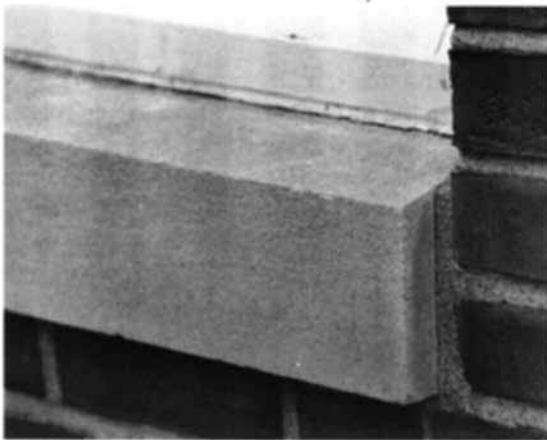

5.

1. One of eight large eagle carvings at the 200 foot level, Soldiers and Sailors Monument, Indianapolis, in place since 1900. This bird has lost one talon in 90 years.
2. Detail of carving, showing original details still crisp.
3. Detail of shaft corner at 100 foot level, showing drafted margin still clear after 90 years.
4. Detail of column capital, Memorial Free Library, Vergennes, VT, ca. 1925. Ornament still sharp and clear.
5. Waist-level sill, athletic field ticket booth, Norwich College, Northfield, VT, ca. 1940. No evidence of chemical attack.

The Illinois State Capitol

In August of 1988, ILI obtained specimens of Indiana Limestone which were salvaged from the Illinois State Capitol in Springfield, where they had been placed just below the dome, exactly 100 years earlier.

The thickness of the stones was such that weathered, 2¹/₄" thick specimens could be sliced off their top surfaces, exposing an unweathered layer which was sliced off, also 2¹/₄" thick. The two layers, weathered and unweathered, were tested for modulus of rupture (bending), compression, and abrasion. Results of that test series, encompassing 36 specimens, showed that the *weathered* stone had *gained* strength as compared to the unweathered stone.

These results are the exact opposite of those predicted by conventional wisdom. They seem to confirm the opinion long held by stone producers, that Indiana Limestone weathers by developing a "skin" which is significantly harder and more durable than unweathered stone surfaces. Note that all strength data quoted by ILI is based on freshly quarried specimens. Details of the Illinois State Capitol test series are available on request.

The National Acid Precipitation Assessment Program (NAPAP)

During the period of these investigations, an experiment by the U.S. Government was under way. Common building materials were chosen to determine their susceptibility to acidic atmospheres. Indiana Limestone was chosen for the study as one of these standard materials. Specimens collected from Indiana quarries in 1983 were placed in exposure panels in five locations around the U.S.

During its annual assessment in 1987, the NAPAP Executive Summary, in its section titled Effects on Materials, stated that "Measurements of carbonate dissolution based on gravimetric mass loss, surface recession and calcium measured in runoff solutions yield consistent estimates of minimum stone damage."

The Test Wall at National Bureau of Standards

In 1948, ASTM Committee C-18 cooperated with the National Bureau of Standards in the construction of a test wall, using stone specimens donated by the National Museum. The stones had been collected by the Museum over the previous 60 years. When the Bureau moved from its original location on Wisconsin Avenue in Washington, D.C. to Gaithersburg, MD, it arranged to move the wall as well.

The wall is 40 feet long and 12 feet high. It contains more than 2,000 stone specimens from all over the world. Seventeen of those specimens are Indiana Limestone. (Interestingly, nine of that number were obtained from working quarries when the wall was constructed, to be used as coping stones, because of the acknowledged durability of Indiana Limestone.)

In the years since the wall's erection, many of the stone specimens have begun to show wear; severe deterioration is obvious in some.

But on the Indiana Limestone specimens, sharp arrises and corners are still apparent. Not a single Indiana Limestone specimen shows weathering distress other than minor surface fretting.

Finally . . .

ILI takes no position on the major questions being discussed at seminars and symposia across the country regarding acid rain, its causes and its cures. Our official interest in the problem is limited to a single question: How does Indiana Limestone perform in polluted atmospheres? Cited here are test results, experiments, comments from knowledgeable observers, and evidence of long-term durability, all supporting the conclusion that Indiana Limestone coexists satisfactorily with pollution. Stated another way, if humans can live in a given environment, they will be pleased with the performance of Indiana Limestone there.

Indiana Limestone's performance record is, for practical purposes, unique among construction materials. Poor performance by other stones has caused concern for the durability of stones in general; indeed, accelerated weathering test programs may be necessary for untried materials. Many such programs are widely promoted; they tend to be costly and time-consuming.

When ILI procedures are followed, Indiana Limestone's performance record makes such programs redundant.

ILI recommends including the following paragraph in specifications where major testing programs are required:

Stones which have a satisfactory performance record in thicknesses, sizes and climates similar to those for this project may at the option of the architect be exempted from the specified testing requirements. The contractor may submit evidence as to such past performance and/or test results for the architect's review. The architect shall have sole authority to approve materials without further testing, or to modify test procedures required for approval.

Among ILI publications is *The Indiana Limestone Specification Guide*. It contains suggested standard and per-

formance specifications for all Indiana Limestone products. Designers and specifiers will be interested in ILI publications such as the *Indiana Limestone Handbook*, *How to Avoid Small Area Stains and Blemishes*, *The Finishing Touch*, and our various Technotes. A publication list is free on request.

Grouted Cavity Walls

The original philosophy of grouting walls developed as architecture moved away from bearing wall toward curtain wall design. It incorrectly assumed that a thin wall, lightly loaded, would act similarly to a heavily loaded thick one.

ILI believes that the structural capacity of grouted walls which are otherwise unreinforced is not well understood and that the only purpose served by grouting cavities is to stiffen the wall. Grouting causes the inner and outer wall to act in concert. Cavity wall construction assumes that the outer wall and the backup will move differently, at least between columns and floors, or within an area defined by relief angles and control joints.

Differential movement aside, grouted cavity walls cannot handle internal moisture nearly as well as standard cavity construction. Further, if the cavity is grouted full, and the stone is not dampproofed, the probability of the occurrence of alkali stain is greatly increased.

Unless there is a clearly understood engineering reason for grouting a cavity wall such as a seismic requirement or other structural considerations, the ILI does not recommend this practice. In cases where it is determined that grouting must occur, dampproofing must be applied.

ILI will, upon request, comment further on this subject.



Recommended Indiana Limestone Wall Heights

In the past, building designs utilized bearing wall construction where large stones were installed one course at a time from grade to considerable elevations. In contrast, modern construction designs utilize relatively thin stone veneer and a variety of back-up materials from CMU to stud systems. A question often posed is how high can limestone panels be safely stacked without relieving angles.¹

Compressive strength of the stone is one factor in answering this question. The minimum compressive strength of Indiana Limestone is 4000 psi. The minimum safety factor recommended by the Indiana Limestone Institute for bearing stress is 8 to 1. Allowable compressive stress is therefore 500 psi. If perfectly uniform full bearing were achieved at the bottom bed—where load is the highest—Indiana Limestone could theoretically be stacked about 500 feet high with ideal conditions. But several other factors must be considered, each of which limits this theoretical height. A partial list follows:

1. Local building codes must always be consulted and they may mandate maximum stack heights.
2. The back-up structure must have been designed and constructed to comprehend, accommodate and permit the intended stacking height.
3. Even if full mortar beds are specified, truly uniform bearing is seldom achieved.
4. Setting buttons used with mortar beds should be relatively compressible so the buttons will deform thereby transferring load to the mortar bed. Also, setting beds are rarely perfectly flat or parallel, and the selection of bearing pads must accommodate the likelihood of high spots.
5. Anchors in bedding joints should be designed and installed to avoid point loading.
6. Ledges, shelf angles and bearing pads must be sized to provide adequate bearing.
7. Designs must accommodate differential volume changes where materials other than limestone support or abut stone.
8. Relief joints in the back-up structure should be matched with those in the cladding.
9. Out-of-plumb conditions or vertical offsets can result in concentration of stress along panel edges.
10. The higher the stack, the more relative movement there will likely be between the cladding and the

back-up. Accommodation of this greater relative movement requires more complex anchors.

11. Deflection, or “drift,” of the back-up structure at full design load may limit stacking heights, especially when considering corners and returns. Special joint patterns and larger joint sizes may be required.
12. Allowable stack heights may be affected by lateral seismic design loads.
13. As stone is stacked higher, the margin of tolerance for even minor errors in either design or installation drops significantly.

ILI’s general rule is to recommend the weight of the stone be carried at each floor level. Relieving angles must be adequately supported by the back-up structure, and joints must be sized to accommodate actual deflection and sealant capabilities and performance.

If there are no intervening floors and assuming that bearing is adequate, that the anchoring systems have been designed and installed properly, and that the back-up structure has been appropriately designed to permit these heights, ILI offers the following maximum wall heights between gravity supports as conservative guidelines:

- for 4 inch limestone – 25 to 30 feet**
- for 3 inch limestone – 20 to 25 feet**
- for 2 inch limestone – 15 to 20 feet**

ILI recommends that limestone panels not be less than 2 inches thick. In all cases, regardless of how high they are to be stacked, stone panels must be sized and properly anchored to the back-up to handle wind loads, seismic loads, and other required design factors. This will sometimes require design by an experienced cladding designer. The back-up must also be properly designed to receive these loads, to permit the stacking height and for attachment of the stone anchors.

There will be instances, dictated by the situation, where stone may be safely stacked higher or should be stacked lower than indicated in these general rules. In all cases, the stone and its support and anchorage system should be properly evaluated to assure a proper and safe design.

For most installations, compressive stress or shear stress at the beds will control. But for tall stacks of thin stone, column buckling may control. Very little research or empirical data is available for this condition and ILI recommends avoiding tall stacks of thin stone.

Additional information about the use and installation of Indiana Limestone may be found in other ILI publications.

¹A relieving angle is defined here as an angle designed and installed to carry the weight of the cladding material above. It has a soft relief joint below of sufficient width to assure there is no load transfer to the cladding material below. Typically a relief joint is caulked.

ILI Technote On Hand Rails And Posts

The Indiana Limestone Institute believes it is generally best to avoid attaching hand-rail posts (or similar features) to stone copings, caps, steps or cornices. In part, this is because the design loads for hand rails required by most building codes mean these posts can impose very significant loads and stresses at the attachment points. Also, in some cases the method of attachment itself can cause distress in the stone.

ILI suggests that, as a general rule, hand rail posts should pass through and be isolated from the stone and be anchored directly to an adequate underlying structure. (The hand rail supplier should also be consulted for appropriate anchoring methods and other hand rail design considerations). These pass-through joints should have adequate clearance and be properly sealed with a flexible and weather-resistant material so as to isolate the stone from any load or movement that might be transferred from the hand rail posts. One possible method for isolating the post from the stone is shown in Figure a.

Post locations should be coordinated with stone jointing whenever possible, both for appearance and ease of installation. This concept is shown in Figures b and c.

If hand rails or hand-rail posts must be attached directly to the stone, the stone and its anchors and supports must be evaluated for the proposed method of attachment and for the loads that will be applied. Note that the use of expansive grout or expansion-type or corrosive anchors will induce stress in the stone. This stress could be high enough to cause the failure of the stone, particularly if edge distances are not adequate. For this reason, ILI generally discourages the use of expansive anchors for this and other applications and advises against the use of expansive grouts for any Indiana Limestone application.

In all cases corrosion of, or run-off from, the railing system or its posts may cause staining of the stone. ILI recommends that non-corrosive or non-staining materials be used for railing systems and components located at or near Indiana Limestone.

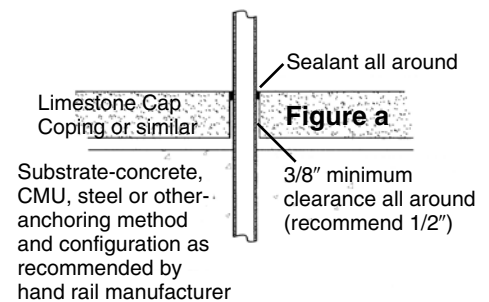
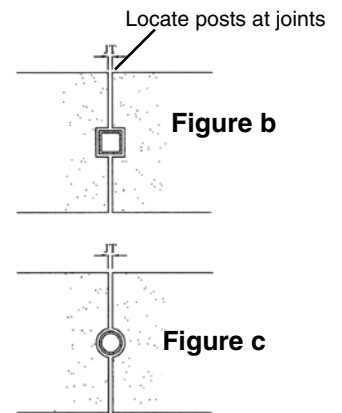

Typical Hand Rail Post Detail

glossary

- ANCHOR**—A metal tie used to secure stone in place.
- ARCHITRAVE**—The member of an entablature resting on the capitals of columns and supporting the frieze.
- ARRIS**—The angle, corner, or edge produced by the meeting of two surfaces.
- ASHLAR**—A flat faced surface generally square or rectangular having sawed or dressed beds and joints.
Coursed Ashlar—Ashlar set to form continuous horizontal joints.
Stacked Ashlar—Ashlar set to form continuous vertical joints.
Random Ashlar—Ashlar set with stones of varying length and height so that neither vertical nor horizontal joints are continuous.
- BALUSTER**—A miniature column or other form of upright which, in series, supports a handrail, as in a balustrade.
- BALUSTRADE**—A railing or parapet consisting of a handrail and balusters, sometimes on a base member and sometimes interrupted by piers.
- BED JOINT**—A horizontal joint between stones, usually filled with mortar, lead, or sealant.
- BELT COURSE**—A continuous horizontal course, marking a division in the wall plane.
- BEVEL**—The angle that one surface or line makes with another, when they are not at right angles.
- BOND STONE**—Stones projecting laterally into the backup wall used to tie the wall together.
- BUGGED FINISH**—A smooth finish produced by grinding with power sanders.
- BULL NOSE**—Convex rounding of a member, such as the front edge of a stair tread or window sill.
- CALCITE STREAKS**—Description of a white or milky streak occurring in stone. It is a joint plane usually wider than a glass seam which has been recemented by deposition of calcite in the crack. It is structurally sound.
- CAPITAL**—Column cap.
- CARVING**—Cutting of ornamental shapes, figures, etc. from models or details, which are too intricate to produce from patterns.
- CHAT SAWED**—Description of a textured stone finish, obtained by using chat sand in the gang sawing process.
- CORNICE**—A molded projecting stone at the top of an entablature.
- COURSE**—A continuous horizontal band of stone of constant height.
- CROWFOOT**—(Stylolite) A dark gray to black zig-zag marking occurring in stone. Usually structurally sound.
- CUT STONE**—Finished, dimensioned stone, ready to set in place.
- CUTTING**—Handwork required to finish a stone which cannot be done by machine.
- DAMP PROOFING**—One or more coatings of a compound that is impervious to water. Usually applied to the back of stone or face of back of wall.
- DENTIL**—Block projections on an entablature.
- DENTIL COURSE**—Mold course immediately below the cornice, having on one of its members, small uniformly spaced blocks, referred to as dentils.
- DIAMOND SAWED**—Finish produced by sawing with diamond toothed saws (either circular or gang).
- DIMENSIONED STONE**—Stone precut and shaped to specified sizes.
- DRIP**—A slot cut in the bottom of a projected stone, to interrupt the capillary attraction of rain water.
- DRY SEAM**—Unhealed fracture which is a plane of weakness.
- EFFLORESCENCE**—The formation of a white saline powder on the surface of masonry walls.
- ENTABLATURE**—Consists of an architrave, frieze, and cornice.
- ENTASIS**—The curve resulting from the gradual diminishing of the diameter of the upper two-thirds of a column.
- EPOXY RESIN**—A flexible usually thermal setting resin made by polymerization of an epoxide and used as an adhesive.
- EXPANSION ANCHOR**—A metal expandable unit inserted into a drilled hole that grips stone by expansion.
- FRIEZE**—Flat member of the entablature occurring above the architrave and below the cornice.
- GANG SAW**—A machine with multiple blades used to saw rough quarry blocks into slabs.
- GLASS SEAM**—Vein fillings of coarsely crystalline calcite, that do not necessarily decrease the strength of stone.
- GROUT**—Mortar of pouring consistency.
- HIGH-STRENGTH ADHESIVE**—A bonding agent of high ultimate strength used to join individual pieces of stone into preassembled units.
- INCISE**—To cut inwardly or engrave—as in an inscription.
- INSCRIPTION**—Lettering cut in stone.
- JOINT**—The space between stone units—usually filled with mortar, joint sealant, or epoxy.
- KEystone**—The wedge-shaped stone placed at the top center of an arch.
- LEWIS BOLT**—A tapered head wedged in a tapered recess in stone for hanging soffit stones.
Box Lewis—A tapered metal box wedged in the top of columns or other heavy stones for hoisting.
Lewis Holes—Sinkages in the top beds of stone to engage Lewis pins for hoisting.

- MASONRY**—That branch of construction dealing with plaster, concrete construction, and the laying up of stone, brick, tile and other such units with mortar.
- MITER**—The junction of two units at an angle. The junction line usually bisects on a 45 degree angle.
- MOLDINGS**—Decorative stone deviating from a plane surface by projections, curved profiles, recesses or any combination thereof.
- MORTAR**—A plastic mixture of cement, lime, sand, and water used to bond masonry units.
- NATURAL BED**—The horizontal stratification of stone as it was formed in the deposit.
- POINTING**—The final filling and finishing of mortar joints that have been raked out.
- PREASSEMBLED UNITS**—Two or more stones combined into a single unit by the use of epoxy resins, steel framing or concrete backing.
- QUARRY**—The location of an operation where a natural deposit of stone is removed from the ground.
- QUOINS**—Stones at the corners of a wall emphasized by size, projection, rustication, or by a different finish.
- RECESS**—A sinkage.
- REGLET**—A recess to receive and secure metal flashing.
- RELIEF or RELIEVE**—Projection of ornamentation.
- REPRISE**—Inside corner of a stone member with a profile other than a flat plane.
- RETURN or RETURN HEAD**—Stone facing with the finish appearing on both the face and the edge of the same stone—as on the corner of a building.
- REVEAL**—The exposed portion of a stone between its outer face and a window or door set in an opening.
- RUSTICATION**—A recessed surface cut around or across the face of a stone to produce shadow accent.
- SCOTIA**—A concave molding.
- SCULPTURE**—The work of a sculptor in three-dimensional form by cutting from a solid block of stone.
- SEALANT**—A resilient compound used as the final weather face in stone joints. (This term is sometimes misused to indicate clear water-repellent treatments which are sometimes sprayed or otherwise applied to masonry.)
- SHOT SAWED**—Description of a finish obtained by using steel shot in the gang sawing process to produce random markings for a rough surface texture.
- SLAB**—A slice of stone cut from a large quarry block.
- SLIP JOINT**—A connection which permits vertical or horizontal movement of the cladding with respect to the structural frame.
- SMOOTH FINISH**—A finish of minimum textural quality, presenting the least interruption of surface. Smooth finish may be applied to any surface, flat or molded. It is produced by a variety of machines.
- SOFFIT**—The finished underside of a lintel, arch, or portico.
- SPANDREL**—The stone panel between the window sill and the window head below it.
- SPLAY**—A beveled or slanted surface.
- STATUE**—A sculpture of a human or animal figure.
- SURROUND**—An enframingent.
- SUPPORT**—An angle, plate or other stone which carries a gravity load.
- TEMPLATE**—A pattern used in the fabrication operation.
- TEXTURE**—Any finish other than a smooth finish.
- THROAT**—The under-cut of a projected molding to form a drip.
- TOLERANCE**—Acceptable dimensional allowance, under or over ideal net sizes.
- TRACERY**—A curving mullion of a stone window, as in Gothic architecture.
- TRIM**—Stone used as sills, copings, enframingents, etc., with the facing of another material.
- UNDERCUT**—Cut or molded so as to present an overhanging part, as a drip mold.
- VENEER**—A layer of facing material used to cover a wall.
- WALLS, BEARING**—A wall supporting a vertical load in addition to its own weight.
- WALLS, CAVITY**—A wall in which the inner and outer wyths are separated by an air space, but tied together with metal ties.
- WALLS, COMPOSITE**—A wall in which the facing and backing materials are bonded together.
- WATERPROOFING**—See Dampproofing.
- WATER REPELLENT**—Any of several types of clear liquids used to render masonry walls less absorptive. These treatments are said to maintain a material's ability to breathe away moisture, as distinct from "sealers" which form impervious, non-breathing coatings.
- WEEPHOLE**—A drainage opening usually inserted at the base of a stone unit to release moisture accumulating between the stone and backup.
- WIND (wined)**—A warp in a semi-finished stone slab—to be removed by further fabrication.
- WYTH**—The inner or outer part of a cavity wall.

index

See Also: Various Case Histories
pp. 114-124
Glossary, pp. 152-153

Adhesives (See Also Preassemblies)	132
Anchoring—	
Stone to Steel Frame	58, 59
Stone to Concrete Frame	60
Stone to Masonry	55, 57, 59-62
Ashlar Stone Veneer	80-83
To Existing Buildings	57
Anchors—	
Standard Practice	17-19
Details—Miscellaneous	17-19, 21
Architrave	67, 76
Arch Theory & Practice	38
Ashlar	80-83, 142
Baluster	77
Balustrade	77
Base Course	53, 83
Bed, Natural	7
Belt Course	82, 83
Bond Stone	82
Box Lewis	44
Brick and Block Chart	46
Canopies and Soffits	68
Capital	73-76
Carving	34, 126
Case Histories	84-124
Charts, Graphs and Tables	
Anchor Guide	19
Angle/Plate Supports	20
Chemical Analysis	6
Classifications	10
Coursing Chart	46
Deposit Location	6
Fabrication Tolerances	35-36
Lintel Table	37
Metric Equivalents	45
Panel Sizes	15
Performance Tables	7-10
Physical Properties	7
Production Diagram	49
Sound Transmission	9, 10
Stratigraphic Section	5
Thermal Properties	8-9
Wind Load	16-18
Chemical Analysis	6
Classification of Indiana Limestone	10
Cleaning	38-40, 141
Cold Weather Setting	24
Colors of Indiana Limestone	10
Columns	73-76
Construction Criteria	13-15
Control Joints	27
Coping	69, 82
Cornice	67, 73-76
Cost Factors	48
Coursing Chart	46
Dampproofing (See also Water Repellent Treatment)	30-31, 83
Definitions	152
Dentil Course	75, 76
Design Criteria	13-15
Design Factors—See Charts, Graphs and Tables	
Door Trim	65, 66
Dowel Pins	19, 53, 68
Drips	13, 69
Efflorescence	11
Engineering Data—See Charts, Graphs and Tables	
Entablature	73-76
Epoxy (See also Preassemblies)	42, 61, 70, 132
Expansion Anchors	19, 121-123
Expansion Joints	27-29
False Joints	30
Finishes—Description and Adaptability	36, 48-49
Flashing	33
Flooring and Paving	32
Floor-to-floor Panel Construction	54
Freestanding Stones	17
Frieze	73-76
Geology of Indiana Limestone	5
Glossary	152
Grades and Grading	
Classifications of Indiana Limestone	10
Using the System	50
Grid Systems	55
Handling	43-44
History of the Industry	4
Inscriptions	34
Joint Sealant Design (See also Mortars: Pointing)	25
Lewis Pins	44
Liner Block Assemblies	61
Lintel Table	37
Maintenance	39-42
Masonry Heights Chart	46
Metalwork	33
Metric Equivalents	45
Mortar	22-24, 127
Natural Bed	7
Panel Sizes	15-17
Panels—Details	53-61, 70-72, 114-115, 119-124
Parapet Walls	18, 82
Patching	41, 42, 126
Physical Properties and Performance Characteristics	7-10
Platforms	63
Pointing	23
Portico	76
Post Tensioning	56, 118
Preassemblies	56, 70-72, 119-123
Pressure Relieving Joints	29
Product Description	6
Production Diagram	49
Quoins	83
Radial Stone	15
Random Ashlar	80-83
Reglets	33
Rock Face	50-52
Rose Window	79
Sawed Finishes	36
Sculpture	34, 126
Sealants	25, 129
Seismic Considerations	42
Seasoned Stone	7
Sills	64-65, 82
Slip Joint	21, 54
Soffits	68
Sound Transmission	9
Specifications	125-143
Split Face	80-83
Staining	7, 11, 30-32
Standards and Practices	13-15
Steel Lintels	38
Steel Studs	25-27
Steps and Platforms	63
Storage	43-44
Sun Screen	115
Support Systems and Tables	20, 21, 37
Thermal Properties	8-9
Tolerances	35-36
Tracery	78-79
Traditional Details	66, 67, 73-79
Trim	82-83
Veneer	80-83
Water Repellent Treatment (See also Dampproofing)	31
Watertables	83
Weeps, Wicks	34
Wind Loading	16-18
Window Trim	64-65, 82
Wood Studs	25-27



INDIANA LIMESTONE
INSTITUTE OF AMERICA, INC.
Suite 400
Stone City Bank Building
Bedford, Indiana 47421
(812) 275-4426